

<b>TO:</b>	<b>CHAIR AND MEMBERS COMMUNITY AND PROTECTIVE SERVICES COMMITTEE MEETING ON AUGUST 28, 2017</b>
<b>FROM:</b>	<b>KATE GRAHAM DIRECTOR, COMMUNITY AND ECONOMIC INNOVATION</b>
<b>SUBJECT:</b>	<b>LAV III MONUMENT AGREEMENTS</b>

<b>RECOMMENDATIONS</b>
------------------------

That, on the recommendation of the Director, Community and Economic Innovation, the following actions **BE TAKEN** with respect to the execution of agreements related to the purchase and location of a LAV III Public Art Monument:

- a) the by-law attached hereto as Appendix "A", **BE INTRODUCED** at the Municipal Council meeting to be held on September 5, 2017:
  - (i) to approve the Canada Company LAV III Agreement between the Corporation of the City of London and Canada Company to purchase a LAV III Public Art Monument; and,
  - (ii) to authorize the Mayor and Clerk to sign the Agreement, attached as Schedule A to the by-law.
  
- b) the by-law attached hereto as Appendix "B", **BE INTRODUCED** at the Municipal Council meeting to be held on September 5, 2017:
  - (i) to approve the Department of National Defense (DND) Licensing Agreement between the Corporation of the City of London and DND for placement of the LAV III Public Art Monument at Wolseley Barracks (The Royal Canadian Regiment Museum (RCR) outdoor display area) on a permanent basis; and,
  - (ii) to authorize the Mayor and Clerk to sign the Agreement, attached as Schedule A to the by-law.

<b>PREVIOUS REPORTS PERTINENT TO THIS MATTER</b>
--

- City Council, November 19, 2007 – Adoption of Public Art Policy
- Board of Control, January 14, 2009 – Creation of Public Art Program Acquisition And Maintenance Reserve Funds
- Community and Protective Services, March 30, 2016 – Direction to apply for a LAV III Public Art Monument

<b>BACKGROUND</b>
-------------------

The City of London continues to seek opportunities to honour the many veterans from the London community. There have been several recognitions this year, associated with Canada's sesquicentennial and the anniversary of Vimy Ridge, and investments continue to be made in lasting commemorative infrastructure in an effort to ensure that the sacrifice made by London's veterans is never forgotten.

In April 2016, Council directed Administration to submit a joint application with the Royal Canadian Regiment (RCR) Museum to the Canada Company's LAV III Monument Program. The Canada Company is a non-profit agency which honours veterans. The LAV III Monument Program was established to recognize the service of the Canadian Armed Forces by providing 250 de-militarized replica light-armored vehicles (LAV) to communities across Canada, in recognition of the more than 40,000 soldiers who served Canadian peacekeeping missions including the conflict in Afghanistan.

The London community has significant connections to the LAV III Monument Program. The LAV IIIs used by the Canadian Army are built by General Dynamics Land Systems (GDLS) in London. To turn the LAV IIIs into monuments, the turrets and hulls have been welded at Militex Coatings, in London, by welding students from Fanshawe College. London is also considered a defense industry hub, with more than 12,000 people employed in the sector at more than 45 defense related London companies. Most significantly, London mourned a personal loss when Trooper Mark Andrew Wilson was killed at the age of 39 by an improvised explosive device in Afghanistan in October 2006. As a result of these London connections, the first of the 250 LAV III monuments was held in reserve to be located in the London community.

With Council direction, the City of London and the RCR Museum submitted a formal application to obtain a LAV III monument in April 2016. The application identified Wolseley Barracks in the RCR Museum outdoor display area as the location for the monument. The application was pre-approved in May 2016. Since this time, the City of London and Department of National Defense legal teams have worked together in developing an agreement.

The purpose of this report is to recommend that Council approve a by-law and associated agreement between the Corporation of the City of London and the Canada Company to purchase a LAV III Public Art Monument, and to pass a by-law and associated licensing agreement between the Corporation of the City of London and the Department of National Defense (DND) to place this LAV III (owned by the City) at Wolseley Barracks on a permanent basis.

### **Canada Company LAV III Purchase Agreement (Appendix A)**

Appendix "A" of this report includes a recommended agreement and by-law to purchase a LAV III from the Canada Company. The agreement establishes the responsibilities of the parties with respect to payment, delivery, installation, maintenance, and other matters in relation to the LAV III Public Art Monument. The agreement includes a number of important details about the LAV III:

- **Ownership:** title for the monument would pass to the City of London upon delivery of the monument, subject to final agreement from the Canadian government from the Controlled Goods Program and the U.S. government in relation to the Non-transfer and Use Certificate;
- **Purchase Price:** the City of London will pay \$17,500 + applicable sales tax to the Canada Company for the LAV III monument;
- **Other Costs:** the City of London bears the costs for installation of the monument, including the concrete pad/pedestal, as well as landscaping, crane costs, affixing the monument to the pad/pedestal, and installing plaques;
- **Dedication:** all parties agree that the monument will be registered with the National Inventory of Canadian Military Memorials ("NICMM"), administered by the Department of National Defense's Directorate of History and Heritage National; and

- Indemnification, Insurance and Liability: the City of London has sole responsibility to determine what insurance coverage is necessary, and to indemnify and hold harmless the Canada Company from any claims, suits, damages and otherwise.

The application for a LAV III specifically requires an ongoing programming component, which contributed greatly to the selection of Wolseley Barracks as the location with a connection to the RCR Museum. The RCR Museum has an exhibit dedicated to the Afghanistan conflict which includes a replica of other vehicles associated with the LAV III. The RCR Museum will be responsible for the ongoing educational and commemorative programming centered on the Monument.

### **Department of National Defense Licensing Agreement (Appendix B)**

Appendix “B” of this report includes a recommended agreement and by-law for licensing between the Corporation of the City of London and the Department of National Defense (DND) for placement of the LAV III Public Art Monument at Wolseley Barracks (in the RCR Museum outdoor display area) on a permanent basis. The Department of National Defense 4<sup>th</sup> Canadian Division Support Group provided the City of London with a letter of approval on February 3, 2016, attached as Appendix “C” to this report, authorizing this installation to occur. The agreement includes a number of important details:

- Term: the agreement is for a five year period, noting that with two months written notice, the City can extend the term of the agreement for two additional five year terms;
- License Fee: the City of London will pay DND a sum of \$1 for use of the area identified in the agreement for placement of the LAV III; and
- Contamination – in the event that a deleterious substance or contaminant is discharged *by the Licensee (added by DND at the request of the City to ensure that the City is not responsible for any pre-existing contaminated soils)* during the use of the Licensed Area, then the Licensee shall and it does hereby undertake and agree to take such remedial, restorative or reconstructive measures as may be necessary to retrieve and remove the deleterious substance or the contaminant and to restore the Licensed Area or any other part of the Premises thereby contaminated as a result of the discharge, to its former state, all at the sole cost and expense of the Licensee and in full compliance with any and all regulatory authorities.

### **Budget & Source of Financing**

The Canada Company LAV III Monument Agreement includes the community total monument price of \$17,500 + HST, which includes the inclusion of the National Commemorative Program Plaque at a cost of \$2,500 to be displayed in the front of the monument. A refundable down payment of \$7,500 toward this Agreement cost has already been made. Each community also has the opportunity to create an additional customized plaque to convey localized messaging of significance as part of this project, which is estimated to cost up to \$5,000.

The City of London will assume full ownership of the LAV III Monument and be responsible for all project implementation, including transportation costs within London estimated to be approximately \$2,000. Militex Coatings Inc. will provide no-charge crane loading onto a tandem truck.

The City's Facilities Division was permitted by the Department of National Defense in 2016 to have a local structural engineering firm assess the existing concrete pad at Wolseley Barracks and it was determined that a new concrete pad would have to be poured to support the weight load of the LAV III and meet the required concrete pad specifications contained in the Canada Company LAV III Agreement. This firm has created stamped engineering drawings suitable for Wolseley Barracks and has prepared the budget below.

<b><u>Construction</u></b>	<b><u>Budget</u></b>
Demolition (existing concrete pad and sidewalks)	\$3,500.00
Hoarding and temporary fencing	\$2,000.00
Strip and stockpile native soils	\$500.00
Removals	\$1,500.00
Clear angular stone and compaction	\$1,200.00
Granular 'B' backfill and compaction	\$1,200.00
Concrete forming	\$1,200.00
Concrete supply and finish	\$7,000.00
Concrete reinforcing	\$2,400.00
Cast-in plates	\$300.00
Welding	\$300.00
Crane and installation	\$2,500.00
Replace native topsoil	\$500.00
Sod repair and/or replacement	\$800.00
<b>Sub-total</b>	<b>\$24,900.00</b>
<b><u>Administration</u></b>	
Site supervision	\$5,000.00
Temp. Washroom	\$300.00
Administration	\$2,500.00
Profits	\$3,500.00
<b>Sub-total</b>	<b>\$11,300.00</b>
<u>Contingency - 10%</u>	\$3,620.00
<b>Total</b>	<b>\$39,820.00</b>

As a City-owned monument, the ongoing maintenance costs will be covered through the City's Public Art Maintenance Fund and regular lifecycle maintenance program. Canada Company has indicated that the LAV III has been painted with a special anti-corrosive and anti-graffiti paint. The monument will need to be weather-proofed once every five to seven years to ensure its condition is maintained and that there are no holes where an animal could nest. Wolseley Barracks also has twenty-four hour on-site security to protect the monument.

Council resolved on April 5, 2016 that funding of up to \$100,000, to be drawn from the existing City of London Public Art Acquisition Reserve Fund be approved to implement the LAV III Public Art Monument Project.

### **Next Steps**

With Council approval of the agreements recommended in this report, there are still a number of steps which need to take place. Government approvals may take 2-3 months, and there will be time required to prepare the site for installation.

The next steps for London's LAV III are to:

1. Execute Canada Company LAV III Community Agreement.
2. Complete the DSP-83 form required by the US Department of State to complete ownership transfer approval. This form is entitled the Non-transfer and Use Certificate and is the last page attached of the community agreement.
3. Provide Canada Company with verification of the concrete pad installation through submission of stamped drawings.
4. Confirm all plaques being installed with the monument with Canada Company including the National Program Plaque.
5. Pay the balance of payment outstanding on the monument.
6. Tender the creation of the concrete pad. Pour and cure the concrete pad before arranging for pick-up of the monument with Canada Company. The program will store the monument until a collection date can be coordinated.
7. Transport of the LAV III from Militex Coatings Inc to Wolseley Barracks and install the monument and plaque signage
8. Confirm with Canada Company once installation has been completed and provide notice of the official unveiling ceremony date(s) to be hosted by the City and the RCR Museum with other partners.
9. Work with Canada Company to register the monument with the National Inventory of Canadian Military Memorials (NICMM).

<b>CONCLUSION</b>
-------------------

The City of London and The Royal Canadian Regiment (RCR) Museum continue to work together, with many other partners, to commemorate the contributions of Canadian veterans and Canada's military history. The LAV III represents an important opportunity to continue this effort, and will provide a lasting recognition of the important role that Canadians have played in peacekeeping efforts around the world.

<b>PREPARED BY:</b>	<b>RECOMMENDED BY:</b>
<b>ROBIN ARMISTEAD MANAGER OF CULTURE</b>	<b>KATE GRAHAM DIRECTOR, COMMUNITY AND ECONOMIC INNOVATION</b>

cc:

- Georgiana Stanciu, Executive Director, RCR Museum
- Shawn Deane, Project Manager LAV III Monument Program, Canada Company
- Judith Collins Property Officer Real Property Operations Unit, Department of National Defense
- Lieutenant-Colonel David Fearon, Chief of Staff, 31 Canadian Brigade Group Headquarters, Canadian Armed Forces
- Lieutenant-Colonel Don Saunders, Commanding Officer, Real Property Operations Unit, Canadian Armed Forces

- Appendix A - Canada Company LAV III Purchase Agreement
- Appendix B - Department of National Defense Licensing Agreement
- Appendix C - The Department of National Defense Letter of Approval

## APPENDIX A

Bill No.  
2017

By-law No.

A by-law to approve the LAV III Monument Agreement between Canada Company: Many Ways to Serve and The Corporation of the City of London; and to authorize the Mayor and the City Clerk to execute the Agreement.

WHEREAS subsection 5(3) of the *Municipal Act, 2001*, S.O. 2001, c. 25, as amended, provides that a municipal power shall be exercised by by-law;

NOW THEREFORE the Municipal Council of The Corporation of the City of London enacts as follows:

1. The LAV III Monument Agreement attached as Schedule "A" to this by-law between Canada Company: Many Ways to Serve and The Corporation of the City of London permitting the City to purchase the LAV III Monument is approved.
2. The Mayor and the City Clerk are authorized to execute the LAV III Monument Agreement approved under section 1 above.
3. This by-law shall come into force and effect on the day it is passed.

PASSED in Open Council \_\_\_\_\_, 2017.

Matt Brown  
Mayor

Catharine Saunders  
City Clerk

First reading -  
Second reading -  
Third reading -

**CANADA COMPANY: MANY WAYS TO SERVE**

**and**

**The Corporation of the City of London**

**London, Ontario**

---

**LAV III MONUMENT AGREEMENT**

Dated as of January 24, 2017

---

**STIKEMAN ELLIOTT LLP**

## TABLE OF CONTENTS

### ARTICLE 1 INTERPRETATION

Section 1.1	Defined Terms.....	1
Section 1.2	Currency. ....	2
Section 1.3	Incorporation of Schedules. ....	2
Section 1.4	References to Persons.....	2
Section 1.5	Statutes.....	2
Section 1.6	Non-Business Days. ....	2

### ARTICLE 2 DELIVERY, INSTALLATION AND MAINTENANCE

Section 2.1	Monument .....	3
Section 2.2	Preparation of the Location.....	3
Section 2.3	Delivery.....	3
Section 2.4	Installation.....	3
Section 2.5	Maintenance and Alteration .....	4

### ARTICLE 3 PURCHASE PRICE

Section 3.1	Purchase Price.....	4
Section 3.2	Payment Terms.....	4

### ARTICLE 4 DEDICATION

Section 4.1	National Inventory of Canadian Military Memorials .....	5
Section 4.2	Initial Unveiling.....	5

### ARTICLE 5 CONTROLLED GOODS

Section 5.1	Controlled Goods .....	6
Section 5.2	Nontransfer and Use Certificate.....	6

### ARTICLE 6 REPRESENTATIONS AND WARRANTIES

Section 6.1	Mutual Representations .....	6
Section 6.2	Representations of Canada Company .....	7

### ARTICLE 7 INDEMNIFICATION, INSURANCE AND LIABILITY

Section 7.1	Indemnification.....	7
Section 7.2	Insurance.....	7
Section 7.3	Exclusion of Liability .....	7



**ARTICLE 8  
MISCELLANEOUS**

Section 8.1	Notices.....	8
Section 8.2	Amendments.....	9
Section 8.3	Waiver.....	9
Section 8.4	Entire Agreement.....	9
Section 8.5	Successors and Assigns.....	9
Section 8.6	Severability.....	9
Section 8.7	Governing Law.....	9
Section 8.8	Counterparts.....	10

**ADDENDA**

- SCHEDULE A  
Legal Description of Lands or Land Use Authorization
- SCHEDULE B  
Monument Location
- SCHEDULE C  
Installation Guidelines
- SCHEDULE D  
Nontransfer and Use Certificate
- [SCHEDULE E  
Supporting Groups and Organizations<sup>1</sup>]

---

<sup>1</sup> Schedule E to be used when necessary.

## LAV III MONUMENT AGREEMENT

LAV III Monument Agreement (the “**Agreement**”) dated **January 24, 2017** between Canada Company: Many Ways to Serve (“**Canada Company**”) and **The Corporation of the City of London** (the “**Community**”).

### RECITALS:

- (1) **WHEREAS** Canada Company is a charitable, non-partisan organization that serves to build the bridge between business and community leaders and the men and women of the Canadian Armed Forces and their families;
- (2) **AND WHEREAS** Canada Company, in collaboration with the Canadian Department of National Defence, the Canadian Armed Forces, and Public Works and Government Services Canada, is the civilian administrator of a program to recognize the service of the Canadian Armed Forces in Afghanistan by providing replica Light Armoured Vehicles (“**LAV IIIs**”) as monuments (the “**Monuments**”) to qualifying communities throughout Canada;
- (3) **AND WHEREAS** the Community, having received prior approval of the Canada Company LAV III Monument selection committee (“**CCSC**”), wishes to acquire a Monument and Canada Company wishes to provide a Monument to the Community on the terms and conditions specified herein; [including, where applicable, support offered by other groups or organizations as identified in “Schedule E”];
- (4) **AND WHEREAS** the Community is either the registered owner of the lands described in Schedule “A” or has provided Canada Company the necessary land use authorization from the land owner;
- (5) **AND WHEREAS** the purpose of this Agreement is to set out the responsibilities of the Parties with respect to payment, delivery, installation, maintenance, and other matters in relation to the Monument.

**NOW THEREFORE** in consideration of the above and for other good and valuable consideration (the receipt and adequacy of which is acknowledged), the Parties agree as follows:

### ARTICLE 1 INTERPRETATION

#### Section 1.1 Defined Terms.

As used in this Agreement, the following terms have the following meanings:

“**Applicable Law**” means all applicable federal, provincial, municipal or local laws, statutes, regulations or by-laws.

**“Business Day”** means any day of the year, other than a Saturday, Sunday or holiday (which shall be any day on which Canadian chartered banks are closed for business in Toronto, Ontario).

**“CCSC”** means the Canada Company LAV III Monument selection committee.

**“Location”** means the proposed location of the Monument, as approved by Canada Company and as set forth in Schedule “B”.

**“Monument”** means a replica LAV III assembled under the supervision of Militex Coatings Inc., using parts from decommissioned and partially demilitarized LAV IIIs declared surplus by the Canadian Government.

**“NICMM”** means the National Inventory of Canadian Military Memorials.

**“Notice”** has the meaning set out in Section 8.1.

**“Party”** means any one of Canada Company and the Community.

**“Person”** means an individual, partnership, limited partnership, limited liability partnership, corporation, limited liability company, unlimited liability company, joint stock company, trust, unincorporated association, joint venture or other entity or governmental entity, and pronouns have a similarly extended meaning.

### **Section 1.2 Currency.**

All references in this Agreement to dollars or to “\$” are expressed in Canadian currency unless otherwise specifically indicated.

### **Section 1.3 Incorporation of Schedules.**

The schedules attached to this Agreement form an integral part of it.

### **Section 1.4 References to Persons.**

Any reference in this Agreement to a Person includes its heirs, administrators, executors, legal representatives, successors and permitted assigns.

### **Section 1.5 Statutes.**

Except as otherwise provided in this Agreement, any reference in this Agreement to a statute refers to such statute and all rules and regulations made under it as it or they may have been, or may from time to time be, amended, re-enacted or replaced.

### **Section 1.6 Non-Business Days.**

Whenever payments are to be made or an action is to be taken on a day which is not a Business Day, such payment must be made or such action must be taken on or not later than the next succeeding Business Day.

**ARTICLE 2  
DELIVERY, INSTALLATION AND MAINTENANCE**

**Section 2.1 Monument**

- (1) Canada Company hereby agrees to provide and the Community agrees to accept one Monument on the terms and conditions set forth herein.
- (2) Title to the Monument shall pass to the Community upon delivery of the Monument at London, Ontario.
- (3) Notwithstanding the above, Canada Company, in its sole discretion, to be exercised honestly and in good faith, may terminate this Agreement at any time before the delivery of the Monument to the Community if, in the opinion of the CCSC, the Community no longer qualifies as an approved Community. In such circumstances, the Community will be given 30 days' notice of termination and an opportunity to cure the defect or unresolved issue that has, in the opinion of the CCSC, disqualified the Community, with each Party to have no recourse against the other for any costs or losses incurred in the performance of the Agreement up to the point of termination, and any Deposit (as defined in Article 3 below) shall be returned to the Community.
- (4) This Agreement is contingent upon Canadian and U.S. government approvals and will become null and void in the event that the Community fails to receive Canadian government final approval from the Controlled Goods Program or U.S. government final approval in relation to the Nontransfer and Use Certificate described further in Article 5. The Parties agree that where it is clear that such final approval will not be granted, this Agreement will be deemed to be null and void and each Party will have no recourse against the other for any costs or losses incurred in the performance of the Agreement up to that point and any Deposit (as defined in Article 3 below) shall be returned to the Community.

**Section 2.2 Preparation of the Location**

Prior to delivery, the Community shall, at its own cost and expense and in compliance with the specifications set out in Schedule "C", prepare the concrete pad/pedestal on which the Monument will be mounted.

**Section 2.3 Delivery**

The Community shall be responsible for arranging, coordinating and paying for the delivery of the Monument from London, Ontario to the approved Location. The Community agrees to notify and consult with Canada Company on the delivery arrangements.

**Section 2.4 Installation**

The Parties agree that all costs of installation of the Monument at the Location shall be at all times the responsibility of the Community. The Monument will include one

commemorative plaque, to be installed at no cost to the Community. The cost of installing supplementary plaques, if any, shall be the responsibility of the Community. The Community's Monument installation costs include but are not limited to the preparation of the Location and the pad/pedestal, landscaping, crane costs, affixing the Monument to the pad/pedestal, and installing supplementary plaques. The Community will be responsible for contracting for the installation of the Monument and any supplementary plaques, subject to compliance with the Controlled Goods Program as well as consultation with and prior approval of Canada Company. All standard safety precautions must be taken on-site during installation and include clearing the area of tools and equipment, fencing the area if required, and ensuring that all persons present, including volunteers, paid workers and the general public, comply with Applicable Law and follow appropriate safety guidelines.

### **Section 2.5 Maintenance and Alteration**

After installation, the Community shall, at its own cost and expense, keep and maintain the whole of the Monument and associated plaques in good order, condition and repair, subject to reasonable wear and tear. The Community agrees that it will not sell, relocate, or intentionally destroy, damage, alter or change all or any part of the Monument in any way unless absolutely necessary. The Community will make all reasonable efforts to notify Canada Company of any such alteration that would significantly affect the intended character and appearance of the Monument, and in such cases Canada Company reserves the right to require the removal, at the Community's cost, of any public notice associating Canada Company or national program sponsors with the Monument.

## **ARTICLE 3 PURCHASE PRICE**

### **Section 3.1 Purchase Price**

The consideration payable by the Community to Canada Company for the Monument and one commemorative plaque FOB London, Ontario is \$17,500 plus applicable sales tax (the "**Purchase Price**"). [NTD: generally speaking, the applicable sales tax will be Ontario's 13% HST since the "place of supply" will be Ontario. However, communities in Alberta and the territories may wish to take advantage of delivery arrangements that will result in the place of supply being the destination province/territory - see GST/HST Technical Information Bulletin B-103, *Harmonized Sales Tax - Place of supply rules for determining whether a supply is made in a province* (June 2012)]

### **Section 3.2 Payment Terms**

(1) Payment of the Purchase Price shall be in two parts, (i) a deposit of \$7,500 (the "**Deposit**") which is non-refundable except where required government approvals are not granted for reasons beyond the control of the Community, and (ii) the balance of the Purchase Price in the form of a payment of \$10,000 plus applicable sales tax (the "**Balance Payment**").

(a) **The Deposit** - Terms of payment for the Deposit shall be net thirty (30) days from the receipt of an invoice (the "**Deposit Invoice**") from Canada

Company, which may be sent at any time after the Community has been pre-approved by the CCSC or as the Parties may otherwise agree. Failure to provide the Deposit within thirty (30) days of receipt of the Deposit Invoice will result in the Community forfeiting its ranking for delivery of a Monument to other pre-approved communities. The Community can re-enter the approval process by notifying Canada Company that the Deposit funds are available, but, for clarity, in such a case the Community will not rank ahead of other communities whose Deposits have been received in the interim. The Community acknowledges that the Deposit will be applied toward Monument program costs and will be credited toward the Purchase Price. The Parties acknowledge and agree that the Deposit accurately reflects Monument replication and other unrecoverable program costs in connection with preparing a Monument for the Community.

- (b) **Deposit Refund** - If Canada Company, acting reasonably, is satisfied that one or more of the approvals described in Article 5 will not be granted for reasons beyond the control of the Community, also acting reasonably, the Community can submit a written request for a full refund of the Deposit ("**Refund Request**"). No Refund Request may be submitted in the first six (6) months following receipt by Canada Company of the Deposit. Canada Company will refund the Deposit, without interest, within forty-five (45) days of receipt of a valid Refund Request. The Community acknowledges that if it submits a Refund Request it will forfeit its place within the Monument program's community ranking.
- (c) **Balance Payment** - Terms of payment for the Balance Payment shall be net thirty (30) days from the receipt of an invoice (the "**Balance Payment Invoice**") from Canada Company, which may be sent at any time after Canada Company has been notified by [Militex Coatings Inc.] that the Monument ear-marked for the Community has been completed and is ready for pick-up from London, Ontario.

## ARTICLE 4 DEDICATION

### **Section 4.1 National Inventory of Canadian Military Memorials**

The Parties acknowledge and agree that the Monument will be registered with the National Inventory of Canadian Military Memorials ("**NICMM**"), administered by the Department of National Defence's Directorate of History and Heritage. Canada Company will register the Monument with NICMM in the first instance, and thereafter it will be incumbent on the Community to notify NICMM of relevant changes, if any.

### **Section 4.2 Initial Unveiling**

The Community agrees that for the first official unveiling of the Monument ("**Initial Unveiling**"), the Community will give reasonable notice to Canada Company of the date and time of the Initial Unveiling and will give Canada Company, or its designated

representative (who may be an individual from a national program sponsor), an opportunity to speak about the LAV III Monument program at the Initial Unveiling.

## ARTICLE 5 CONTROLLED GOODS

### **Section 5.1      Controlled Goods**

The Community agrees that it will comply with all applicable requirements of the **Controlled Goods Program** (“CGP”) under the *Controlled Goods Regulations* (Canada) of the *Defence Production Act* (Canada). Such requirements may include but are not limited to applying for registration under the CGP, appointing a Designated Official (who will complete the Designated Official Certification Program), consenting to security assessments, adopting and implementing a security plan, conducting security assessment evaluations, putting in place appropriate measures to prevent the unauthorized removal and examination of the Monument, adhering to proper disposal procedures and otherwise complying with the obligations of the CGP.

### **Section 5.2      Nontransfer and Use Certificate**

The Community agrees that it will complete, sign and return to Canada Company a U.S. Department of State *Nontransfer and Use Certificate DSP-83* in the form attached at Schedule “D”.

## ARTICLE 6 REPRESENTATIONS AND WARRANTIES

### **Section 6.1      Mutual Representations**

- (1) Without limiting the generality of any other provision of this Agreement, each Party represents to the other, and acknowledges that the other is relying on such representations in entering into this Agreement, as follows:
  - (a) it has the requisite power, authority and capacity to enter into this Agreement and to perform its obligations hereunder;
  - (b) this Agreement has been duly authorized, executed and delivered by it and constitutes a valid and binding obligation enforceable against it in accordance with its terms except as such enforcement may be limited by bankruptcy, insolvency and other laws of overriding effect and except that equitable remedies may only be granted in the discretion of a court of competence jurisdiction;
  - (c) the execution and delivery of this Agreement and the consummation of the transactions contemplated hereby will not result in the breach or violation of any of the provisions of, or constitute a default under, or conflict with or cause the termination, cancellation or acceleration of, its material obligations

or any judgment, decree, order or award to which it is subject or any license, permit, approval, consent or authorization held by it; and

- (d) each Party agrees that it will not use the Monument or a Party's name in a way which might bring the Monument or a Party into disrepute.

## **Section 6.2 Representations of Canada Company**

- (1) Canada Company represents and warrants to the Community, and acknowledges that the Community is relying on such representations and warranties in entering into this Agreement, as follows:
  - (a) there are no bankruptcy, insolvency, reorganization, receivership, seizure, realization, arrangement or other similar proceedings pending against, or being contemplated by Canada Company or, to the knowledge of Canada Company, threatened against Canada Company; and
  - (b) except as herein described, there are no actions, suits, proceedings, judgments, rulings or orders by or before any governmental authority, or, to the knowledge of Canada Company, threatened against Canada Company, that could have a material adverse effect on Canada Company or the Monument.

## **ARTICLE 7 INDEMNIFICATION, INSURANCE AND LIABILITY**

### **Section 7.1 Indemnification**

The Community shall indemnify, hold harmless and defend Canada Company and its directors, officers, employees, agents, and members (collectively, "**Indemnified Parties**") from and against all claims, demands, actions, suits, damages, liabilities, losses, settlements, judgments, costs and expenses (including but not limited to reasonable lawyers' fees and costs), whether or not involving a third party claim, which arise out of or relate to (1) any breach of any representation or warranty of the Community contained in this Agreement, and/or (2) any breach or violation of any covenant or other obligation or duty of the Community under this Agreement or under Applicable Law.

### **Section 7.2 Insurance**

It shall be the sole responsibility of the Community to determine what insurance coverage is necessary and advisable for its own protection during the delivery, installation and thereafter and/or to fulfill its obligations under this Agreement.

### **Section 7.3 Exclusion of Liability**

CANADA COMPANY MAKES NO REPRESENTATIONS OR WARRANTIES AS TO THE QUALITY OF THE DESIGN, FITNESS, FABRICATION AND/OR INSTALLATION OF THE MONUMENT AND IN NO EVENT SHALL CANADA COMPANY BE LIABLE FOR



ANY DAMAGES ARISING FROM ANY SUCH DEFECT OR DEFICIENCY. NEITHER PARTY SHALL BE LIABLE TO THE OTHER PARTY FOR ANY SPECIAL, INCIDENTAL, OR CONSEQUENTIAL DAMAGES ARISING OUT OF THIS AGREEMENT.

**ARTICLE 8  
MISCELLANEOUS**

**Section 8.1 Notices.**

Any notice, direction or other communication given pursuant to this Agreement (each a “**Notice**”) must be in writing, sent by personal delivery, courier, facsimile or email and addressed:

- (1) to Canada Company at:

Toronto-Dominion Centre  
TD Bank Tower  
66 Wellington Street West  
P.O. Box 314, Suite 3100  
Toronto, ON, M5K 1K2

Attention: Shawn Deane, Project Manager, LAV III Monument Program  
Telephone: 416-869-8456, 416-865-4311  
Email: shawn.deane@canadacompany.ca, info@canadacompany.ca

- (2) to the Community at:

**The Corporation of the City of London**

P.O. Box 5035 300 Dufferin Avenue, London, ON N6A 4L9

Attention: Catharine Saunders, City Clerk  
Telephone: 519-661-2500 ext 4937  
Facsimile: 519-661-5920  
Email: csaunders@london.ca

A Notice is deemed to be given and received (i) if sent by personal delivery or courier, on the date of delivery if it is a Business Day and the delivery was made prior to 4:00 p.m. (local time in place of receipt) and otherwise on the next Business Day, or (ii) if sent by facsimile, on the Business Day following the date of confirmation of transmission by the originating facsimile or (iii) if sent by email, when the sender receives an email from the recipient acknowledging receipt, provided that an automatic “read receipt” does not constitute acknowledgment of an email for purposes of this Section 8.1. A Party may change its address for service from time to time by providing a Notice in accordance with the foregoing. Any subsequent Notice must be sent to the Party at its changed address. Any element of a Party’s address that is not specifically changed in a Notice will be assumed not to be changed.

**Section 8.2 Amendments.**

This Agreement may only be amended, supplemented or otherwise modified by written agreement signed by all of the Parties.

**Section 8.3 Waiver.**

No waiver of any of the provisions of this Agreement will constitute a waiver of any other provision (whether or not similar). No waiver will be binding unless executed in writing by the Party to be bound by the waiver. A Party's failure or delay in exercising any right under this Agreement will not operate as a waiver of that right. A single or partial exercise of any right will not preclude a Party from any other or further exercise of that right or the exercise of any other right it may have.

**Section 8.4 Entire Agreement.**

This Agreement constitutes the entire agreement between the Parties with respect to the transactions contemplated by this Agreement and supersedes all prior agreements, understandings, negotiations and discussions, whether oral or written, of the Parties with respect to such transactions. There are no representations, warranties, covenants, conditions or other agreements, express or implied, collateral, statutory or otherwise, including implied warranties or conditions of merchantability or fitness for a particular purpose, between the Parties in connection with the subject matter of this Agreement, except as specifically set forth in this Agreement.

**Section 8.5 Successors and Assigns.**

- (1) This Agreement becomes effective when executed by all of the Parties. After that time, it will be binding upon and enure to the benefit of the Parties and their respective successors, legal representatives and permitted assigns.
- (2) Neither this Agreement nor any of the rights or obligations under this Agreement may be assigned or transferred, in whole or in part, by any Party without the prior written consent of the other Party.

**Section 8.6 Severability.**

If any provision of this Agreement is determined to be illegal, invalid or unenforceable, that provision will be severed from this Agreement and the remaining provisions will remain in full force and effect.

**Section 8.7 Governing Law.**

- (1) This Agreement is governed by, and will be interpreted and construed in accordance with, the laws of the Province of Ontario and the federal laws of Canada applicable therein.

- (2) Each Party irrevocably attorns and submits to the exclusive jurisdiction of the courts of Ontario situated in the City of Toronto.

**Section 8.8 Counterparts.**

This Agreement may be executed in any number of counterparts, each of which is deemed to be an original, and such counterparts together constitute one and the same instrument. Transmission of an executed signature page by facsimile, email or other electronic means is as effective as a manually executed counterpart of this Agreement.

**[Remainder of page intentionally left blank. Signature page follows.]**

The Parties have executed this Agreement.

**THE CORPORATION OF THE CITY OF  
LONDON**

**THE CORPORATION OF THE CITY OF  
LONDON**

By: \_\_\_\_\_  
Authorized Signatory

By: \_\_\_\_\_  
Authorized Signatory

\_\_\_\_\_  
Printed Name

\_\_\_\_\_  
Printed Name

**CANADA COMPANY: MANY WAYS TO  
SERVE**

By: \_\_\_\_\_  
Authorized Signatory

\_\_\_\_\_  
Printed Name

**Signature page to LAV III Monument Agreement.**

## **SCHEDULE A**

### **Legal Description of Lands or Land Use Authorization**

Part of Lot 12, Concession 1 in the geographic Township of London, now City of London  
and County of Middlesex

## **SCHEDULE B**

### **Monument Location**

The Royal Canadian Regiment Museum Outdoors Display Area

Wolseley Barracks

701 Oxford Street East,

London, Ontario

N5Y 4T7

## SCHEDULE C

### Installation Guidelines

#### Installation guidelines

[description of structural requirements and dimensions of concrete pad/pedestal and anchoring, load bearing and stability requirements for installation of the Monument; see following page(s)]

# LAV III MONUMENT

STAMPED CONCRETE PAD MONUMENT V2

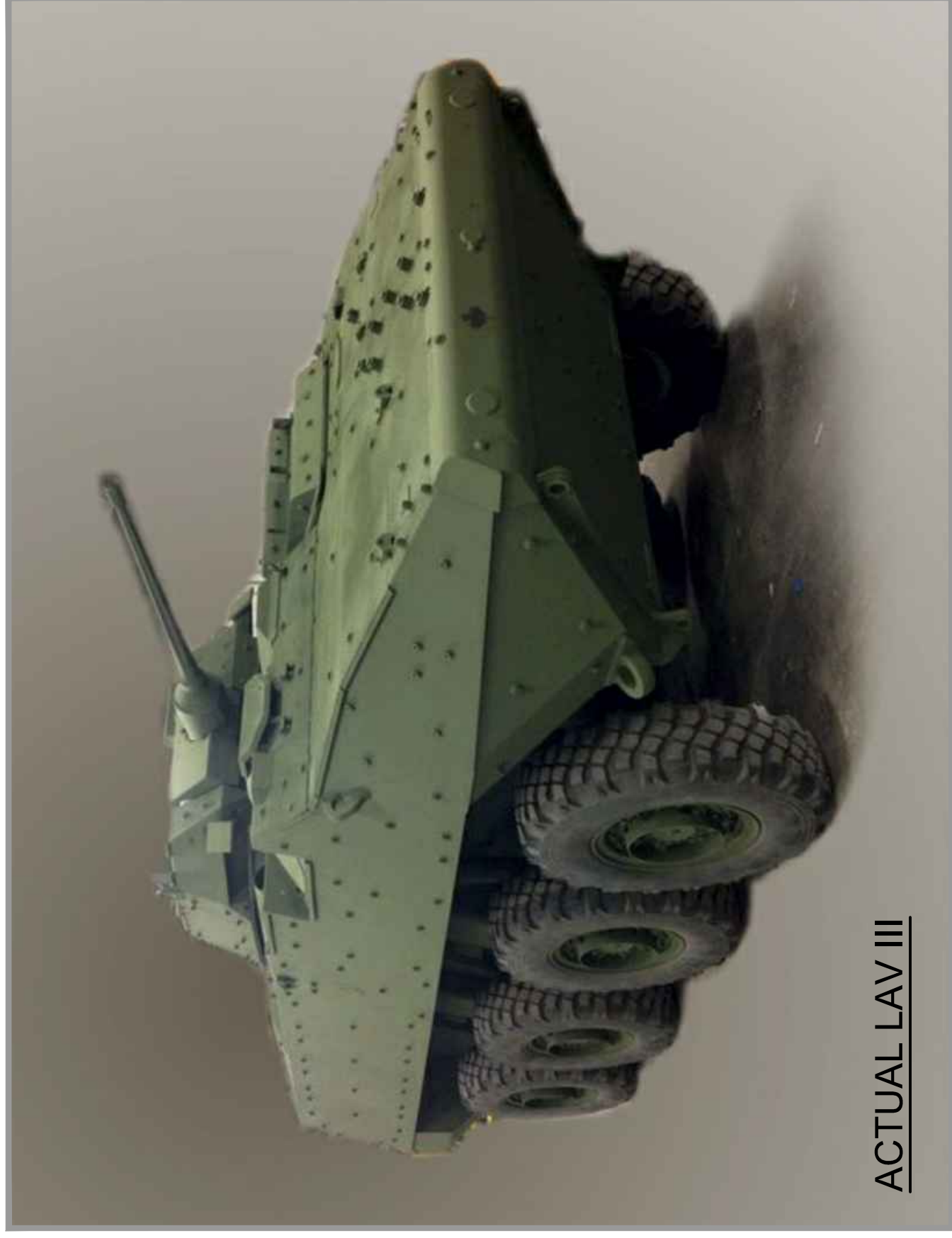

**NOT FOR CONSTRUCTION**

CONTACT LOCAL AUTHORITIES REGARDING ZONING BYLAWS, PLANNING GUIDELINES, ENGINEERING, BUILDING PERMITS AND OBTAIN UNDERGROUND LOCATES PRIOR TO INSTALLATION OF MONUMENT

STATIC

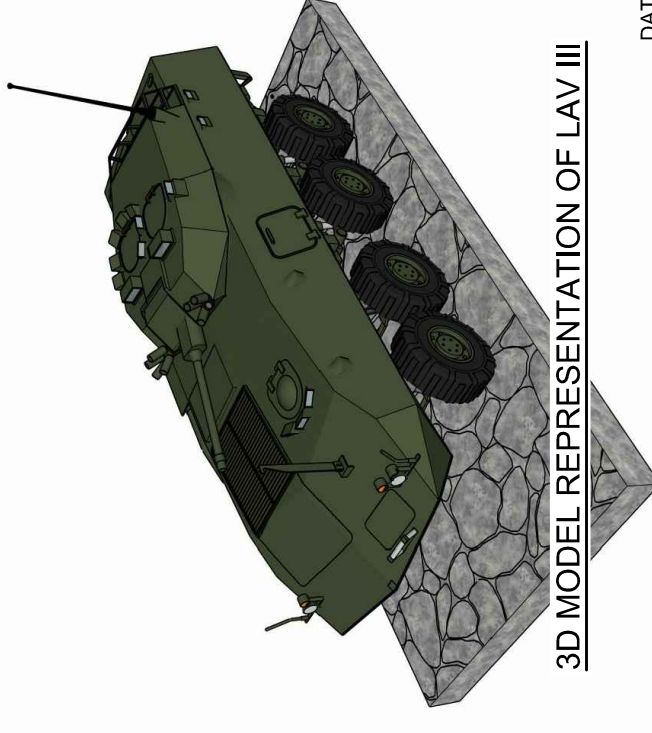
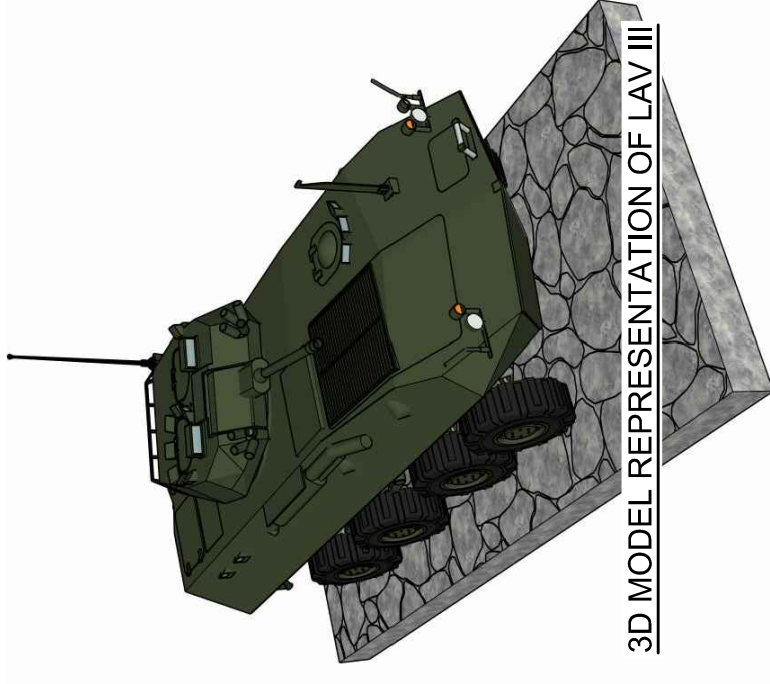

3D MODEL REPRESENTATION OF LAV III

REV:1

DATE: MAY 2, 2016



## CONSTRUCTION NOTES:

### A. CONCRETE

1. CONCRETE WORK SHALL CONFORM TO CAN/CSA-A23.1, A23.2 AND A23.3. CONCRETE PROPERTIES:

CONCRETE PROPERTIES		CSA CLASS	28 DAY COMP. STRENGTH MPa	MAX. W/C RATIO	AIR CONTENT %	MAX. AGGREGATE 3/3	SLUMP 3
LOCATION							
EXTERIOR PIERS AND WALLS		F-2	25	0.55	4-7	20	80 ±30
EXTERIOR CONCRETE SLABS (REINFORCED)		C-1	35	0.40	5-8	20	80 ±30

2. CONCRETE DESIGN IS BASED ON COMPRESSIVE STRENGTH. PHYSICAL PROPERTIES (SLUMP, AGGREGATE SIZE, ETC.) TO SUIT INSTALLATION (BY OTHERS) NOT TO AFFECT STRENGTH SPECIFIED.
3. ALL CONCRETE SHALL BE TESTED BY A CSA CERTIFIED CONCRETE TESTING LABORATORY. CONTRACTOR TO PROVIDE COPIES OF TESTING REPORTS TO THE ENGINEER. NOT LESS THAN ONE TEST SHALL BE MADE FOR EACH 100m<sup>3</sup> OF CONCRETE WITH AT LEAST ONE TEST FOR EACH CLASS OF CONCRETE USED. A MINIMUM OF THREE TESTS IS REQUIRED FOR EACH CLASS.
4. SLUMP OF CONCRETE TO BE 80mm +/- 30mm PRIOR TO SUPER PLASTICIZERS BEING ADDED.
5. ALL CONCRETE FORMS ARE TO BE WET THOROUGHLY PRIOR TO PLACING CONCRETE. WATER CURING OF CONCRETE IS RECOMMENDED.
6. DO NOT ADD WATER TO THE CONCRETE.
7. ALL CONCRETE EXCEPT FOR CONCRETE SLABS 150mm (6") OR LESS SHALL BE MECHANICALLY VIBRATED.
8. CONTROL JOINTS IN CONCRETE SLABS ON GRADE ARE TO BE SPACED AT MAXIMUM 30 TIMES THE SLAB THICKNESS NOT TO EXCEED 4500mm (15'-0) AND A DEPTH OF 1/4 THE THICKNESS OF THE SLAB. CUT 50% OF THE REINFORCING STEEL AT CONTROL JOINT LOCATIONS.
9. REINFORCING STEEL SHALL CONFORM TO CAN/CSA-G30.18. REINFORCING BARS SHALL BE DEFORMED, GRADE 400 MPa.
10. MAINTAIN THE FOLLOWING CONCRETE CLEAR COVER TO REINFORCING:
  - a) 75mm (3") FOR CONCRETE CAST AGAINST EARTH
  - b) 38mm (1 1/2") FOR CONCRETE CAST AGAINST FORMWORK
  - c) 64mm (2 1/2") FOR CONCRETE EXPOSED TO DE-ICING CHEMICALS
11. ALL REINFORCING STEEL, DOWELS AND ANCHOR BOLTS ARE TO BE CLEAN AND FREE OF RUST, DIRT, FORM RELEASE AGENT, ETC. PRIOR TO POURING CONCRETE.
12. LAP REINFORCING STEEL MINIMUM 36 TIMES THE BAR DIAMETER. LAP ALL HORIZONTAL BARS AT CORNERS WITH BENT DOWELS MEETING THE MINIMUM LAP REQUIREMENTS IN BOTH DIRECTIONS. SHOP FABRICATE ALL REINFORCING STEEL TO INCLUDE HOOKS AND BENDS.
13. REINFORCING STEEL, DOWELS AND ANCHOR BOLTS ARE TO BE SECURELY TIED PRIOR TO PLACING CONCRETE. REINFORCING STEEL CHAIRS AND SUPPORTS SHALL BE MADE OF CONCRETE BLOCKS, PLASTIC OR WIRE.
14. DOWELS SHALL MATCH REINFORCING UNLESS NOTED OTHERWISE.

### B. STRUCTURAL STEEL

1. STRUCTURAL STEEL SHALL CONFORM TO CAN/CSA-S16-01 AND THE CISC CODE OF STANDARD PRACTICE.
2. STRUCTURAL STEEL SHALL CONFORM TO CAN/CSA G40.20-04, G40.21-04 GRADE 350W CLASS C FOR H.S.S. AND G40.21-04 GRADE 350W FOR W SHAPE SECTIONS.
3. ANCHOR BOLTS SHALL BE FABRICATED USING STEEL ROD CONFORMING TO CSA G40.21 GRADE 300W.
4. WELDING SHALL CONFORM TO CSA W59 AND CSA W47 DIVISION 1 OR DIVISION 2.1 BY THE CANADIAN WELDING BUREAU. WELDING SHALL BE COMPLETED BY CWB CERTIFIED FABRICATOR AND ERECTOR TO THE CSA STANDARDS W178.1 AND W178.2.
5. STRUCTURAL STEEL EXPOSED TO WEATHER IS TO BE HOT DIP GALVANIZED CONFORMING TO CAN/CSA-G164. ALL COATINGS ARE TO BE TOUCHED UP ON SITE WITH APPROVED PAINT FOR PRIMED STEEL AND ZINC RICH PAINT FOR GALVANIZED STEEL.

### C. GENERAL

1. CONTACT A LOCAL GEOTECHNICAL ENGINEER TO VERIFY SOIL BEARING CAPACITIES PRIOR TO CONSTRUCTION

**NOT FOR CONSTRUCTION**

CONTACT LOCAL AUTHORITIES REGARDING ZONING BYLAWS, PLANNING GUIDELINES, ENGINEERING, BUILDING PERMITS AND OBTAIN UNDERGROUND LOCATES PRIOR TO INSTALLATION OF MONUMENT

## FOUNDATION SCHEDULE V2

MARK	SL'S SOIL BEARING CAPACITY (psf)	SIZE	REINFORCING
P1	1000	2286mm x 1067mm x 450mm	4-15M LONG + 8-15M SHORT (BOTTOM)
	1500	2134mm x 915mm x 450mm	3-15M LONG + 8-15M SHORT (BOTTOM)
	3000	1981mm x 762mm x 450mm	3-15M LONG + 7-15M SHORT (BOTTOM)
P2	1000	1524mm x 915mm x 450mm	3-15M LONG + 6-15M SHORT (BOTTOM)
	1500	1270mm x 762mm x 450mm	3-15M LONG + 5-15M SHORT (BOTTOM)
	3000	1219mm x 610 x 450mm	3-15M LONG + 5-15M SHORT (BOTTOM)

CONTACT A LOCAL GEOTECHNICAL ENGINEER TO VERIFY SOIL BEARING CAPACITIES PRIOR TO CONSTRUCTION

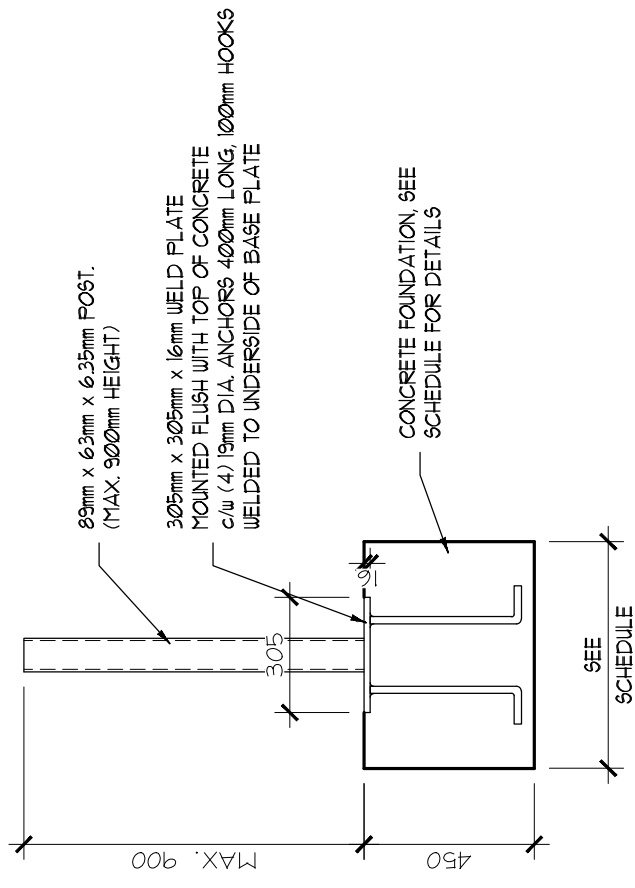
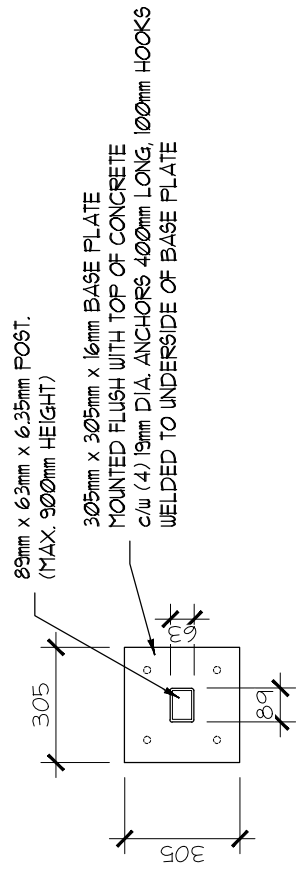

**NOT FOR CONSTRUCTION**

CONTACT LOCAL AUTHORITIES REGARDING ZONING BYLAWS, PLANNING GUIDELINES, ENGINEERING, BUILDING PERMITS AND OBTAIN UNDERGROUND LOCATES PRIOR TO INSTALLATION OF MONUMENT

**NOTE:**  
LAV III WEIGHTS 23,500 lbs.

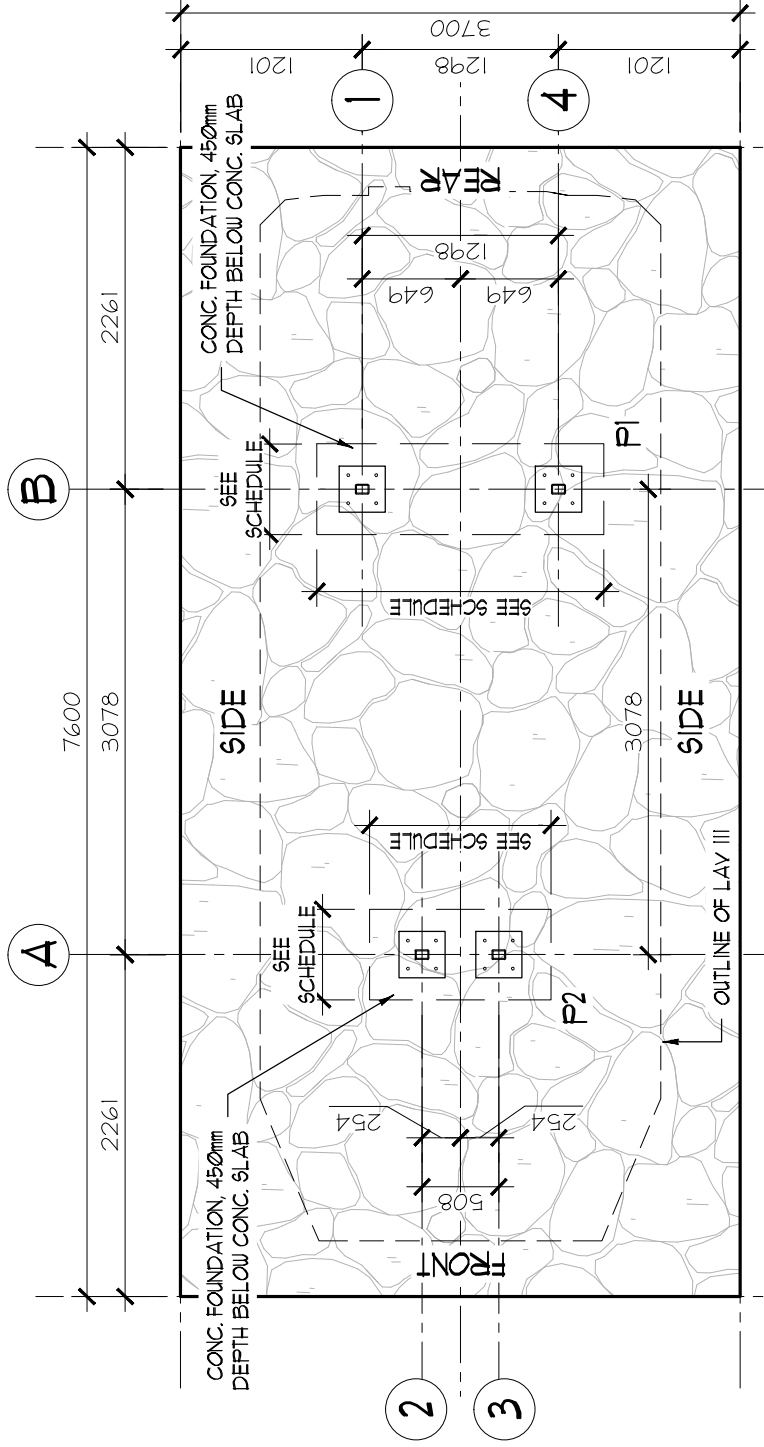

**STEEL COLUMN / PIER LAYOUT**

SCALE: 1:50

**FOUNDATION SCHEDULE v2**

MARK	SLG SOIL BEARING CAPACITY (psf)	SIZE	REINFORCING
P1	1000	2286mm x 1067mm x 400mm	4-15M LONG + 8-15M SHORT (BOTTOM)
	1500	2134mm x 915mm x 400mm	3-15M LONG + 8-15M SHORT (BOTTOM)
P2	3000	1981mm x 762mm x 400mm	3-15M LONG + 7-15M SHORT (BOTTOM)
	1000	1524mm x 915mm x 400mm	3-15M LONG + 6-15M SHORT (BOTTOM)
	1500	1210mm x 762mm x 400mm	3-15M LONG + 5-15M SHORT (BOTTOM)
	3000	1219mm x 610 x 400mm	3-15M LONG + 5-15M SHORT (BOTTOM)

**STATIC**

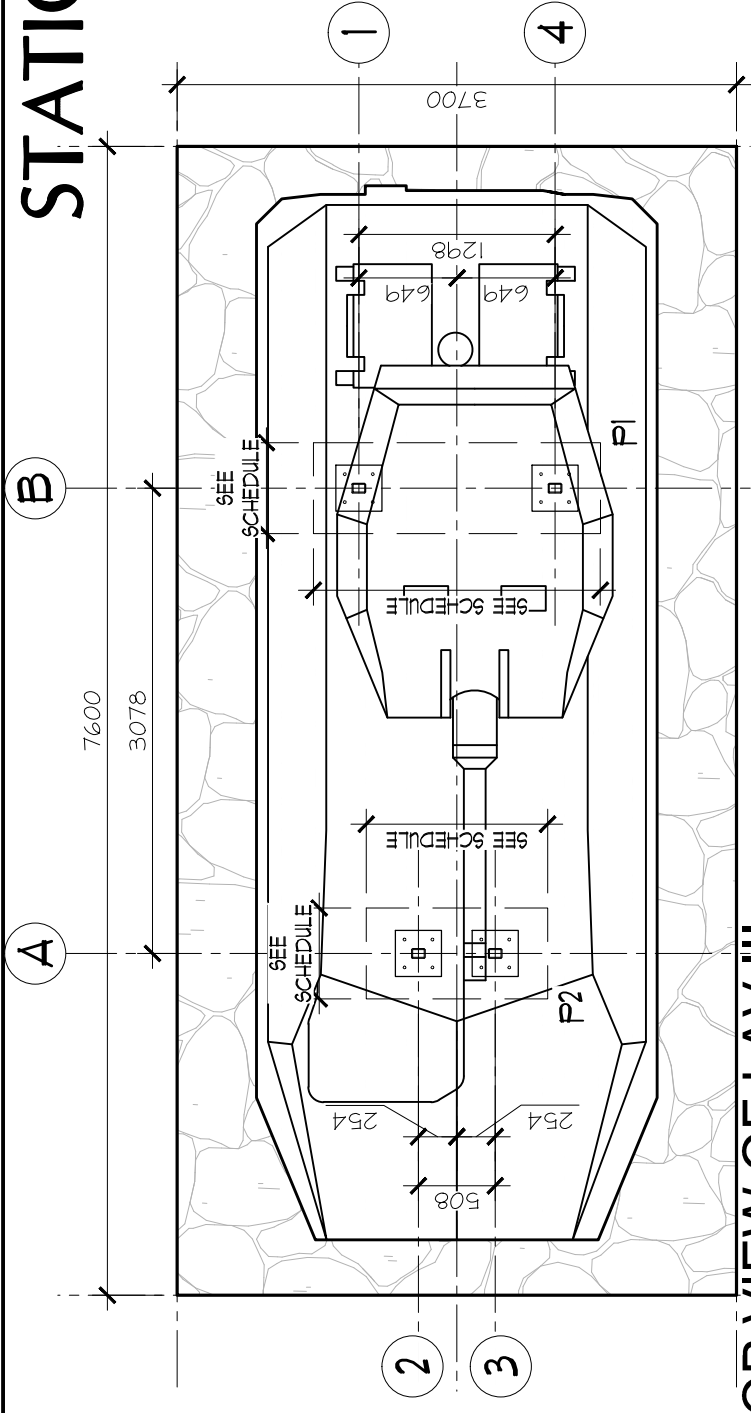

**TOP VIEW OF LAV III**

SCALE: 1:50

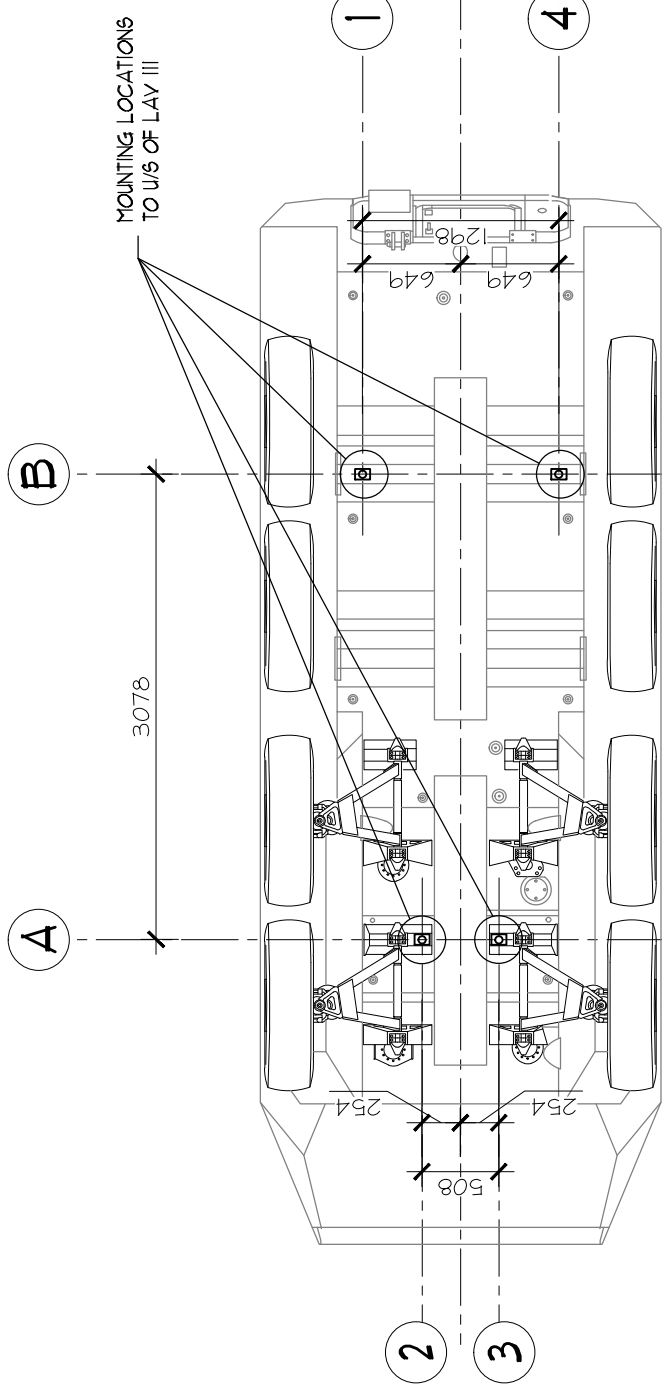

**UNDERSIDE VIEW OF LAV III**

SCALE: 1:50

**NOT FOR CONSTRUCTION**  
CONTACT LOCAL AUTHORITIES REGARDING ZONING BYLAWS, PLANNING GUIDELINES, ENGINEERING, BUILDING PERMITS AND OBTAIN UNDERGROUND LOCATES PRIOR TO INSTALLATION OF MONUMENT

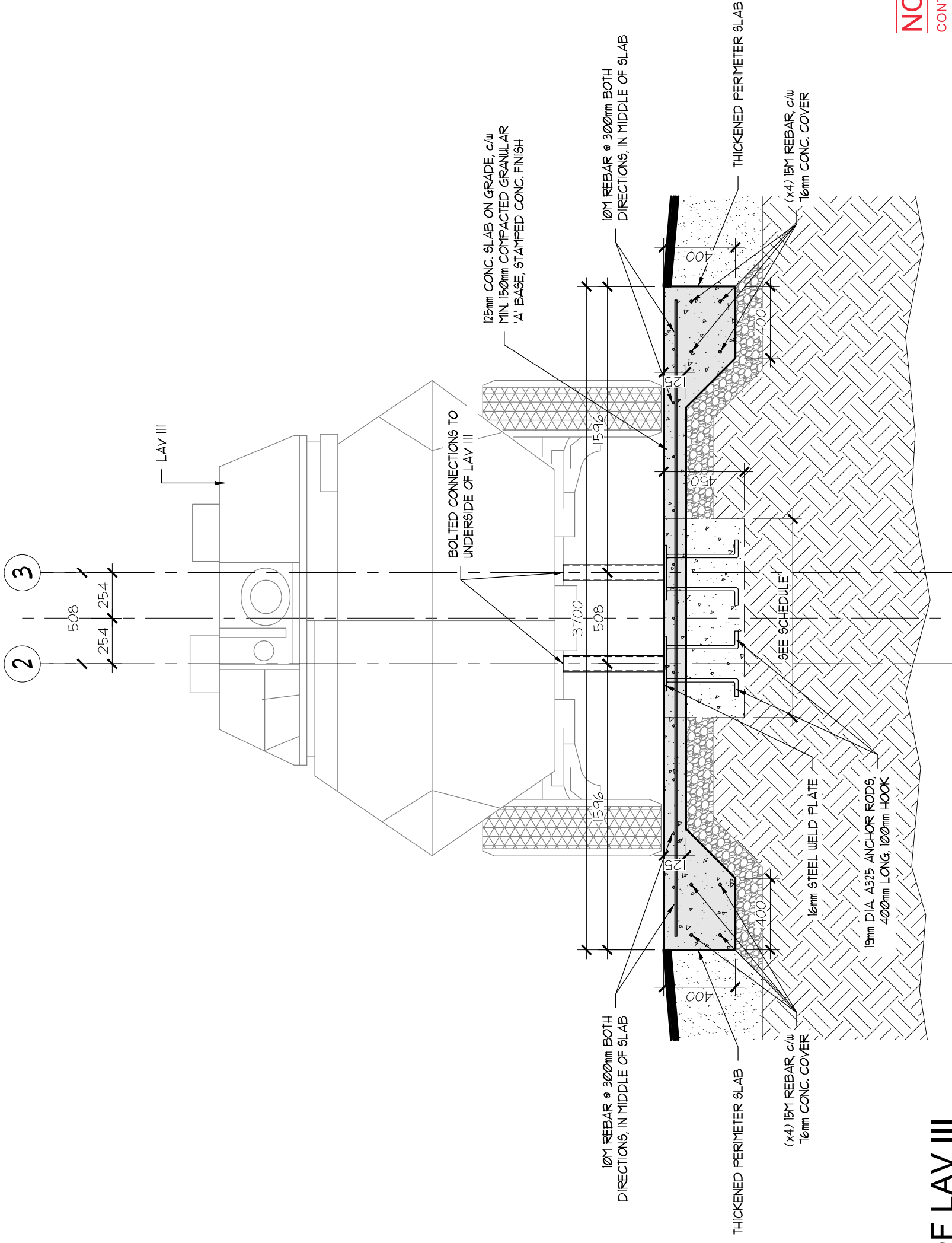

**NOT FOR CONSTRUCTION**

CONTACT LOCAL AUTHORITIES REGARDING ZONING BYLAWS, PLANNING GUIDELINES, ENGINEERING, BUILDING PERMITS AND OBTAIN UNDERGROUND LOCATES PRIOR TO INSTALLATION OF MONUMENT

FRONT VIEW OF LAV III

SCALE= 1:25

DWG:

STATIC

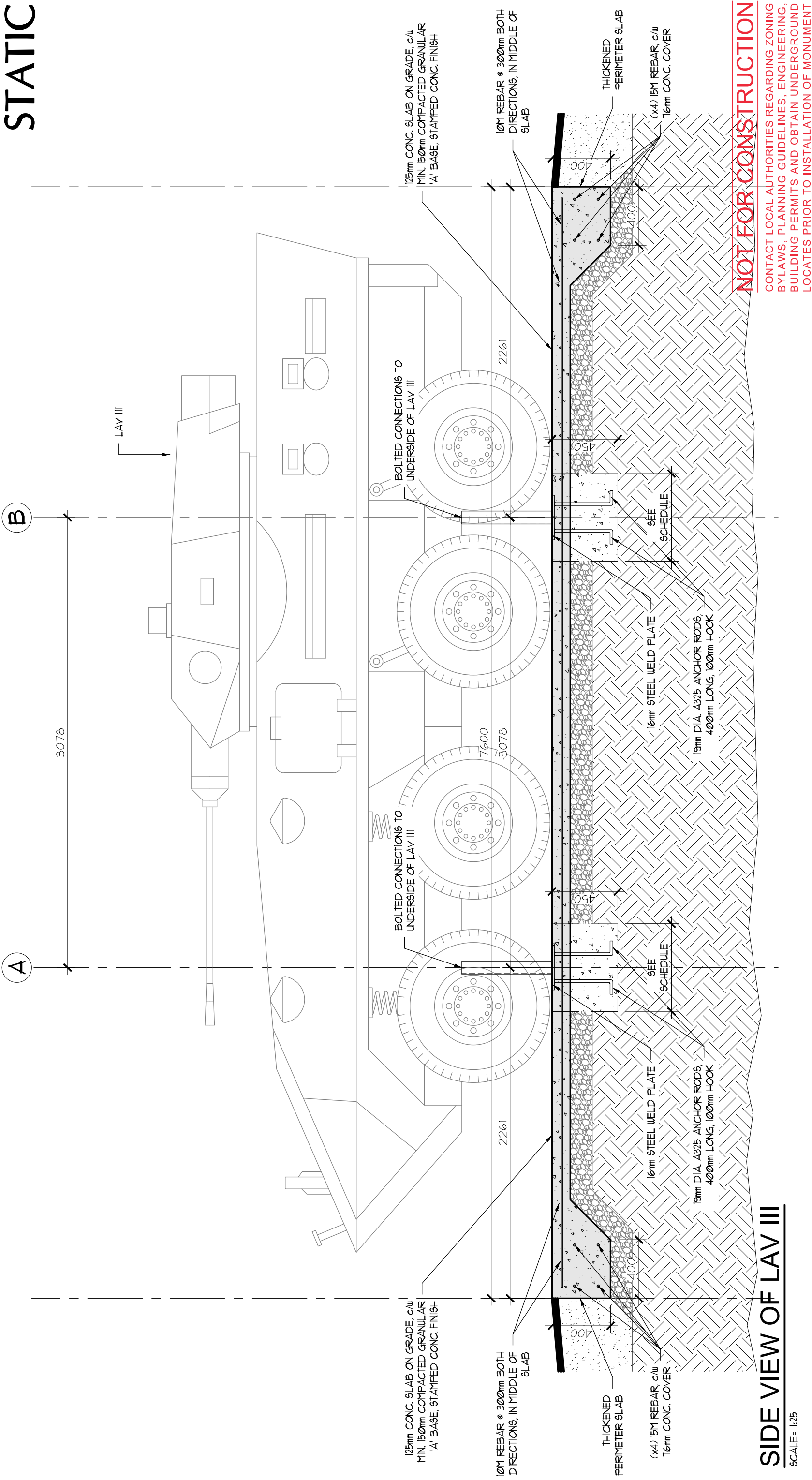

SIDE VIEW OF LAV III

SCALE= 1:25



**LAV III MONUMENT**  
**SIDE ELEVATION / SECTION DETAIL**

DWG:

**5 of 7**

REV:1 DATE: MAY 2, 2016

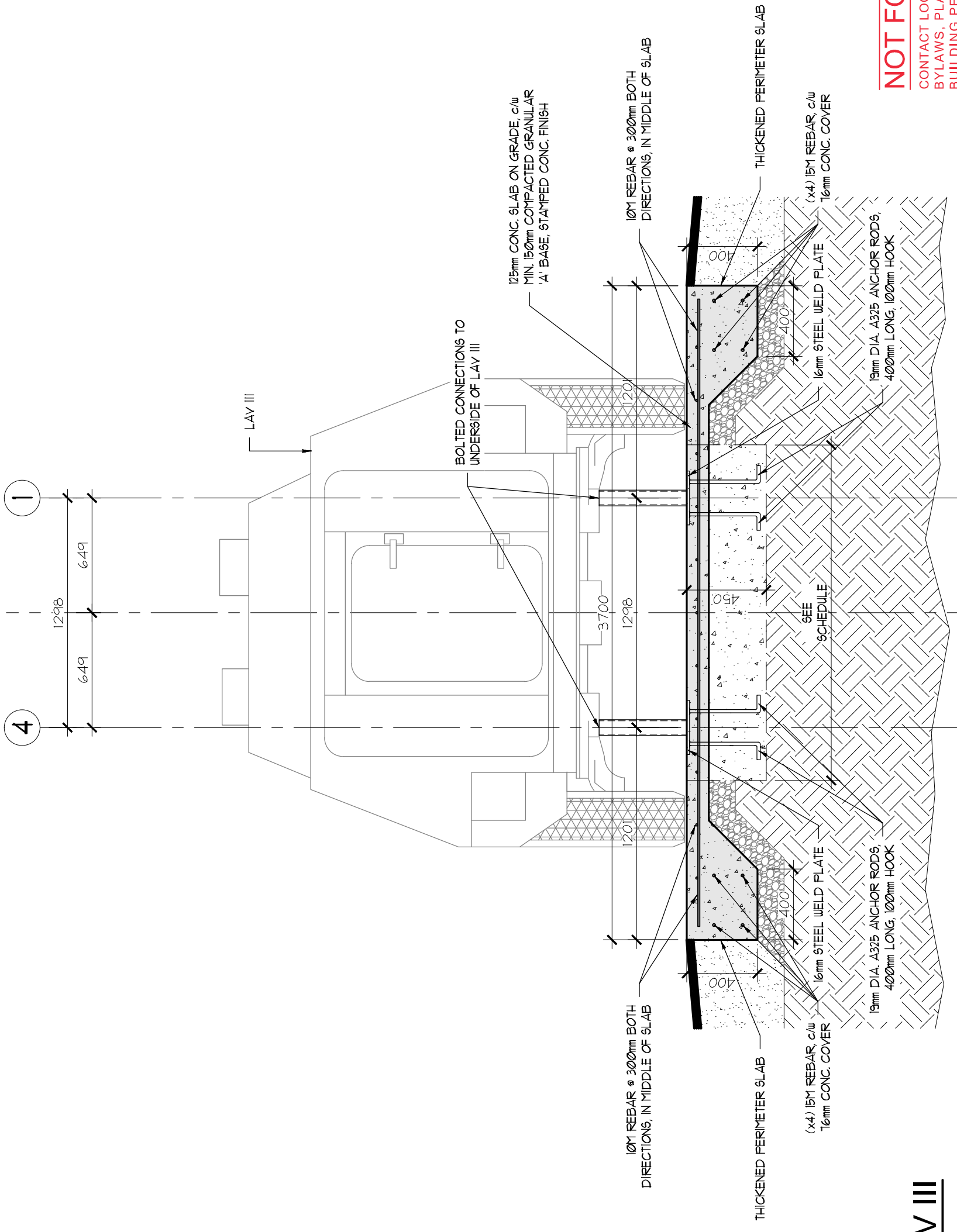

**NOT FOR CONSTRUCTION**  
CONTACT LOCAL AUTHORITIES REGARDING ZONING BYLAWS, PLANNING GUIDELINES, ENGINEERING, BUILDING PERMITS AND OBTAIN UNDERGROUND LOCATES PRIOR TO INSTALLATION OF MONUMENT

REAR VIEW OF LAV III  
SCALE= 1:25

# STATIC

LAV III Monument v2					
ITEMS	Quantity	Units	Unit Rate	Totals	Remarks
1000 psf Soil capacity					
Excavation	4	m3	\$ -	\$ -	
Backfill	4	m3	\$ -	\$ -	
Excavation Total	1	allow	\$ 2,000	\$ 2,000	min Charge
Armor Stone (v1 only)		tonne	\$ 220.00	\$ -	
Landscape Repair Allowance	1	allow	\$ 500.00	\$ 500	
Concrete Foundations	2	m3	\$ 450.00	\$ 900	
Foundation Rebar	45	kg	\$ 2.00	\$ 90	
Concrete Slab (v2 only)	28	m2	\$ 115.00	\$ 3,220	
Slab Rebar	300	kg	\$ 2.00	\$ 600	
Structural Stub Columns	4	each	\$ 500.00	\$ 2,000	
			\$ -	\$ -	
			\$ -	\$ -	
<b>Total Estimate (excl. H.S.T.)</b>				<b>\$9,310</b>	

LAV III Monument v2					
ITEMS	Quantity	Units	Unit Rate	Totals	Remarks
1500 psf Soil capacity					
Excavation	4	m3	\$ -	\$ -	
Backfill	4	m3	\$ -	\$ -	
Excavation Total	1	allow	\$ 2,000	\$ 2,000	min Charge
Armor Stone (v1 only)		tonne	\$ 220.00	\$ -	
Landscape Repair Allowance	1	allow	\$ 500.00	\$ 500	
Concrete Foundations	1.7	m3	\$ 450.00	\$ 765	
Foundation Rebar	35	kg	\$ 2.00	\$ 70	
Concrete Slab (v2 only)	28	m2	\$ 115.00	\$ 3,220	
Slab Rebar	300	kg	\$ 2.00	\$ 600	
Structural Stub Columns	4	each	\$ 500.00	\$ 2,000	
			\$ -	\$ -	
			\$ -	\$ -	
<b>Total Estimate (excl. H.S.T.)</b>				<b>\$9,155</b>	

LAV III Monument v2					
ITEMS	Quantity	Units	Unit Rate	Totals	Remarks
3000 psf Soil capacity					
Excavation	4	m3	\$ -	\$ -	
Backfill	4	m3	\$ -	\$ -	
Excavation Total	1	allow	\$ 2,000	\$ 2,000	min Charge
Armor Stone (v1 only)		tonne	\$ 220.00	\$ -	
Landscape Repair Allowance	1	allow	\$ 500.00	\$ 500	
Concrete Foundations	1.4	m3	\$ 450.00	\$ 630	
Foundation Rebar	30	kg	\$ 2.00	\$ 60	
Concrete Slab (v2 only)	28	m2	\$ 115.00	\$ 3,220	
Slab Rebar	300	kg	\$ 2.00	\$ 600	
Structural Stub Columns	4	each	\$ 500.00	\$ 2,000	
			\$ -	\$ -	
			\$ -	\$ -	
<b>Total Estimate (excl. H.S.T.)</b>				<b>\$9,010</b>	

## COST ESTIMATE

BASED ON DIFFERENT SOIL BEARING CAPACITIES



www.witzeldyce.com

# LAV III MONUMENT

## COST ESTIMATE

DWG:

# 7 of 7

REV:1 DATE: MAY 2, 2016

**NOT FOR CONSTRUCTION**

CONTACT LOCAL AUTHORITIES REGARDING ZONING BYLAWS, PLANNING GUIDELINES, ENGINEERING, BUILDING PERMITS AND OBTAIN UNDERGROUND LOCATES PRIOR TO INSTALLATION OF MONUMENT

1

2

3

4

B

B

A

A

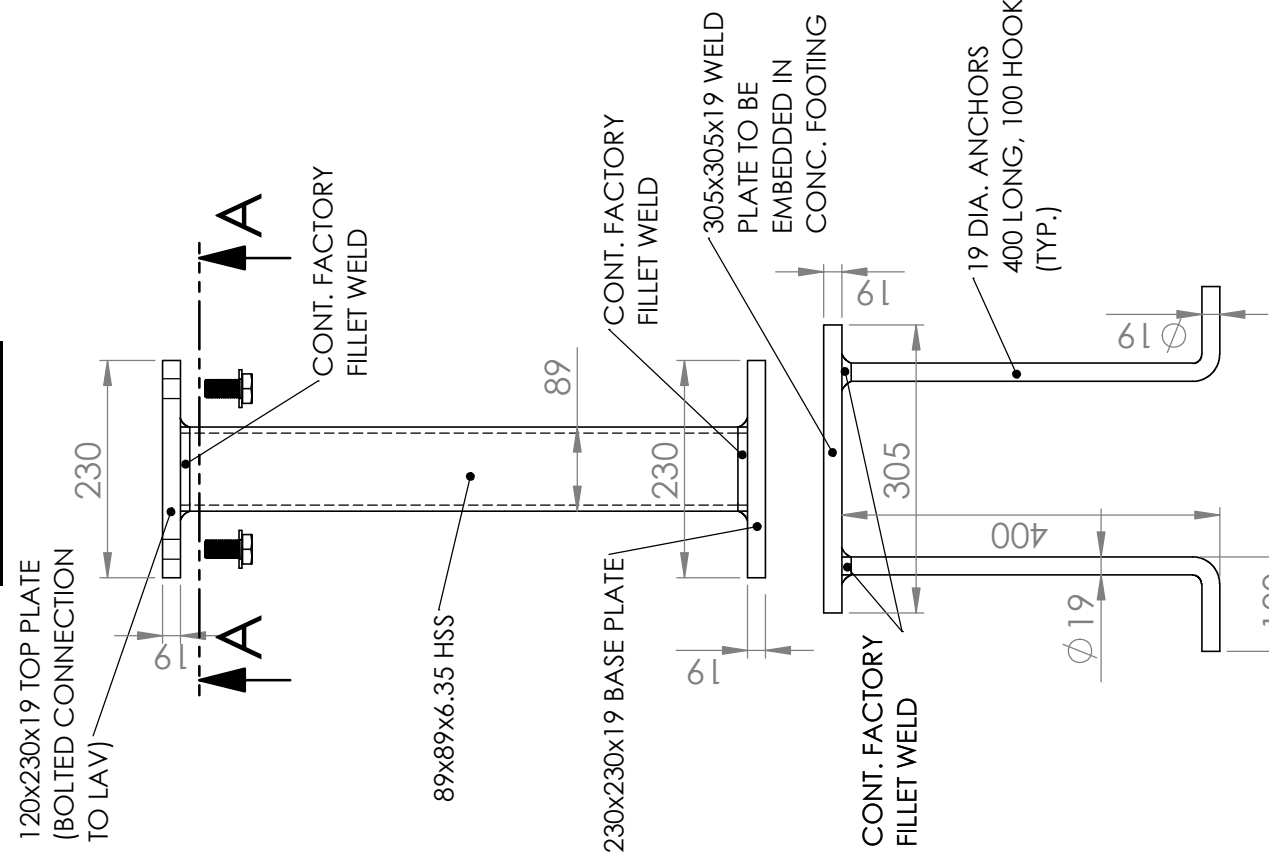
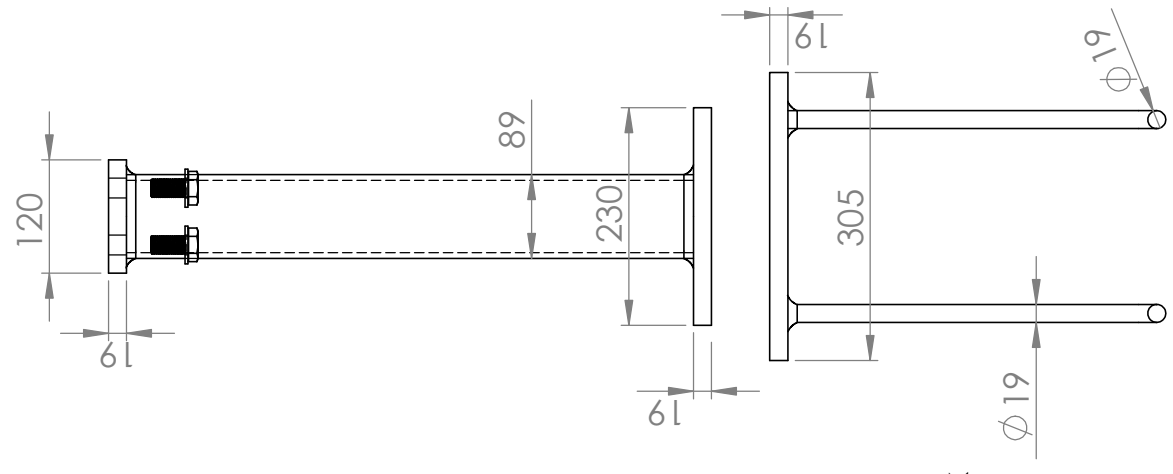
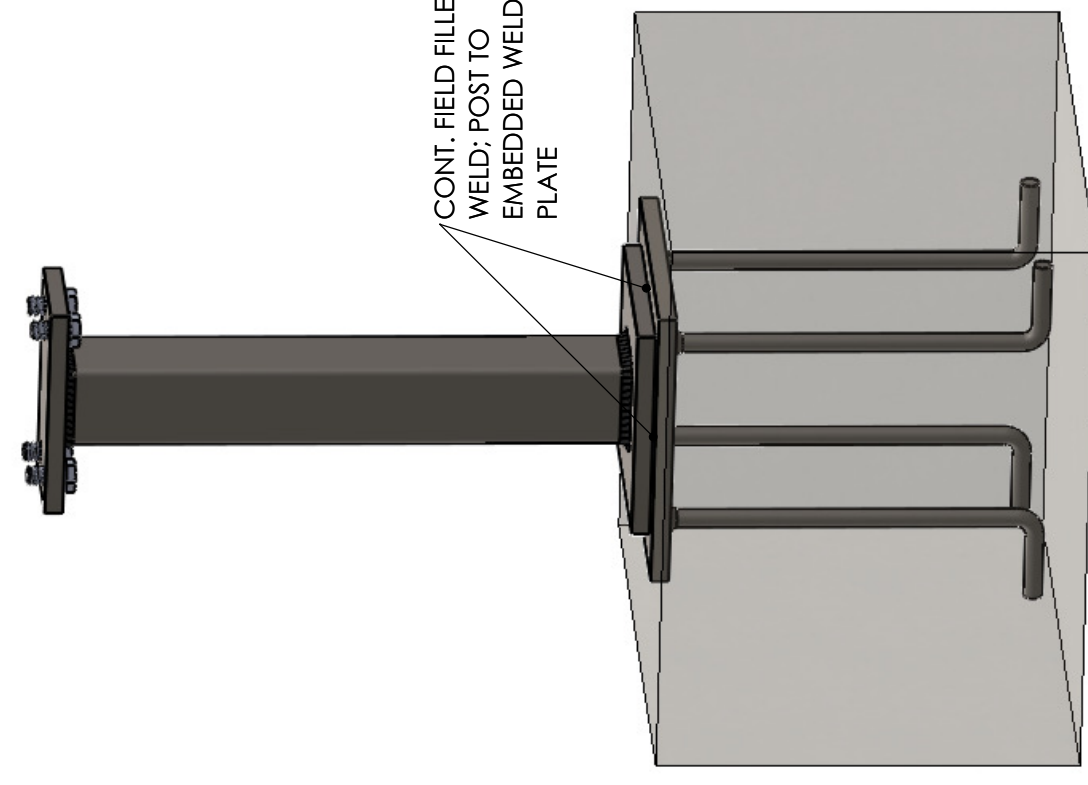
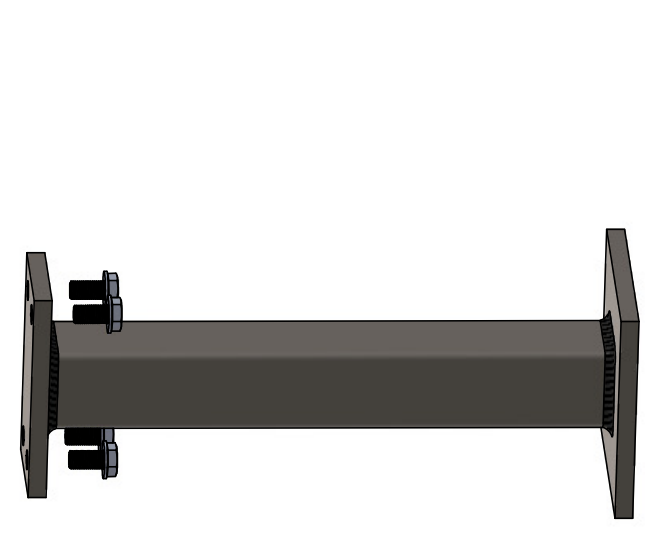
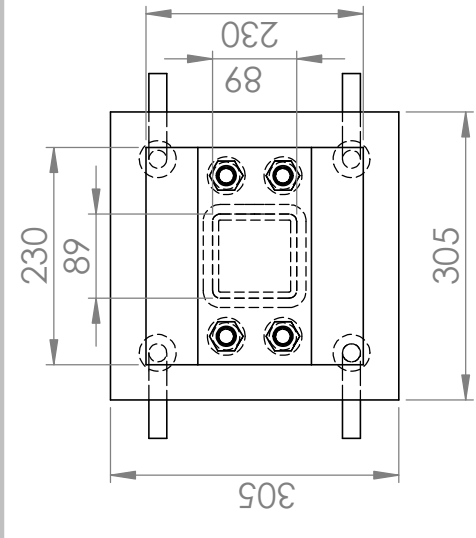
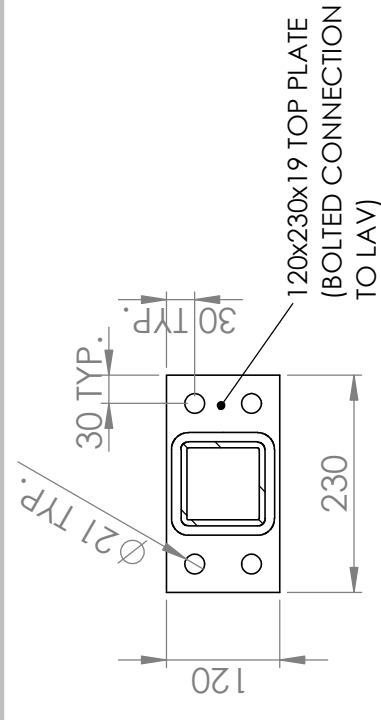

NAME	DATE
DRAWN	
CHECKED	
ENG APPR.	
MFG APPR.	
Q.A.	
COMMENTS:	

TITLE: LAV III MONUMENT

SIZE DWG. NO. **B** POST & WELD PLATE DETAILS REV

SCALE: 1:8 WEIGHT: SHEET 1 OF 1

1

2

3

4



**SCHEDULE D**

**Nontransfer and Use Certificate - DSP-83**

[see following page(s)]

## INSTRUCTIONS FOR DSP-83

The U.S. Department of State requires that this completed form DSP-83 be included as a part of an application for authorization to export significant military equipment and classified equipment or data (22 CFR §§123.10(a), 124.10 and 125.7.) Failure to submit will result in the application being returned without action. The form DSP-83 must be completed by the appropriate foreign persons (e.g., consignee, end-user, government) and forwarded to the U.S. Department of State through the U.S. person making the application.

1. *Item 1.* The U.S. Department of State will enter the application number when the form DSP-83 is submitted with the application. The U.S. applicant must provide the application number when form DSP-83 is submitted separately from the application.
2. *Item 2.* Show the name of the U.S. person submitting the application to the U.S. Department of State.
3. *Item 3.* Show the foreign person that will receive the articles/data for end-use. A bank, freight forwarding agent, or other intermediary is not acceptable as an end-user.
4. *Item 4.* Show the country in which the articles/data will ultimately receive end-use.
5. *Item 5.* Show precise quantities of the articles/data. List each article/data clearly, giving type, model number, make and (if known) U.S. military designation or national stock number. When components and spare parts are involved, fully identify the minor component, major component and end item in which they will be used (e.g., turbine blades for C-34 jet engine for F24B aircraft). Give a separate value for each major component. Values must represent only the selling price and not include supplementary costs such as packing and freight.
6. *Item 6.* To be completed by the foreign person who has entered into the export transaction with the applicant to purchase the articles/data for delivery to the end-user. This item shall be completed only if the foreign consignee is not the same as the foreign end-user.
7. *Item 7.* To be completed by the foreign person, in the country of ultimate designation, who will make final use of the articles/data.
8. *Item 8.* When requested by the U.S. Department of State, this item is to be completed by an official of the country of ultimate destination having the authority to so commit the government of that country.
9. *Item 9.* Certification of U.S. applicant.

\*This collection of information is voluntary. Public reporting burden for this collection of information is estimated to average 60 minutes per response, including time required for searching existing data sources, gathering the necessary documentation, providing the information and/or documents required, and reviewing the final collection. You do not have to supply this information unless this collection displays a currently valid OMB control number. If you have comments on the accuracy of this burden estimate and/or recommendations for reducing it, please send them to: Department of State, 2401 E St. NW, 12th Floor, Washington, D.C. 20037.



U.S. Department of State  
**UNITED STATES OF AMERICA**  
**NONTRANSFER AND USE CERTIFICATE**

1. This certificate is submitted in connection with export application no. \_\_\_\_\_

OMB No. 1405 0021  
EXPIRATION DATE: 09-30-2008  
\*ESTIMATED BURDEN: 1 Hour  
(Instruction Page)

2. Name of United States applicant	3. Name of foreign end-user C r C d	4. Country of ultimate destination <b>CANADA</b>
------------------------------------	---	---

5. Articles/data  
We certify that we have placed an order with the person named in item 2 for the following articles/data in the quantity and value shown below:

QUANTITY	ARTICLES/DATA DESCRIPTION	VALUE (U.S. \$)
1	Replicated Light Armoured Vehicle (LAV) III Monument  Decommissioned, extensively demilitarized in accordance with instruction provided by the Government of Canada and includes sub assemblies as outlined within the original nontransfer certificate signed by Militex Coatings Inc.	\$ 11,450.00

6. Certification of foreign consignee  
We certify that we are importing the articles/data listed in item 5 for delivery to the end-user in item 3. Except as specifically authorized by prior written approval of the U.S. Department of State, we will not re-export, resell, or otherwise dispose of any of those articles/data (1) outside the country in item 4 above, or (2) to any person, including the end-user, if there is reason to believe that it will result, directly or indirectly, in disposition of the articles/data contrary to the representations made in this certificate by any party. We further certify that all of the facts contained in this certificate are true and correct to the best of our knowledge and belief and we do not know of any additional facts that are inconsistent with this certificate. We will promptly send a supplemental certificate to the U.S. applicant in item 2 disclosing any change of facts or intentions set forth in this statement.

Sign here in ink \_\_\_\_\_  
Signature of Official, Foreign Consignee

\_\_\_\_\_ Date Signed (mm-dd-yyyy)

Type or print \_\_\_\_\_ Seal

Name and Title of Signer

7. Certification of foreign end-user  
We certify that we are the end-user of the articles/data in item 5. Except as specifically authorized by prior written approval of the U.S. Department of State, we will not re-export, resell, or otherwise dispose of any of those articles/data (1) outside the country in item 4 above, or (2) to any other person. If the end-user is a foreign government, we certify that we will observe the assurances contained in item 8. We further certify that all of the facts contained in this certificate are true and correct to the best of our knowledge and belief and we do not know of any additional facts that are inconsistent with this certificate.

Sign here in ink \_\_\_\_\_  
Signature of Official, End-User

\_\_\_\_\_ Date Signed (mm-dd-yyyy)

Type or print \_\_\_\_\_ Seal

Name and Title of Signer

8. Certification of foreign government  
We certify that we will not authorize the re-export, resales or other disposition of the articles/data authorized in item 5 outside the country in item 4 without prior written approval of the U.S. Government. If the articles/data are for use by our "armed forces" (i.e., army, navy, marine, air force, coast guard, national guard, national police, and any military unit or military personnel organized under or assigned to an international organization), we certify that we will use the authorized articles/data only: (a) for the purposes specified in the Mutual Defense Assistance Agreement, if any, between the U.S. Government and this government; (b) for the purposes specified in any bilateral or regional defense treaty to which the U.S. Government and this government are both parties, if subparagraph (a) is inapplicable; or (c) for internal security, individual self-defense, and/or civic action, if subparagraphs (a) and (b) are inapplicable.

Sign here in ink \_\_\_\_\_  
Signature of Government Official

\_\_\_\_\_ Date Signed (mm-dd-yyyy)

Type or print \_\_\_\_\_ Seal

Name and Title of Signer

9. We certify that no corrections, additions or alterations were made on this form by us after it was signed by the foreign consignee, foreign end-user or foreign government.

Sign here in ink \_\_\_\_\_  
Signature of Applicant

\_\_\_\_\_ Date Signed (mm-dd-yyyy)

Type or print \_\_\_\_\_ Seal

Name and Title of Signer

**SCHEDULE E**

**Supporting Groups and Organizations**

***To Whom It May Concern***

Reference: LAVIII Monument at Wolseley Barracks

Date: 28 February 2016

The Royal Canadian Regiment Museum is deeply interested in working with the City of London and London Heritage Council towards acquiring and presenting the LAV III equipment, decommissioned and re-furbished to static display shape. The museum fully endorses the City Culture Office efforts to forward an application to Canada Company for obtaining the LAVIII.

The museum already possesses vehicles and equipment in use with the Canadian Army since the Second World War; some are part of the museum main galleries, but 8 of them form a small outdoors display section (six of them in the landscaped garden situated north of The Royal Canadian Regiment Cenotaph at Wolseley Barracks and 2 on each side of the said Cenotaph). All of these items are included in our public programming, mostly the education program created by the museum. A LAVIII would be a most desirable addition as it allows to exploring Canadian Peacekeeping missions (former Yugoslavia, Ethiopia and Eritrea) as well as the conflict in Afghanistan.

Our history of partnership with London Heritage Council and the City of London is consistent with the museum's community engagement strategic orientation. Since 2012 we have participated in all programs administered by LHC (Museum School, London Doors Open, and annual London Heritage Fair). Thousands of students and general public from London have since discovered our newly renovated facility, our vast collection including a large variety of artefacts, our expanded permanent gallery and our customer friendly gift shop.

The Royal Canadian Regiment Museum, as a component of The Royal Canadian Regiment, preserves, collects and presents artefacts, archives and other militaria that are relevant for the history of the Regiment in order to assist in building pride, esprit and solidarity amongst all members of The RCR family. The Museum is also fostering a deeper understanding of the Regimental experience, within the broader context of military and Canadian history, among other veterans, communities in the London area and all Canadians.

Should you have any further questions and/or concerns regarding the LAVIII Monument at Wolseley Barracks, please do not hesitate to contact me.

Sincerely,



Georgiana Stanciu, PhD  
Executive Director

## APPENDIX B

Bill No.  
2017

By-law No.

A by-law to approve the License Agreement between Her Majesty the Queen in Right of Canada as represented by the Minister of National Defense and The Corporation of the City of London; and to authorize the Mayor and the City Clerk to execute the Agreement.

WHEREAS subsection 5(3) of the *Municipal Act, 2001*, S.O. 2001, c. 25, as amended, provides that a municipal power shall be exercised by by-law;

NOW THEREFORE the Municipal Council of The Corporation of the City of London enacts as follows:

1. The License Agreement attached as Schedule "A" to this by-law between Her Majesty the Queen in Right of Canada as represented by the Minister of National Defense and The Corporation of the City of London permitting the City to use a portion of property located at Wolseley Barracks for the purpose of installation of a permanent LAV III Monument is approved.
2. The Mayor and the City Clerk are authorized to execute the License Agreement approved under section 1 above.
3. This by-law shall come into force and effect on the day it is passed.

PASSED in Open Council \_\_\_\_\_, 2017.

Matt Brown  
Mayor

Catharine Saunders  
City Clerk

First reading -  
Second reading -  
Third reading -

**THIS AGREEMENT** made the \_\_\_\_ day of \_\_\_\_\_ 2017

**LICENSE AGREEMENT**

BETWEEN:

**HER MAJESTY THE QUEEN IN RIGHT OF CANADA (“Her Majesty”)**,  
as represented by the Minister of National Defence (“the Licensor”)

AND

**THE CORPORATION OF THE CITY OF LONDON**

300 Dufferin Avenue, PO Box 5035

London, ON

N6A 4L9

(the “Licensee”)

**WHEREAS** the **LICENSOR** is the owner of a property located at Wolseley Barracks 701 Oxford Street East, London ON (the “Premises”);

**AND WHEREAS** the **LICENSEE** has requested permission from the Licensor to use a portion of the Premises for the purpose of installation of permanent LAV III Monument on the North Side of Wolseley Barracks, near Royal Canadian Museum entrance, parade square and Cenotaph, in the outdoor display area (the “Monument”);

**AND WHEREAS** the **LICENSOR** has agreed to permit the Licensee to use a portion of the Premises for the installation of the Monument;

**NOW THEREFORE** this Agreement witnesses that in consideration of, and subject to, the terms and conditions set out herein, and for other good and valuable consideration (the receipt and sufficiency of which are hereby acknowledged) the parties hereby agree as follows:

**TERM**

1. The term of this Agreement shall be for a period of five (5) years commencing on the \_\_ day of June 2017 and terminating on the \_\_\_\_ day of 2022.
2. Subject to the provisions of this Agreement and provided that the Licensee is not in default hereunder, the Licensee shall, upon two (2) months prior written notice, have the option to extend the term of this Agreement for two (2) further terms of five (5) years each, with the same terms and conditions herein contained or as then amended by the parties hereto but in any event such renewed Agreement shall not require the Licensee to pay any fee, levy or charge for any extended term.

**USE OF PROPERTY**

3. The **LICENSOR** hereby grants to the **LICENSEE** a non-exclusive, non-transferable right, subject to the restrictions contained herein, to the area of the Premises outlined on Schedule “A” attached hereto (the “Licensed Area”).

**LICENSE FEE**

4. As consideration for the use of the Licensed Area, the Licensee shall pay to the Licensor the sum of \$1.00 of lawful money of Canada hereby deemed to have been given and received.

## LICENSEE'S COVENANTS

5.□ The Licensee covenants with the Licensor as follows:

- a.□ To use the Licensed Area only for the purpose of installation the Monument;
- b.□ To settle any claims against the Licensor as a result of the Monument for use on the Property during the term of this Agreement;
- c.□ Be responsible for all maintenance directly associated with its use of the Licensed Area and the Monument;
- d.□ To safeguard, maintain and restore during periods of construction, maintenance, repair, operation, replacement or removal of the Monument, all existing utility services used by the Licensor upon the Premises including, but not limited to, water, sewer, fire alarm, hydro and telephone services;
- e.□ To comply with all applicable federal, provincial and municipal laws, rules, regulations and by-laws and will hold the Licensor harmless from the consequences of its failure to do so;
- f.□ To abide by all applicable orders, instructions and regulations issued by or under the authority of the Licensor;
- g.□ To pay all rates, taxes, and payments in lieu thereof that may at any time during the existence of this Licence Agreement be lawfully imposed or become due and payable upon or in respect of the Licensed Premises;
- h.□ Not to create any waste;
- i.□ In the event that a deleterious substance or contaminant is discharged by the Licensee during the use of the Licensed Area, then the Licensee shall and it does hereby undertake and agree to take such remedial, restorative or reconstructive measures as may be necessary to retrieve and remove the deleterious substance or the contaminant and to restore the Licensed Area or any other part of the Premises thereby contaminated as a result of the discharge, to its former state, all at the sole cost and expense of the Licensee and in full compliance with any and all regulatory authorities; and,
- j.□ Be responsible for providing the engineering drawings and/or scope of work to and receive approval from THE LICENSOR prior to installation of the Monument for approval of methods and material to be used for construction of the concrete pad, lighting, material used to weatherproof the Monument, landscape plans and wording on proposed plaques.

## GENERAL

6.□ The Licensee acknowledges that this Agreement is granted for the sole purpose of allowing the Licensee use of the Licensed Area to erect the Monument.

## LIABILITY AND INDEMNIFICATION

- 7.□ The Licensee shall at all times indemnify and save harmless the Licensor from and against any and all claims, demands, losses, costs, charges, expenses, actions and other proceedings made, brought against, suffered by or imposed on the Licensor or its property in respect of any failure by the Licensee to fulfill any of its obligations under this License Agreement or for any reason whatsoever or in respect of any loss, damage or injury (including injury resulting in death) to any person or property (including, without restricting the generality of the foregoing, employees, contractors, agents and property of the Licensor) directly or indirectly arising out of, resulting from or sustained by reason of the occupation or use of the Licensed Area, or any operation in connection therewith or any fixture or chattels thereon.
- 8.□ The Licensor shall not be liable, directly or indirectly, for any personal injuries that may be suffered or sustained by any person who may be on the Licensed Area or for any loss of or damage or injury to property belonging to the Licensee or any other person unless such injury, loss or damage is due to THE LICENSOR's negligence or default or the negligence or default of those for whom THE LICENSOR is in law responsible.



9. □ The Licensee shall provide and maintain commercial general liability insurance in the minimum amount of two million dollars (\$2,000,000.00) per occurrence with respect to its use of the Licensed Area during the full term of this Agreement and extensions or renewals thereof, naming THE LICENSOR as an additional insured and to provide a certificate evidencing same, prior to execution of this Agreement and as required by THE LICENSOR. Without limiting the generality of the foregoing, such public liability insurance shall contain provision for cross-liability, severability of interest, and to provide thirty (30) days written notice of cancellation, termination or alteration of such policy to THE LICENSOR.
10. □ The termination of the term by expiry or otherwise shall not affect the liability of either party to the other with respect to any obligation under this Licence Agreement which has accrued up to the date of such termination but not been properly satisfied or discharged.

## RIGHT OF TERMINATION

11. □ Either party may terminate this License Agreement upon giving the other party at least ninety (90) days prior written notice, subject to the Licensor's right to terminate the agreement forthwith and without advance notice in the event of the Licensed Area being required for public purposes by reason of circumstance that, in the opinion of the Minister, constitute an emergency. In the event of early termination, the Licensor shall refund pro-rata the portion of rent, if any, accruing due after the date of said termination and the parties shall be released from any further obligations with respect to any matter under this License.
12. □ The termination of the Term or any renewal term by expiry or otherwise shall not affect the liability of either party to the other with respect to any obligation under this License Agreement which has accrued up to the date of such termination but has not then been properly satisfied or discharged.
13. □ Upon termination or expiration of this Licence Agreement, the Licensee shall remove all structures, equipment and things attached thereon erected (the "Restoration Work") on the Licensed Area and restore the Licensed Area to substantially the same condition at the expiry or termination of this Licence Agreement as it was at the commencement of this Licence Agreement. Prior to the commencement of the Restoration Work, the Licensee shall provide a work plan to THE LICENSOR outlining how the Restoration Work will be undertaken and the proposed timeline for completion. If the Licensee fails to perform the Restoration Work within ninety (90) days of expiry or earlier termination of this Licence Agreement, THE LICENSOR may carry out such activity as is necessary to restore the site and the Licensee shall reimburse THE LICENSOR for all costs incurred as a result of such restoration.

## NOTICE

14. □ All notices, payments, consents, demands, or other documents required or which may be given under this Licence Agreement, shall be in writing, duly signed by the party giving such notice and delivered or transmitted by registered or certified mail, email or telecopier (with confirmation of transmission) to a receiver at the addresses below:

In the case of the Licensor:

Department of National Defence  
Denison Armoury  
1 Yukon Lane  
Toronto, ON  
Attn: Judy Collins, Property Officer

Or such other address as the Licensor may advise in writing.

In the case of the Licensee:

City of London  
City Managers Officer  
300 Dufferin Avenue, PO Box 5035  
London, ON  
N6A 4L9  
Attn: Robin Armistead, Manager of Culture

Or such other address as the Licensee may advise in writing.

□

15. □ A faxed or emailed notice will be deemed to be received on the date of the fax or email if received before 4 p.m. or on the next business day if received after 4 p.m., or in the case of mailing, 5 business days after it is delivered to the post office. The designation of the person to be so notified or the address of such person may be changed at any time by either party by written notice.

**ENTIRE AGREEMENT**

16. □ This Licence Agreement constitutes the entire agreement between the parties and it can be amended or supplemented only by a written agreement signed by the parties.

**GOVERNING LAW**

17. □ This Licence Agreement is to be interpreted in accordance with the laws in force in the Province of Ontario, subject always to any paramount or applicable federal laws. Nothing in this Licence Agreement is intended to or is construed as limiting, waiving or derogating from any federal Crown prerogative.

**HOUSE OF COMMONS**

18. □ Members of the House of Commons and Senate shall not be entitled to share any part of this Licence Agreement or to any benefit arising therefrom.

**SUCCESSORS AND ASSIGNS**

19. □ This Licence Agreement shall ensure to the benefit of, and be binding upon the parties and their respective successors.

**COUNTERPARTS**

20. □ This Agreement may be signed by two or more counterparts, any one of which need not contain the signature of more than one party, but all such counterparts taken together will constitute one and the same agreement.

**IN WITNESS WHEREOF** this agreement has been executed by Her Majesty the Queen in Right of Canada, as represented by the Minister of National Defence, this \_\_\_ day of June 2017.

SIGNED, SEALED AND DELIVERED in the presence of

**FEDERAL REAL PROPERTY AUTHORITY, PURSUANT TO THE *Federal Real Property and Federal Immovables Act***

\_\_\_\_\_  
Judy Collins  
Property Officer,  
RP Operations Unit (Toronto)

Per: \_\_\_\_\_  
Major Dennis Slusar  
Officer Commanding  
RP Operations Unit (Toronto)

SIGNED, SEALED AND DELIVERED in the presence of

**HER MAJESTY THE QUEEN IN RIGHT OF CANADA, AS REPRESENTED BY THE MINISTER OF NATIONAL DEFENCE**

\_\_\_\_\_  
Witness:

Per: \_\_\_\_\_  
Col M. Misener  
Commander 4CDSG

SIGNED, SEALED AND DELIVERED

**THE LICENSEE, AS REPRESENTED BY THE CORPORATION OF THE CITY OF LONDON**

In the presence of  
\_\_\_\_\_  
Witness:

Per: \_\_\_\_\_  
Matt Brown, Mayor

Per: \_\_\_\_\_  
Catharine Saunders, City Clerk

### SCHEDULE "A"

- 
- 

#### Proposed Project

The LAV III Monument display would be located on the north side of Wolseley Barracks, near The Royal Canadian Museum entrance, Parade Square and Cenotaph, in the outdoors display area:



Proposed Location for  
LAV III Monument





National Défense  
Defence nationale

4<sup>th</sup> Canadian Division Support Group

Groupe de soutien de la 4<sup>e</sup> Division du Canada

Garrison Petawawa  
P.O. Box 9999 Stn Main  
Petawawa, Ontario K8H 2X3

Garrison Petawawa  
CP 9999 Succ Main  
Petawawa, Ontario K8H 2X3

7800-1 (OC ESS Toronto)

3 February 2016

Mrs. Robin Armistead  
Manager of Culture, City of London  
300 Dufferin Avenue, P.O. Box 5035  
London, ON N6A 4L9

LAV III MONUMENT PROGRAM -  
WOLSELEY BARRACKS

References: A. LAV III Monument Program letter, 18 December 2015  
B. LAV III Monument Program Proposal for Location at Wolseley Barracks

Dear Mrs. Armistead,

We received your cover letter and accompanying proposal for installing a LAV III Monument, to be provided by Canada Company as part of the LAV III Monument Program. My staff have reviewed the proposal for installing the monument at Wolseley Barracks, located at 701 Oxford Street East, London. At this time, I approve, in principle, your proposal so that you may submit your application to Canada Company's LAV III Monument Program to have a monument installed at Wolseley Barracks.

With the aim of ensuring that no ambiguity occurs between the City of London, London Heritage Council, and the Department of National Defence regarding the ownership and ongoing maintenance of the Monument, my staff will prepare a License Agreement and issue it to all involved parties for review and signature.

Should you require additional information, please feel free to contact Lieutenant-Colonel Don Saunders at (416) 633-6200 extension 5800 or don.saunders@forces.gc.ca.

Sincerely,

M. Gagné  
Colonel  
Commander

Canada

cc:

Mrs. Andrea Halwa  
Interim Executive Director, London Heritage Council  
251 Dundas Street  
London, ON N6A 6H9

Brigadier-General Lowell Thomas  
4 Canadian Division Headquarters  
1 Yukon Lane  
Toronto, ON M3K 0A1

Colonel Kevin Bertoia  
Commander  
31 Canadian Brigade Group Headquarters  
701 Oxford Street East  
London, ON N5Y 4T7