

Dingman Creek Erosion Control Wetland

- Construction completed 2015
- 21 hectares in size
- Formerly agricultural land

October 1, 2015



October 5, 2016



Table EX-3: Summary of the Wetland Habitat Features

Wetland Feature	Wetland Cells	
	Cell #1	Cell #2
Fish Passageways		
• Passageway Length (m)	1,330	490
• Passageway Slope (%)	0	0
• Passageway Outside Width (m)	5.0	5.0
• Passageway Inside Width (m)	4.4	4.4
• Biolog Diameter (m)	0.3	0.3
• Passageway Depth (m)	0.3	0.3
Dead Standing Timber		
Number of Dead Standing Timber Units	25	0
Floating Basking Logs		
Number of Floating Basking Log Units	16	0
Turtle Nesting Sites		
Number of Turtle Nesting Sites	5	0
Bird Boxes		
Number of Bird Boxes	0	15
Bat Boxes		
Number of Bat Boxes	7	0

Detail: Turtle Nesting Island

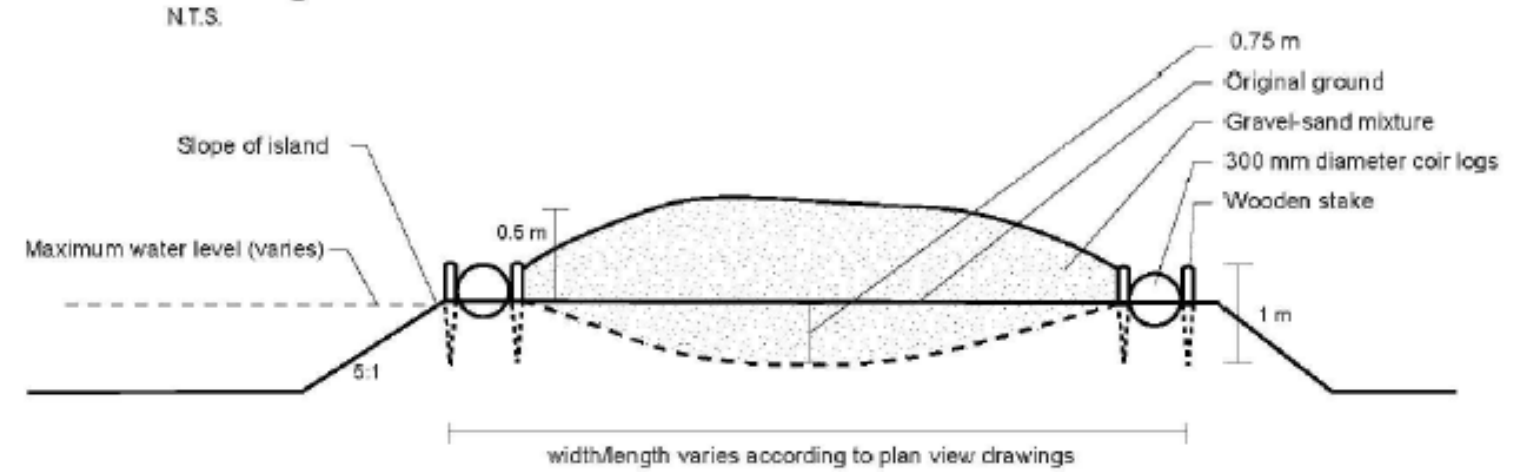

Detail: Standing Dead Tree

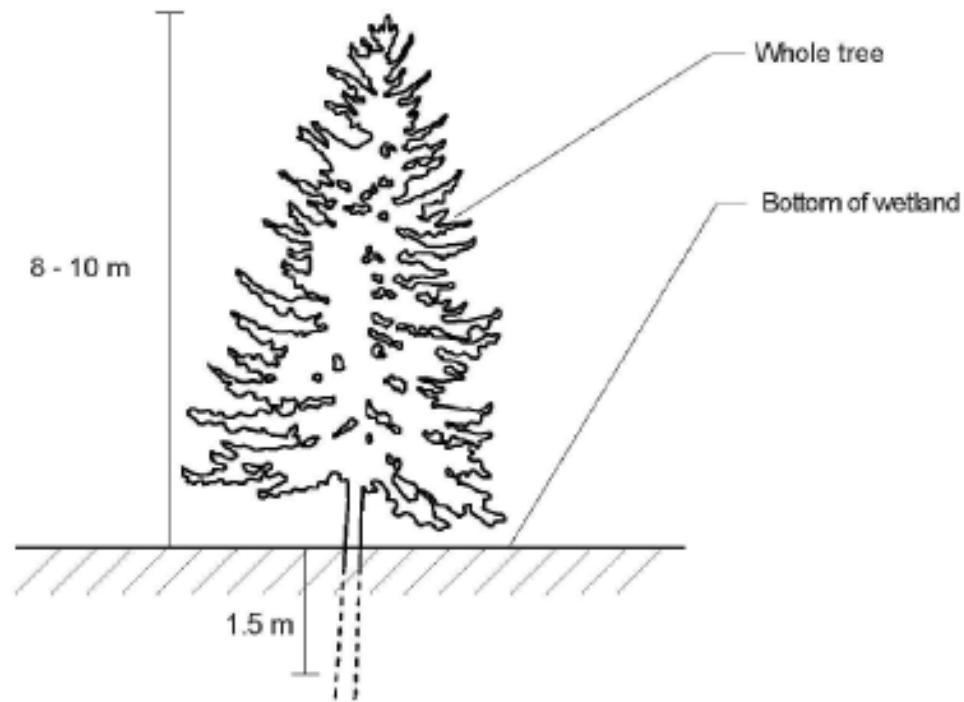

Detail: Floating Basking Log

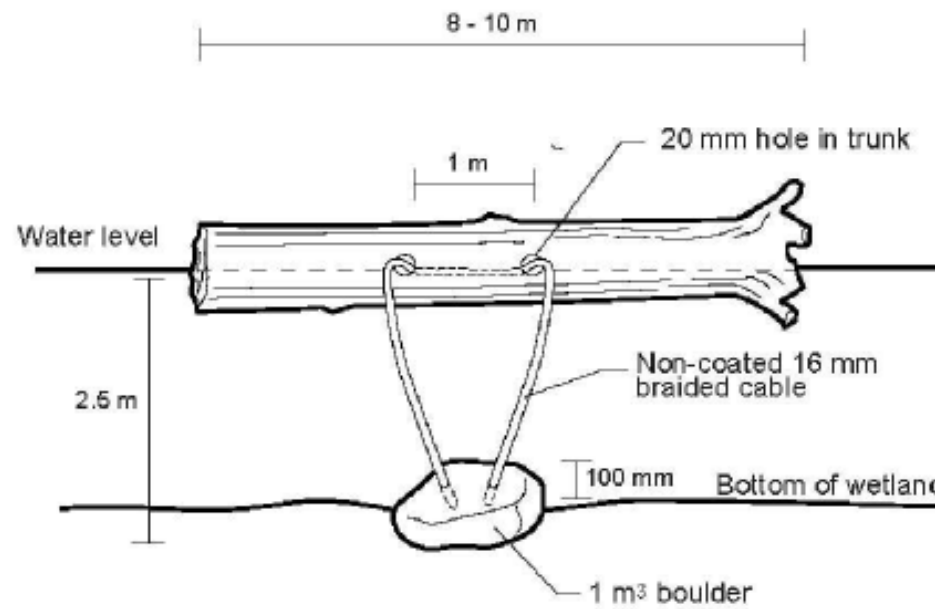

Cross Section: Drainage Channel

