

BANNISTER DRAIN 2016

City of London



**SPRIET
ASSOCIATES**

ENGINEERS & ARCHITECTS

155 York Street
London, Ontario N6A 1A8
Tel. (519) 672-4100
Fax (519) 433-9351
E-mail MAIL@SPRIET.ON.CA

Our Job No. 211205

May 30, 2016

London, Ontario
May 30, 2016

BANNISTER DRAIN 2016

City of London

To the Mayor and Council of
The City of London

Mayor and Council:

We are pleased to present our report on the reconstruction and expansion to portions of the Bannister Municipal Drain serving parts of Lots 19 to 22, Concessions 4 to 6 (Westminster), in the City of London.

AUTHORIZATION

This report was prepared pursuant to Sections 4 and 78 of the Drainage Act in accordance with instructions received from your Municipality with respect to a motion of Council.

The work on the existing portion and extension of Branch 1 was initiated by a petition signed by the City of London road authority. The construction of Branch 3 was initiated by a petition signed by a majority of the owners in the area requiring drainage.

DRAINAGE AREA

The total watershed area as described above contains approximately 199 Hectares. The area requiring drainage for Branch 3 is described as the east part of the north half of Lot 22 and the west part of the north half of Lot 21, Concession 5.

HISTORY

The portion of the Bannister Drain serving the area in question was last reconstructed pursuant to a report submitted by S.W. Archibald, O.L.S. dated January 25, 1950 and consisted of a Main Drain and two Branch Drains. The Main Drain extended from an outlet in the Dingman Creek in the north part of Lot 23, Concession 4, upstream southerly and easterly to its head in the north half of Lot 19, Concession 5. The area in question was partially served by a branch referred to as Branch 1.

A subsequent report for the Bannister Drain was submitted by J. P. McIntyre, P.Eng., dated October 1, 1984, which provided for the reassessment of the Main Drain.

EXISTING DRAINAGE CONDITIONS

A site meeting was held and a field investigation and survey were completed. Upon reviewing our findings, we note the following:

- that the City of London is experiencing poor drainage conditions along Westminster Drive in parts of Lots 21 and 22
- the City requested that an old existing private tile which extended from the top of Branch 1 easterly into the low areas in Lot 21 be replaced to provide proper drainage for their road allowance
- that the existing Branch 1 has been replaced at some time in the past with a 300mm clay tile which is shallow and undersized by today's standards
- that a private culvert has also been installed in the existing open ditch of the Main Drain at some time in the past
- that the invert of the existing culvert and subsequently the existing open ditch upstream in the area of Branch 1 is significantly shallow and does not provide a sufficient outlet for any replacement / improvement to Branch 1
- that the old 200mm to 125mm private clay tile serving the area in Lot 21 no longer functions and results in significant ponding of water in low lying 'trapped' pockets of land
- that the portion of this low lying land on the north side of Westminster Drive has been filled in by the landowner in the relative recent past
- that the original Bannister and subsequent downstream Bannister drainage reports show area to the south of the lands in question being trapped without a natural surface outlet
- that the above area is predominantly comprised of gravel soils and has several gravel pits throughout

At an informal public meeting to review the proposed work the two landowners immediately to the south of Westminster Drive, which are the lands where the proposed drain will be located, reported that other low lying 'trapped' pockets of land on their property, that are assessed to the Bannister Drain, were experiencing significant rise in ground water levels over time. They also reported that their properties are now being regularly flooded to the point where substantial areas of agricultural field remain under water permanently and trees in the wooded areas are dying off due to saturation.

It was also reported that this area was serviced by an old private tile drain westerly and northerly to the Bannister Drain at Highway 402, which is no longer functioning. As a result these owners submitted a petition under the Drainage Act to provide a new Branch Drain to provide some drainage for the affected area. Upon being instructed to include the new branch as part of this project we completed a survey and field investigation and note the following:

- that the area which would be directly tributary by surface water to the requested branch consists of 8.7 hectares of agricultural land and 4.3 hectares of wooded area

EXISTING DRAINAGE CONDITIONS (cont'd)

- that presently approximately 2.4 hectares of this area is under water whereas the owners reported that at one time none of this area was
- that through a hydro-geological report prepared for the gravel pits to the south it has been determined the source of this rise in ground water levels is substantially due to rebound as a result of production ceasing from the White Oak Municipal wells in 1967. Wells 1, 2, 3, and 5 were decommissioned in 2001 and wells 4 and 6 in 2004
- that the above hydro-geological report indicated that most of the ground water rebound had occurred by 2010 but some low bowl-shaped treed areas could have intensified and continued the ground water recharge
- that when comparing OBM information for the area from 2006, 2012 and 2014 it is clear that a significant rise in water levels has occurred
- that through review with the Upper Thames River Conservation Authority they indicated support some lowering of the current ground water in the area through drainage while also having regard to protect the natural and positive aspects that low lying wetlands provide
- that the area directly tributary to Branch 3 would be provided with the most drainage improvement while other low lying 'trapped' areas within the Branches watershed that are not directly connected and further away would see less improvement, reducing as the distance grows

DESIGN CRITERIA AND CONSIDERATIONS

The Drainage Coefficient method contained in the "DRAINAGE GUIDE FOR ONTARIO", Publication 29 by the Ontario Ministry of Agriculture, Food, and Rural Affairs is typically used to design municipal drains. The Drainage Coefficient defines a depth of water that can be removed in a 24 hour period and is expressed in millimetres per 24 hours. The coefficient used to design this drain with respect to capacity was 38mm per 24 hrs for the directly connected tributary areas. As some slow groundwater movement is expected from the areas to the south the area encompassing Highway 401 and north was designed at 10% of normal ratio and areas south of the 401 at 5%.

We would like to point out that there have been indications of unstable soil conditions in the low lying areas but no formal soil investigation has been made.

All of the proposed work has been generally designed and shall be constructed in accordance with the DESIGN AND CONSTRUCTION GUIDELINES FOR WORK UNDER THE DRAINAGE ACT.

RECOMMENDATIONS

We are therefore recommending the following:

MAIN DRAIN:

- that the ditch be reconstructed for 257 meters downstream and 103 meters upstream of Branch 1 to provide a proper sub-surface drainage outlet
- that excavated material be levelled adjacent to the drain
- that the ditch bottom and ditch slopes be cleared of any trees, brush and scrub
- that the working space and access route be cleared and grubbed of trees, brush and scrub where required for machines to access and complete the work on the ditch and the areas where excavated material is to be levelled
- that the stumps, logs and brush be piled beyond this width
- that a new farm culvert consisting of 1800mm pipe culvert be constructed on the Hydro One Networks Inc. property (Roll No. 030-080-154), including the removal and disposal of the existing culvert

BRANCH 1:

- that the existing Branch 1 be replaced with a new 600mm to 450mm concrete tile (including related appurtenances) and that the existing tile be abandoned from municipal status pursuant to Section 19 of the Drainage Act
- that Branch 1 be extended upstream with 400mm to 300mm tile (including related appurtenances) to provide a proper surface and sub-surface drainage outlet for Westminster Drive and adjacent lands
- that a new 457mm smooth wall steel pipe be bored under Westminster Drive and that the existing pipe be filled with grout

BRANCH 3:

- that a new tile branch drain be constructed from Branch 1 southerly to the low areas consisting of 350mm to 375mm concrete tile and sewer pipe
- that a catchbasin be installed at the property line halfway between the two lower areas with swales to be constructed both north and south to direct surface water to the new drain
- that the catchbasin inlet elevation at the top end of Branch 3 be set at an elevation of 257.90 which is a compromise between the 2014 water level of 258.95 and the 2006 water level of 257.17

RECOMMENDATIONS (cont'd)

Due to the indications of poor soil conditions our design includes the wrapping of tile joints with geotextile and a contingency allowance for crushed stone bedding wrapped with geotextile where and if necessary. These areas are typically identified at the time of construction but may only become apparent after construction is completed. In this case, the extra costs for removal and reinstallation on stone bedding would be an extra to the project and if already billed become a supplementary billing.

ENVIRONMENTAL CONSIDERATIONS AND MITIGATION MEASURES

Based on the information available, there are no provincially significant wetlands or endangered species within the affected watershed area or along the route of the drains. The proposed construction includes quarry stone outlet protection and seeding which will help stabilize disturbed areas.

We have reviewed the proposed work and have submitted the report to the UTRCA, DFO, and MNR (UTRCA) for review under their respective environmental legislations.

We are also recommending that the following erosion and sediment control measures be included as part of our reconstruction proposal to help mitigate any potential adverse impacts of the proposed drainage works on water quality and fishery habitat:

- timing of construction is to be only at times of low or no flow
- a temporary flow check of silt fencing is to be installed for the duration of the construction at the bottom end of the ditch reconstruction

SUMMARY OF PROPOSED WORK

The proposed work consists of approximately 360 lineal meters of open ditch reconstruction including quarry stone rip-rap bank protection, bank seeding, construction of a farm culvert; approximately 944 lineal meters of 600mm to 300mm concrete field tile and sewer pipe and 100 meters of grassed swale.

SCHEDULES

Three schedules are attached hereto and form part of this report, being Schedule 'A' - Allowances, Schedule 'B' - Cost Estimate, and Schedule 'C' - Assessment for Construction.

Schedule 'A' - Allowances. In accordance with Sections 29 and 30 of the Drainage Act, allowances are provided for right-of-way and damages to lands and crops along the route of the drain as defined below.

Schedule 'B' - Cost Estimate. This schedule provides for a detailed cost estimate of the proposed work which is in the amount of \$ 179,800.00. This estimate includes engineering and administrative costs associated with this project.

SCHEDULES (cont'd)

Schedule 'C' - Assessment for Construction. This schedule outlines the distribution of the total estimated cost of construction over the roads and lands which are involved.

Drawing No.'s 1 and 2, Job No. 211205, and specifications form part of this report. They show and describe in detail the location and extent of the work to be done and the lands which are affected.

ALLOWANCES

DAMAGES: Section 30 of the Drainage Act provides for the compensation to landowners along the drain for damages to lands and crops caused by the construction of the drain.

The amounts granted are based on the following:

- a) for closed drain - \$3,613.00/ha.
- b) for open ditch work with excavated material levelled adjacent to drain - \$4,647.00/ha.

These base rates are multiplied by the hectares derived from the working widths shown on the plans and the applicable lengths.

RIGHT-OF-WAY Section 29 of the Drainage Act provides for an allowance to the owners whose land must be used for the construction, repair, or future maintenance of a drainage works.

For tile drains where the owners will be able to continue to use the land, the allowance provides for the right to enter upon such lands, and at various times for the purpose of inspecting such drain, removing obstructions, and making repairs. Also, the allowance provides for the restrictions imposed on those lands to protect the right-of-way from obstruction or derogation. The amounts granted for right-of-way on tile drains is based on a percentage of the value of the land designated for future maintenance. Therefore, the amounts granted are based on \$6,670.00/ha. This value is multiplied by the hectares derived from the width granted for future maintenance and the applicable lengths. No right-of-way was previously provided for the existing municipal portion of the drain being replaced.

For open ditches, the allowance provides for the loss of land due to the construction provided for in the report. The amounts granted are based on the value of the land, and the rate used was \$33,360.00/ha.

ASSESSMENT DEFINITIONS

In accordance with the Drainage Act, lands that make use of a drainage works are liable for assessment for part of the cost of constructing and maintaining the system. These assessments are known as benefit, outlet liability and special benefit as set out under Sections 22 and 23 of the Act.

ASSESSMENT DEFINITIONS

SECTION 22

Benefit as defined in the Drainage Act means the advantages to any lands, roads, buildings or other structures from the construction, improvement, repair or maintenance of a drainage works such as will result in a higher market value or increased crop production or improved appearance or better control of surface water, or any other advantages relating to the betterment of lands, roads, buildings or other structures.

Special Benefit is assessed to lands for which some additional work or feature has been included in the construction repair or improvement of a drainage works. The costs of such work are separated and assessed independently from the regular work. Typically these assessments are not considered special benefits under Section 24.

SECTION 23

Outlet liability is assessed to lands or roads that may make use of a drainage works as an outlet either directly or indirectly through the medium of any other drainage works or of a swale, ravine, creek or watercourse.

In addition, a Public Utility or Road Authority shall be assessed for and pay all the increased cost to a drainage works due to the construction and operation of the Public Utility or Road Authority. This may be shown as either benefit or special assessment.

ASSESSMENT

A modified "Todgham Method" was used to calculate the assessments shown on Schedule 'C'- Assessment for Construction. This entailed breaking down the costs of the drain into sections along its route. Special Assessments and Special Benefits were then extracted from each section.

The remainder is then separated into Benefit and Outlet costs. The Benefit cost is distributed to those properties receiving benefit as defined under "Assessment Definitions", with such properties usually being located along or close to the route of the drain. The Outlet Costs are distributed to all properties within the watershed area of that section on an adjusted basis. The areas are adjusted for location along that section, and relative run-off rates. Due to their different relative run-off rates, forested lands have been assessed for outlet at lower rates than cleared lands. Also, roads and residential properties have been assessed for outlet at higher rates than cleared farm lands.

The actual cost of the work involving this report, with the exception of Special Assessments, is to be assessed on a pro-rata basis against the lands and roads liable for assessment for special benefit, benefit, and outlet as shown in detail below and on Schedule 'C' - Assessment for Construction. The Special Assessments shall be levied as noted in the Section "Special Assessment".

The cost to restore water supply for any well determined to be impacted by any construction covered under this report shall become part of this report and be pro-rated with the costs provided for in this report.

SPECIAL BENEFIT ASSESSMENTS

Special Benefit Assessments have been made against individual properties for their portion of the cost of various special works provided to them. These works typically include farm culverts and shall be as shown on Schedule 'C' - Assessment for Construction. For open drains the Contractor shall contact the owner and request that all known outlet pipes be marked by the owner prior to commencement of excavation on each property. All outlets so marked or visible or as noted on the profile, and subsequently damaged by the Contractor's operations, will be repaired by the Contractor at his cost. All other outlet pipes repaired by the Contractor under direction of the Drainage Superintendent or Engineer shall be considered an extra to the contract price. This cost shall be assessed to the property as a non-pro-rateable special benefit.

SPECIAL ASSESSMENT

In accordance with Section 26 of the Drainage Act, a Special Assessment has been made against the City of London being the increased cost to the drainage work for boring a 457mm smooth wall steel pipe across their road allowance on Branch 1, due to the construction and operation of Westminster Drive. The Special Assessments shall be made up of the actual cost of this work and both the final and estimated values of the Special Assessment are to be calculated as follows:

Drain Crossing	Cost of Work	Less Equivalent Drain Cost (Fixed)	Plus Administration Cost	Plus Interest & Net H.S.T.	Special Assessment
Branch 1	\$10,580.00	\$675.00	\$1,935.00	\$240.00	\$12,080.00

The above special assessments shall not apply for future maintenance purposes.

A further Special Assessment has been made against the Bannister Drain Main Drain-Open Portion for a portion of the culvert replacement and ditch work. The Special Assessment shall apply when pro-rating construction costs and shall be levied against upstream lands and roads assessed the 1984 report and in the same relative proportions.

If any additional work is required to the drainage works due to the existence of buried utilities such as gas pipe lines, communications cables, etc. or if any of the utilities require relocation or repair, then, the extra costs incurred shall be borne by the utility involved in accordance with the provisions of Section 26 of the Drainage Act.

GRANTS

In accordance with the provisions of Section 85 of the Drainage Act, a grant **may** be available for assessments against privately owned parcels of land which are used for agricultural purposes and eligible for the Farm Property Class Tax rate. Section 88 of the Drainage Act directs the Municipality to make application for this grant upon certification of completion of this drain. The Municipality will then deduct the grant from the assessments prior to collecting the final assessments.

MAINTENANCE

Upon completion of construction, all owners are hereby made aware of Sections 80 and 82 of the Drainage Act which forbid the obstruction of or damage or injury to a municipal drain.

After completion, the Main Drain shall be maintained by the City of London at the expense of all upstream lands and roads assessed in Schedule of Assessment in the 1984 report and in the same relative proportions until such time as the assessment is changed under the Drainage Act.

After completion, Branches 1 and 3 shall be maintained by the City of London at the expense of all upstream lands and roads assessed in Schedule 'C' - Assessment for Construction and in the same relative proportions, with the exception that Special Assessments and Special Benefits shall **not** be pro-rated for future maintenance purposes, until such time as the assessment is changed under the Drainage Act.

Repairs or improvements to any road culvert or sub-surface road crossing shall be the responsibility of the applicable Road Authority, entirely at their cost.

The new farm culvert on the property described by Roll No. 030-280-154 shall have future maintenance costs levied two-thirds to the affected owner and the remainder shall be pro-rated over the upstream outlet assessments in the 1984 report.

Respectfully submitted,

SPRIET ASSOCIATES LONDON LIMITED



M.P. DeVos, P. Eng.



MPD:bv

SCHEDULE 'A' - ALLOWANCES

BANNISTER DRAIN 2016

City of London

In accordance with Sections 29 and 30 of the Drainage Act, we determine the allowances payable to owners entitled thereto as follows:

CONCESSION	LOT	ROLL NUMBER (Owner)	Section 29 Right-of-Way	Section 30 Damages	TOTALS
BRANCH 1 (and Main Drain Deepening)					
<i>Geographic Westminster</i>					
5	Pt. N½ 21	080-040-084 (969726 Ontario Ltd.)	\$ 1,730.00	\$ 1,410.00	\$ 3,140.00
5	N½ 22	080-040-085 (Lobban Farms Ltd.)	1,050.00	1,060.00	2,110.00
4	Pt. E½S½ 22	080-040-097 (Cobrell Holdings Inc.)	2,180.00	3,060.00	5,240.00
Right-of-W		030-280-154(Hydro One Networks Inc.)	270.00	470.00	740.00
Total Allowances			\$ 5,230.00	\$ 6,000.00	\$ 11,230.00
TOTAL ALLOWANCES ON BRANCH 1 (and Main Drain Deepening)				\$ 11,230.00	
BRANCH 3					
<i>Geographic Westminster</i>					
5	N½ 22	080-040-085 (Lobban Farms Ltd.)	\$ 2,930.00	\$ 2,380.00	\$ 5,310.00
Total Allowances			\$ 2,930.00	\$ 2,380.00	\$ 5,310.00
TOTAL ALLOWANCES ON BRANCH 3				\$ 5,310.00	
TOTAL ALLOWANCES ON THE BANNISTER DRAIN 2016				\$ 16,540.00	

SCHEDULE 'B' - COST ESTIMATE

BANNISTER DRAIN 2016

City of London

We have made an estimate of the cost of the proposed work which is outlined in detail as follows:

BRANCH 1 (and Main Drain Deepening)

360 meters of open ditch reconstruction (Approx. 390 m ³)	\$	1,950.00
Seeding of ditch banks (approx. 1350 m ²)	\$	610.00
Levelling of excavated material	\$	1,000.00
Clearing & grubbing	\$	200.00
Supply & installation of the following helical corrugated aluminized steel pipe as new road culvert including supply and installation of quarry stone rip-rap protection around each end of pipe , removal & disposal of existing pipe culvert, supply & compaction of bedding and backfill materials, surface restoration		
13 m - 1800mm dia, 2.8mm thick, 125mm x 25mm cor. (12 m ³ q.s.)	Supply \$	5,160.00
Sta. 0+250 (Open Portion)	Installation \$	5,990.00
6.0 meters of 600mm dia., H.D.P.E. plastic sewer pipe including rodent gate		
Supply (Single Length)	\$	850.00
Supply and Install quarry stone rip-rap protection around pipe (Approximately 4m ³ quarry stone req'd)	\$	900.00
Installation of the following concrete field tile including supply & installation of geotextile around tile joints (approx. 800m req'd)		
337 meters of 300mm dia. concrete tile	\$	6,030.00
74 meters of 400mm dia. concrete tile	\$	1,550.00
23 meters of 450mm dia. concrete tile	\$	430.00
124 meters of 600mm dia. concrete tile	\$	2,600.00
Supply of the above listed tile	\$	13,190.00
Stripping, stockpiling topsoil and relevelling upon completion (4m width)	\$	3,500.00
Contingency amount for increased cost due to poor soil conditions:		
Installation of tile on crushed stone bedding with excavator (275 meters)	\$	6,900.00
Supply & delivery of 19mm crushed (Approx. 160 tonnes req'd)	\$	3,450.00
15.0 meters of 300mm sewer pipe		
Supply	\$	420.00
Installation under laneway by open cut	\$	2,630.00
15.0 meters of 457mm (18") dia. 6.3mm thickness smooth was steel pipe		
Supply	\$	2,630.00
Installation under Westminister Drive by boring	\$	6,300.00
Disconnect Existing 200mm subsurface road crossing and fill with cement grout	\$	1,650.00

SCHEDULE 'B' - COST ESTIMATE (cont'd)

BANNISTER DRAIN 2016
City of London**BRANCH 1 (and Main Drain Deepening) (Cont.)**

Supply and install one 200mm dia. "Hickenbottom" catchbasin and three 600mm x 600mm ditch inlet catchbasins, including grates, leads, ditching, removal and disposal of existing catchbasins	\$ 6,000.00
Exposing and locating existing tile drains	\$ 1,000.00
Tile connections as noted on plan	\$ 300.00
Contingency allowance for two additional equipment float moves (out and back in twice) to allow time for wet areas to drain	\$ 1,200.00
Tile connections and contingencies	\$ 4,300.00
Allowances under Sections 29 & 30 of the Drainage Act	\$ 11,230.00

BRANCH 3

Installation of the following concrete field tile by wheel machine including supply & installation of geotextile around tile joints (approx. 300m req'd)	
115 meters of 350mm dia. 2000D concrete tile	\$ 2,440.00
120 meters of 350mm dia. 2400D concrete tile	\$ 3,130.00
Supply of the above listed tile	\$ 5,060.00
Installation of the following concrete field tile and sewer pipe by excavator including supply & installation of geotextile around conc. tile joints (approx. 80m req'd) and supply and compaction of bedding material	
63 meters of 350mm dia. 2400D concrete tile	\$ 4,410.00
52 meters of 375mm dia. sewer pipe	\$ 4,160.00
Supply of the above listed tile and pipe	\$ 3,610.00
Contingency amount for increased cost due to poor soil conditions:	
Installation of tile on crushed stone bedding with excavator (100 meters)	\$ 2,500.00
Supply & delivery of 19mm crushed stone (Approx. 40 tonnes req'd)	\$ 870.00
Stripping, stockpiling topsoil and releveling upon completion (4m width)	\$ 2,600.00
Supply and install one 600mm x 600mm ditch inlet catchbasin including grates, berms, ditching	\$ 1,800.00
Construct swale to north and south of new catchbasin (90m total) including leveling excavated material	\$ 1,080.00
Contingency allowance for one additional equipment float move (out and back in) to allow time for wet area to drain	\$ 600.00
Tile connections and contingencies	\$ 3,300.00
Allowances under Sections 29 & 30 of the Drainage Act	\$ 5,310.00

SCHEDULE 'B' - COST ESTIMATE (cont'd)

BANNISTER DRAIN 2016
City of London**ADMINISTRATION**

Net Harmonized Sales Tax	\$	2,610.00
Permit To Take Water and supporting documentation	\$	5,000.00
Conservation Authority Review Fee	\$	300.00
Survey, Plan and Final Report	\$	30,730.00
Expenses	\$	320.00
Supervision and Final Inspection	\$	<u>8,000.00</u>
TOTAL ESTIMATED COST	\$	<u>179,800.00</u>

SCHEDULE 'C' - ASSESSMENT FOR CONSTRUCTION

BANNISTER DRAIN 2016

City of London

Job No. 211205

May 30, 2016

* = Non-agricultural

COM	LOT	HECTARES AFFECTED	ROLL No. (OWNER)	SPECIAL BENEFIT	BENEFIT	OUTLET	TOTAL	
BRANCH 1 (and Main Drain Deepening)								
<i>Geographic Westminster</i>								
	6	Pt.N½ 19	2.1	080-020-166(A. Hennessy)	\$	\$ 42.00	\$ 42.00	
*	6	Pt.N½ 20	2.2	080-020-167(London City)		42.00	42.00	
*	6	Pt.N½ 20	2.4	080-020-167-01(London City)		42.00	42.00	
*	6	Pt.N½ 20	0.80	080-020-168(London City)		14.00	14.00	
*	6	Pt.N½ 20	0.11	080-020-169(London City)		1.00	1.00	
*	6	Pt.N½ 20	1.7	080-020-170(London City)		28.00	28.00	
*	5	Pt.S½ 19	24.2	080-020-193(Brekelmans Holdings Limited)		401.00	401.00	
*	5	Pt.S½ 19	0.10	080-020-194(London City)		1.00	1.00	
	5	Pt.N½ 19	1.7	080-040-080(M. McDougall & J. Brochu)		28.00	28.00	
*	5	Pt.N½19& 20	10.1	080-040-081(1028026 Ontario Ltd.)		167.00	167.00	
*	5	Pt.S½ 20	20.2	080-020-191(Brekelmans Holdings Limited)		333.00	333.00	
*	5	Pt.S½ 20	18.9	080-020-190-10(1028026 Ontario Ltd)		319.00	319.00	
*	5	Pt. N½ 20	15.0	080-040-081-20(1028026 Ontario Ltd.)		250.00	250.00	
*	5	Pt. N½ 20	0.40	080-040-082(United Church of Canada)				
*	5	Pt. N½ 20	0.61	080-040-083(White Oaks Cemetery Trustees)		14.00	14.00	
*	5	Pt.N½20& 21	6.2	080-040-084-05(969726 Ontario Ltd.)		97.00	97.00	
*	5	Pt.S½ 21	2.5	080-020-189(S. Shirley)		42.00	42.00	
*	5	Pt.S½ 21	23.0	080-020-190(M. & A. & W. & C. Brown)		389.00	389.00	
	5	Pt. N½ 21	28.6	080-040-084 (969726 Ontario Ltd.)	13,310.00	15,271.00	28,581.00	
	5	Pt.S½21& 22	3.3	080-020-187(R. & D. McDougall)		139.00	139.00	
	5	N½ 22	14.8	080-040-085 (Lobban Farms Ltd.)	4,050.00	5,373.00	9,423.00	
	4	Pt. S½ 21	1.5	080-040-101 (W B C Holdings Ltd)		1,208.00	1,208.00	
*	4	Pt.E½S½ 22	2.0	080-040-097 (Cobrell Holdings Inc.)	10,210.00	444.00	10,654.00	
*		Right-of-Way		030-280-154(Hydro One Networks Inc)	5,570.00	670.00	6,240.00	
TOTAL ASSESSMENT ON LANDS					5,570.00	\$ 28,240.00	\$ 24,645.00	\$ 58,455.00
Westminster Dr.						\$ 40,520.00	\$ 5,412.00	\$ 45,932.00
White Oak Road							222.00	222.00
Scotland Dr.							278.00	278.00
Highway 401							943.00	943.00
TOTAL ASSESSMENT ON ROADS						\$ 40,520.00	\$ 6,855.00	\$ 47,375.00

SCHEDULE 'C' - ASSESSMENT FOR CONSTRUCTION (Cont'd)

BANNISTER DRAIN 2016
City of London

* = Non-agricultural

CON	LOT	HECTARES AFFECTED	ROLL No. (OWNER)	BENEFIT	OUTLET	TOTAL
BRANCH 1 (CON'T)						
SPECIAL ASSESSMENT against the City of London for the increased cost of boring a 458mm (18") dia. smooth wall pipe under Westminster Drive						\$ 12,080.00
SPECIAL ASSESSMENT to be charged out under maintenance to the Main Drain - Open Portion of the Bannister Drain 1984						\$ 5,980.00
TOTAL ASSESSMENT ON BRANCH 1						\$ 123,890.00
BRANCH 3						
<i>Geographic Westminster</i>						
6	Pt.N½ 19	2.1	080-020-166(A. Hennessy)	\$	\$ 76.00	\$ 76.00
* 6	Pt.N½ 20	2.2	080-020-167(London City)		85.00	85.00
* 6	Pt.N½ 20	2.4	080-020-167-01(London City)		95.00	95.00
* 6	Pt.N½ 20	0.8	080-020-168(London City)		28.00	28.00
* 6	Pt.N½ 20	0.1	080-020-169(London City)		0.00	0.00
* 6	Pt.N½ 20	1.7	080-020-170(London City)		66.00	66.00
* 5	Pt.S½ 19	24.2	080-020-193(Brekelmans Holdings Limited)		918.00	918.00
* 5	Pt.S½ 19	0.1	080-020-194(London City)		0.00	0.00
5	Pt.N½ 19	1.7	080-040-080(M. McDougall & J. Brochu)		66.00	66.00
* 5	Pt.N½19& 20	10.1	080-040-081(1028026 Ontario Ltd.)		379.00	379.00
* 5	Pt.S½ 20	20.2	080-020-191(Brekelmans Holdings Limited)		768.00	768.00
* 5	Pt.S½ 20	18.9	080-020-190-10(1028026 Ontario Ltd)		720.00	720.00
* 5	Pt. N½ 20	15.0	080-040-081-20(1028026 Ontario Ltd.)		569.00	569.00
* 5	Pt. N½ 20	0.4	080-040-082(United Church of Canada)		19.00	19.00
* 5	Pt. N½ 20	0.6	080-040-083(White Oaks Cemetery Trustees)		19.00	19.00
* 5	Pt.N½20& 21	6.2	080-040-084-05(969726 Ontario Ltd.)		237.00	237.00
* 5	Pt.S½ 21	2.5	080-020-189(S. Shirley)		95.00	95.00
* 5	Pt.S½ 21	23.0	080-020-190(M. & A. & W. & C. Brown)		872.00	872.00
5	Pt. N½ 21	17.1	080-040-084 (969726 Ontario Ltd.)	15,880.00	5,091.00	20,971.00
5	Pt.S½21& 22	3.3	080-020-187(R. & D. McDougall)		313.00	313.00
5	N½ 22	11.8	080-040-085 (Lobban Farms Ltd.)	16,880.00	7,811.00	24,691.00
TOTAL ASSESSMENT ON LANDS				\$ 32,760.00	\$ 18,227.00	\$ 50,987.00
* White Oak Road 3.5 City of London				\$	\$ 502.00	\$ 502.00
* Scotland Dr. 2.3 City of London					408.00	408.00
* Highway 401 9.4 Ministry of Transportation					4,013.00	4,013.00
TOTAL ASSESSMENT ON ROADS				\$	\$ 4,923.00	\$ 4,923.00
TOTAL ASSESSMENT ON THE BRANCH 3						\$ 55,910.00
TOTAL ASSESSMENT ON THE BANNISTER DRAIN 2016						\$ 179,800.00

SCHEDULE OF NET ASSESSMENT

BANNISTER DRAIN 2016

City of London

(FOR INFORMATION PURPOSES ONLY)

Job No. 211205

May 30, 2016

* = Non-agricultural

ROLL NUMBER (OWNER)	TOTAL ASSESSMENT	GRANT	ALLOWANCES	APPROX. NET
<i>Geographic Westminster</i>				
080-020-166(A. Hennessy)	\$ 118.00	\$ 39.00	\$	\$ 79.00
* 080-020-167(London City)	127.00			127.00
* 080-020-167-01(London City)	137.00			137.00
* 080-020-168(London City)	42.00			42.00
* 080-020-169(London City)	1.00			1.00
* 080-020-170(London City)	94.00			94.00
* 080-020-193(Brekelmans Holdings Limited)	1,319.00			1,319.00
* 080-020-194(London City)	1.00			1.00
080-040-080(M. McDougall & J. Brochu)	94.00	31.00		63.00
* 080-040-081(1028026 Ontario Ltd.)	546.00			546.00
* 080-020-191(Brekelmans Holdings Limited)	1,101.00			1,101.00
* 080-020-190-10(1028026 Ontario Ltd)	1,039.00			1,039.00
* 080-040-081-20(1028026 Ontario Ltd.)	819.00			819.00
* 080-040-082(United Church of Canada)	19.00			19.00
* 080-040-083(White Oaks Cemetery Trustees)	33.00			33.00
* 080-040-084-05(969726 Ontario Ltd.)	334.00			334.00
* 080-020-189(S. Shirley)	137.00			137.00
* 080-020-190(M. & A. & W. & C. Brown)	1,261.00			1,261.00
080-040-084 (969726 Ontario Ltd.)	49,552.00	16,517.00	3,140.00	29,895.00
080-020-187(R. & D. McDougall)	452.00	151.00		301.00
080-040-085 (Lobban Farms Ltd.)	34,114.00	11,371.00	7,420.00	15,323.00
080-040-101 (W B C Holdings Ltd)	1,208.00	403.00		805.00
* 080-040-097 (Cobrell Holdings Inc.)	10,654.00		5,240.00	5,414.00
* 030-280-154(Hydro One Networks Inc.)	6,240.00		740.00	5,500.00
Special Assessment to Bannister Drain 1984 - Main Drain - Open Portion	5,980.00	1,993.00		3,987.00
* Westminster Dr.	\$ 45,932.00	\$	\$	\$ 45,932.00
* Non-prorated Special Assessment	12,080.00			12,080.00
* White Oak Road	724.00			724.00
* Scotland Dr.	686.00			686.00
* Highway 401	4,956.00			4,956.00
TOTALS	\$ 179,800.00	\$ 30,505.00	\$ 16,540.00	\$ 132,755.00

**SPECIFICATIONS FOR CONSTRUCTION
OF
MUNICIPAL DRAINAGE WORKS**

GENERAL INDEX

SECTION A	General Conditions	Pages 1 to 9
SECTION B	Open Drain	Pages 10 to 12
SECTION C	Tile Drain	Pages 13 to 18
STANDARD DETAILED DRAWINGS		SDD-01 to SDD-05



SECTION A - GENERAL CONDITIONS

INDEX

<u>SECTION NUMBER</u>	<u>PAGE NO.</u>
A.1 SCOPE.....	1
A.2 TENDERS.....	1
A.3 DRAWINGS AND SPECIFICATIONS.....	1
A.4 PAYMENT.....	1
A.5 SUPERINTENDENT.....	1
A.6 COMMENCEMENT AND COMPLETION OF WORK.....	2
A.7 WORKING AREA AND ACCESS.....	2
A.8 SUPERVISION.....	2
A.9 INSPECTION.....	2
A.10 ALTERATIONS AND ADDITIONS.....	2
A.11 MAINTENANCE	3
A.12 INSURANCE.....	3
A.13 LIMITATIONS OF OPERATIONS.....	3
A.14 LOSSES.....	3
A.15 SUB-CONTRACTORS.....	3
A.16 PERMITS, NOTICES, LAWS AND RULES.....	3
A.17 ROAD CROSSINGS.....	4
A.18 FENCES.....	6
A.19 LIVESTOCK.....	6
A.20 STANDING CROPS	6
A.21 SURPLUS GRAVEL	6
A.22 RAILWAYS, HIGHWAYS, UTILITIES.....	6
A.23 LOCATION OF UTILITIES.....	7
A.24 TERMINATION OF CONTRACT BY THE MUNICIPALITY.....	7
A.25 ERRORS AND UNUSUAL CONDITIONS.....	7
A.26 IRON BARS	7
A.27 STAKES.....	7
A.28 RIP-RAP.....	8
A.29 GABION BASKETS.....	8
A.30 RESTORATION OF LAWNS.....	8
A.31 RESTORATION OF ROADS AND LANEWAYS.....	9

SECTION A

GENERAL CONDITIONS

A.1 SCOPE

The work to be done under this specification consists of supplying all labour, materials and equipment to construct the work as outlined on the drawing(s). In some Municipalities, the Contractor shall supply all materials while in other Municipalities, he shall supply only certain materials. The form of Tender and Agreement lists which materials are to be supplied by the Contractor.

A.2 TENDERS

Tenders are to be submitted on a lump sum basis for the complete works or a portion thereof, as set out in the Form of Tender and Agreement.

A.3 DRAWINGS AND SPECIFICATIONS

The tenderer must satisfy himself that he understands the meaning and intent of the drawings and specifications before submission of his tender. The standard specifications have been separated into sections for reference purpose only. They shall be considered complementary and, where a project is controlled under one of the sections, the remaining sections will still apply for miscellaneous works. In case of any inconsistency or conflict in the Tender Documents, the following order of precedence shall apply:

- Contract Drawings
- Form of Tender and Agreement
- General Conditions
- Standard Specifications (Open Drain, Tile Drain, Specifications for Municipal Drain Crossing County Roads)
- Standard Drawings

A.4 PAYMENT

Progress payments equal to 87±% of the value of the work done and materials incorporated in the work will be made to the Contractor on the written request of the Contractor to the Engineer. An additional 10±% will be paid 45 days after the final acceptance by the Engineer. Before this payment is released, the Contractor shall provide the Municipality with a Statutory Declaration that all material and/or labour incorporated in the work has been fully paid for, along with a Certificate of Clearance from the Workplace Safety and Insurance Board stating that all compensation has been paid. The Municipality will reserve 3%± of the Contract Price for one year as warranty. After the completion of the work, any part of this reserve may be used to correct defects which may develop within that time from faulty workmanship or material or loose backfill, provided that notice shall first be given to the Contractor and that he may promptly make good such defects, if he desires.

A.5 SUPERINTENDENT

The word "Superintendent", as used hereinafter in these specifications, shall refer to a Drainage Superintendent, appointed by the Municipality. The Superintendent will act as the Engineer's representative. The Superintendent shall have the power to direct the execution of the work and to make any necessary minor adjustments. Adjustments in tile sizes or gradients shall not be made without the approval of the Engineer. Any instructions given by the Superintendent, which changes considerably the proposed work or with which the Contractor does not agree, shall be referred to the Engineer for his decision.

A.6 COMMENCEMENT AND COMPLETION OF WORK

The work must commence immediately after the Contractor is notified of the acceptance of his tender or at a later date, if set out as a condition of the tender. If weather creates poor ground or working conditions, the Contractor may be required, at the discretion of the Engineer, to postpone or halt work until conditions become acceptable.

The Contractor shall give the Engineer and Superintendent a minimum of forty-eight (48) hours notice before commencement of work on any municipal drain. As noted on the plan, he can then arrange for a meeting to be held on the site with the Contractor and affected owners attending to review in detail the construction scheduling and other details. The Contractor's costs for attending this meeting shall be included in his lump sum tender price. If the Contractor leaves the job site for a period of time after initiation of work, he shall give the Engineer and the Superintendent a minimum of twenty-four (24) hours notice prior to returning to the project.

The work must be proceeded with in such a manner as to ensure its completion at the earliest possible date and within the time limit set out in the tender or in the contract documents.

A.7 WORKING AREA AND ACCESS

The working area available to the Contractor to construct the drain and related works including an access route to the drain shall be as specified on the drawings.

Should the specified widths become inadequate due to unusual conditions, the Contractor shall notify the Engineer immediately in order that negotiations with the affected owners can take place.

Where a Contractor exceeds the specified widths due to the nature of his operations and without authorization he shall be held responsible for the costs of all additional damages and the amount shall be deducted from his contract price and paid to the affected owners by the Municipality.

A.8 SUPERVISION

The Contractor shall give the work his constant supervision and shall keep a competent foreman in charge at the site.

A.9 INSPECTION

Final inspection by the Engineer will be made within twenty days after he has received notice in writing from the Contractor that the work is complete.

Periodic inspections by the Engineer or Superintendent will be made during the performance of the work. These interim inspections are required to check such items as location of drainage course and structures, tile grades prior to backfilling, backfilling and miscellaneous work items.

A.10 ALTERATIONS AND ADDITIONS

The Engineer shall have the power to make alterations in the work shown or described in the drawings or specifications and the Contractor shall proceed to make such changes without causing delay. In every such case, the price agreed to be paid for the work under the contract shall be increased or decreased as the case may require according to a fair and reasonable valuation of the work added or deleted. The valuation shall be determined as a result of negotiations between the Superintendent, the Contractor, and the Engineer, but in all cases, the Engineer shall maintain the final responsibility for the decision. Such alterations and variations shall in no way render void the contract. No claim for variations or alterations in the increased or decreased price shall be valid unless done in pursuance of an order from the Engineer and/or Superintendent and notice of such claims made in writing before commencement of such work. In no case shall the Contractor commence work which he considers to be extra work before receiving the Engineer's and/or Superintendent's approval in writing.

A.11 **MAINTENANCE**

The Contractor shall repair and make good any damages or faults in the drain that may appear within one year after its completion (as dated on the final completion certificate) as the result of imperfect or defective work done or materials furnished by the Contractor. Nothing herein contained shall be construed as in any way restricting or limiting the liability of the Contractor under the laws of the Country, Province or Locality in which the work is being done.

A.12 **INSURANCE**

- 1) Bodily Injury Liability: The Contractor shall effect and maintain, a Comprehensive General Liability Policy or its equivalent, covering claims for bodily injury, including death arising from and during operations under his Contract whether performed by himself, by a sub-contractor or by anyone directly or indirectly employed by either of them in the sum of \$ 2,000,000.00.
- 2) Property Damage: The Contractor shall effect and maintain Property Damage Liability Insurance to cover his and the sub-contractor's operations in the sum of \$ 1,000,000.00.
- 3) Fire Insurance: The Contractor shall procure fire and extended coverage insurance on the work to 100% of the Contract Amount.
- 4) The following are to be named as co-insured:
 - Successful Contractor
 - Sub-Contractor
 - Municipality
 - Spriet Associates London Limited
- 5) Within 7 days of award of Contract and prior to commencing work, the successful Contractor shall file with the Municipality, a copy of each insurance policy and certificate required. All such insurance shall be maintained until final completion of the work including the making good of faulty work or materials; except that coverage of completed operations liability shall in any event be maintained for twelve (12) months from the date of final completion as certified by the Engineer.

A.13 **LIMITATIONS OF OPERATIONS**

Except for such work as may be required by the Engineer to maintain the works in a safe and satisfactory condition, the Contractor shall not carry on his operations under the contract on Sundays without permission in writing of the Municipality.

A.14 **LOSSES**

The Contractor shall take all risks from floods or casualties of any kind.

A.15 **SUB-CONTRACTORS**

The Contractor shall not sublet the whole or any part of the contract without the approval of the Engineer or Superintendent.

A.16 **PERMITS, NOTICES, LAWS AND RULES**

The Contractor shall ensure that all necessary permits or licences required for the execution of the work have been obtained (but this shall not include M.T.O. encroachment permits, County Road Permit, permanent easements or rights of servitude). The Contractor shall give all necessary notices and pay all fees required by law and comply with all laws, ordinances, rules and regulations (including the Occupational Health and Safety Act) relating to the work and to the preservation of the public's health and safety and if the specifications and drawings are at variance therewith, any resulting additional expenses incurred by the Contractor shall constitute an addition to the contract price.

A.17 **ROAD CROSSINGS**

.1 **General**

- .1 **Scope**: These specifications apply to all road crossings - Municipal, County, Regional, or Highway Roads. Where the word "Authority" is used, it shall be deemed to apply to the appropriate owning authority. These specifications in no way limit the Authority's Specifications and Regulations governing the construction of drains on their Road Allowance. The Authority will supply no labour, equipment or materials for the construction of the road crossing unless otherwise noted on the drawings.
- .2 **Road Occupancy Permit**: Where applicable the Contractor must submit an Application for a Road Occupancy Permit to the Authority and allow a minimum of 5 working days (exclusive of holidays) for its review and issuance.
- .3 **Road Closure Request and Construction Notification**: The Contractor shall submit written notification of construction and request for road closure (if applicable) to the Road Authority/Public Works Manager and the Drainage Engineer or Superintendent for review and approval a minimum of five (5) working days (exclusive of holidays) prior to proceeding with any work on road allowance. It shall be the Road Authority's responsibility to notify all the applicable emergency services, schools, etc. of the road closure or construction taking place.
- .4 **Traffic Control**: Where the Contractor is permitted to close the road to through traffic, the Contractor shall provide for and adequately sign the detour route to the satisfaction of the Road Authority. Otherwise, the Contractor shall keep the road open to traffic at all times. The Contractor shall provide, for the supply, erection and maintenance, suitable warning signs and/or flagmen in accordance with the Manual of Uniform Traffic Control Devices and to the satisfaction of the Road Authority to notify the motorists of work on the road ahead.
- .5 **Site Meeting/Inspection**: A site meeting shall be held with the affected parties to review in detail the crossing and/or its related works. The Authority's Inspector and/or the Drainage Engineer will inspect the work while in progress to ensure that the work is done in strict accordance with the specifications.
- .6 **Weather**: No construction shall take place during inclement weather or periods of poor visibility.
- .7 **Equipment**: No construction material and/or equipment is to be left within 3 meters of the edge of pavement overnight or during periods of inclement weather.

.2 **Jacking and Boring**

- .1 **Material**: The bore pipe shall consist of new, smooth wall steel pipe, meeting the requirements of H20 loading for road crossings and E80 loading for railway crossings. The minimum size, wall thickness and length shall be as shown on the drawings. Where welding is required, the entire circumference of any joint shall be welded using currently accepted welding practices.
- .2 **Site Preparation and Excavation**: Where necessary, fences shall be carefully taken down as specified in the General Conditions. Prior to any excavation taking place, all areas which will be disturbed shall be stripped of topsoil. The topsoil is to be stockpiled in locations away from the bore operation, off the line of future tile placement and out of existing water runs or ditches. The bore pit shall be located at the upstream end of the bore unless otherwise specified or approved. Bore pits shall be kept back at least 1 meter from the edge of pavement and where bore pits are made in any portion of the shoulder, the excavated material shall be disposed of off the road allowance and the pit backfilled with thoroughly compacted Granular "A" for its entire depth.
- .3 **Installation**: The pipe shall be installed in specified line and grade by a combination of jacking and boring. Upon completion of the operations, both ends of the bore pipe shall be left uncovered until the elevation has been confirmed by the Engineer or Superintendent. The ends of the bore pipe shall be securely blocked off and the location marked by means of a stake extending from the pipe invert to 300mm above the surrounding ground surface.

.2 Jacking and Boring (cont'd)

- .4 Unstable Soil or Rock: The Contractor shall contact the Engineer immediately should unstable soil be encountered or if boulders of sufficient size and number to warrant concern are encountered. Any bore pipe partially installed shall be left in place until alternative methods or techniques are determined by the Engineer after consultation with the Contractor, the Superintendent and the owning authority.
- .5 Tile Connections: Prior to commencement of backfilling, all tile encountered in excavations shall be reconnected using material of a size comparable to the existing material. Where the excavation is below the tile grade, a compacted granular base is to be placed prior to laying the tile. Payment for each connection will be made at the rate outlined in the Form of Tender and Agreement.
- .6 Backfill: Unless otherwise specified, the area below the proposed grade shall be backfilled with a crushed stone bedding. Bore pits and excavations outside of the shoulder area may be backfilled with native material compacted to a density of 95% Standard Proctor. All disturbed areas shall be neatly shaped, have the topsoil replaced and hand seeded. Surplus material from the boring operation shall be removed from the site at the Contractor's expense.
- .7 Restoration: The entire affected area shall be shaped and graded to original lines and grades, the topsoil replaced, and the area seeded down at the rate of 85 kg/per ha. unless otherwise specified or in accordance with the M.T.O. Encroachment Permit. Fences shall be restored to their original condition in accordance with the General Conditions.
- .8 Acceptance: All work undertaken by the Contractor shall be to the satisfaction of the Engineer.

.3 Open Cut

- .1 Material: The culvert or sub-drain crossing pipe material shall be specified on the drawings.
- .2 Site Preparation and Excavation: Where necessary, fences shall be carefully taken down as specified in the general conditions. Prior to any excavation taking place, the areas which will be disturbed shall be stripped of topsoil. The topsoil is to be stockpiled in locations away from the construction area.
- .3 Installation: The pipe shall be installed using bedding and cover material in accordance with Standard Detailed Drawing No. 2 or detail provided on drawings.
- .4 Unstable Soil or Rock: The Contractor shall contact the Engineer immediately should unstable soil be encountered or if boulders of sufficient size and number to warrant concern are encountered.
- .5 Tile Connections: Prior to commencement of backfilling, all tiles encountered in excavations shall be reconnected using material of a size comparable to the existing material. Where the excavation is below the tile grade, a compacted granular base is to be placed prior to laying the tile. Payment for connections not shown on the drawings shall be an extra to the contract.
- .6 Backfill: Backfill from the top of the cover material up to the under side of road base shall meet the requirements for M.T.O. Granular "B". The backfill shall be placed in lifts not exceeding 300mm in thickness and each lift shall be thoroughly compacted to produce a density of 98% Standard Proctor. Granular "B" road base for County Roads and Highways shall be placed to a 450mm thickness and Granular "A" shall be placed to a thickness of 200mm, both meeting M.T.O. requirements. Granular road base materials shall be thoroughly compacted to produce a density of 100% Standard Proctor.

Where the road surface is paved, the Contractor shall be responsible for placing an HL-4 Hot Mix Asphalt patch of the same thickness as the existing pavement. The asphalt patch shall be flush with the existing roadway on each side and not overlap. If specified, the asphalt patch shall not be placed immediately over the road base and the Granular "A" shall be brought up flush with the existing asphalt and a liberal amount of calcium chloride shall be spread on the gravel surface. The asphalt patch must be completed within the time period set out on the drawing.

.3 **Open Cut** (cont'd)

The excavated material from the trench beyond a point 1.25 meters from the travelled portion or beyond the outside edge of the gravel shoulder, may be used as backfill in the trench in the case of covered drains. This material should be compacted in layers not exceeding 600mm.

A.18 **FENCES**

No earth shall be placed against fences and all fences removed by the Contractor are to be replaced by him in as good condition as found. In general, the Contractor will not be allowed to cut existing fences but shall disconnect existing fences at the nearest anchor post or other such fixed joint and shall carefully roll it back out of the way. Where the distance to the closest anchor post or fixed joint exceeds 50 meters, the Contractor will be allowed to cut and splice in accordance with accepted methods and to the satisfaction of the owner and the Engineer or Superintendent. Where existing fences are deteriorated to the extent that existing materials are not salvageable for replacement, the Contractor shall notify the Engineer or the Superintendent prior to dismantling. Fences damaged beyond salvaging by the Contractor's negligence shall be replaced with new materials, similar to those existing, at the Contractor's expense. The replacement of the fences shall be done to the satisfaction of the owner and the Engineer or Superintendent. The site examination should indicate to the Contractor such work, if any, and an allowance should be made in the tendered price.

The Contractor shall not leave any fence open when he is not at work in the immediate vicinity.

A.19 **LIVESTOCK**

The Contractor shall provide each property owner with 48 hours notice prior to removing any fences along fields which could possibly contain livestock. Thereafter, the property owner shall be responsible to keep all livestock clear of the construction areas until further notified. Where necessary, the Contractor will be directed to erect temporary fences. The Contractor shall be held responsible for loss or injury to livestock or damage caused by livestock, where the injury or damage is caused by his failure to notify the property owner or through negligence or carelessness on the part of the Contractor.

The Contractor constructing a tile drain shall not be held responsible for damages or injury to livestock occasioned by leaving trenches open for inspection by the Engineer if he notifies the owner at least 48 hours prior to commencement of the work on that portion. The Contractor will be held liable for such damages or injury if the backfilling of such trenches is delayed more than 1 day after acceptance by the Engineer.

A.20 **STANDING CROPS**

The Contractor shall not be held responsible for damages to standing crops within the working area available and the access route provided if he notifies the owner thereof at least 48 hours prior to commencement of the work on that portion.

A.21 **SURPLUS GRAVEL**

If as a result of any work, gravel or crushed stone is required and not all the gravel or crushed stone is used in the construction of the works, the Contractor shall haul away such surplus gravel or stone unless otherwise approved.

A.22 **RAILWAYS, HIGHWAYS, UTILITIES**

A minimum of forty-eight (48) hours notice to Railways, Highways and Utilities, exclusive of Saturdays, Sundays and Holidays, shall be required by the Contractor prior to any work being performed and in the case of a pipe being installed by open cutting or boring under a Highway or Railway, a minimum of 72 hours notice is required.

A.23 UTILITIES

The attention of the Contractor is drawn to the presence of utilities along the course of the drain. The contractor will be responsible for determining the location of all utilities and will be held liable for any damage to all utilities caused by his operations. The Contractor shall co-operate with all authorities to ensure that all utilities are protected from damage during the performance of the work. The cost of any necessary relocation work shall be borne by the utility. No allowance or claims of any nature will be allowed on account for delays or inconveniences due to utilities relocation, or for inconveniences and delays caused by working around or with existing utilities not relocated.

A.24 TERMINATION OF CONTRACT BY THE MUNICIPALITY

If the Contractor should be adjudged bankrupt, or if he should make a general assignment for the benefit of his creditors, or if a receiver should be appointed on account of his insolvency, or if he should refuse or fail to supply enough properly skilled workmen or proper materials after having received seven (7) days notice in writing from the Engineer to supply additional workmen or materials, or if he should fail to make prompt payment to sub-contractors or for material or labour or persistently disregarding laws, ordinances, or the instruction of the Engineer, or otherwise being guilty of a substantial violation of the provisions of the contract, then the Municipality, upon the certification of the Engineer that sufficient cause exists to justify such action, may without prejudice to any other right or remedy, by giving the contractor written notice, terminate the employment of the contractor and take possession of the premises and of all materials, tools and appliances, thereon, and complete the work by whatever method the Engineer may deem expedient, but without undue delay or expense. In such case, the Contractor shall not be entitled to receive any further payment until the work is completed. If the unpaid balance of the contract price exceeds the expense of completing the work, including compensation to the Engineer for his additional services, such excess shall be paid to the Contractor. If such expense does not exceed such unpaid balance, the Contractor shall pay the difference to the Municipality. The expense incurred by the Municipality, as herein provided, shall be certified by the Engineer. Where a Contractor fails to commence work within seven (7) days of his commencement date as indicated by him on his Tender Form, and such extension of time as allowed due to poor weather or ground conditions, then the Municipality shall have the option, after providing the Contractor with seven (7) days notice of their intention to terminate the contract, award the contract to another Contractor at their discretion by retendering the project, inviting bids or by appointment. The additional costs of the above or retendering, and all other administration costs shall be deducted from the Contractor's bid deposit and the balance, if any, returned to him.

A.25 ERRORS AND UNUSUAL CONDITIONS

The Contractor shall notify the Engineer immediately of any error or unusual condition which may be found. Any attempt by the Contractor to make changes because of the error or unusual condition on his own shall be done at his own risk. Any additional cost incurred by the Contractor to remedy a wrong decision on his part shall be borne by the Contractor.

The Engineer shall make the alteration necessary to correct errors or to adjust for unusual conditions during which time it will be the Contractor's responsibility to keep his men and equipment gainfully employed elsewhere on the project. The contract amount shall be adjusted in accordance with a fair evaluation of the work added or deleted.

A.26 IRON BARS

The Contractor shall be held liable for the cost of an Ontario Land Surveyor to replace any iron bars destroyed during the course of construction.

A.27 STAKES

At the time of the survey, stakes are set along the course of the drain at intervals of 50 meters. The Contractor shall ensure that the stakes are not disturbed unless approval is obtained from the Engineer. Any stakes removed by the Contractor without the authority of the Engineer, shall be replaced at the expense of the Contractor. At the request of the Contractor, any stakes which are removed or disturbed by others or by livestock, shall be replaced at the expense of the drain.

A.28 **RIP-RAP**

Rip-rap shall be specified on the drawings and shall conform to the following:

- .1 **Quarry Stone**: shall range in size from 150mm to 300mm evenly distributed and shall be placed to a 300mm thickness on a filter blanket at a 1.5 : 1 slope unless otherwise noted. Filter blanket to be Mirafi 160N or approved equal.
- .2 **Broken Concrete**: may be used in areas outside of regular flows if first broken in maximum 450mm sized pieces and mixed to blend with quarry stone as above. No exposed reinforcing steel shall be permitted.
- .3 **Shot Rock**: shall range in size from 150mm to 600mm placed to a depth of 450mm thickness on a filter blanket at a 1.5:1 slope unless otherwise noted. Filter blanket to be Mirafi 160N or approved equal.

A.29 **GABION BASKETS**

Supply and install gabion basket rip-rap protection as shown on the drawings.

Gabion baskets shall be as manufactured by Maccaferri Gabions of Canada Ltd. or approved equal and shall be assembled and installed in strict accordance with the manufacturer's recommendations.

The gabion fill material shall consist solely of fractured field stone or gabion stone graded in size from 100mm to 200mm (4" to 8") and shall be free of undersized fragments and unsuitable material.

A.30 **RESTORATION OF LAWNS**

- .1 **General**: Areas noted on the drawings to be restored with seeding or sodding shall conform to this specification, and the contractor shall allow for all costs in his lump sum bid for the following works.
- .2 **Topsoil**: Prior to excavation, the working area shall be stripped of existing topsoil. The topsoil stockpile shall be located so as to prevent contamination with material excavated from the trench. Upon completion of backfilling operations, topsoil shall be spread over the working area to a depth equal to that which previously existed but not less than the following:

Seeding and sodding	-	minimum depth of 100mm
Gardens	-	minimum depth of 300mm

In all cases where a shortfall of topsoil occurs, whether due to lack of sufficient original depth or rejection of stockpiled material due to contractors operations, imported topsoil from acceptable sources shall be imported at the contractors expense to provide the specified depths. Topsoil shall be uniformly spread, graded and cultivated prior to seeding or sodding. All clods or lumps shall be pulverized and any roots or foreign matter shall be raked up and removed as directed.

.3 **Sodding**

- .1 **Materials**: Nursery sod to be supplied by the contractor shall meet the current requirements of the Ontario Sod Growers Association for No. 1 Bluegrass Fescue Sod.
- .2 **Fertilizer**: Prior to sod placement, approved fertilizer shall be spread at the rate of 5kg/100m² of surface area and shall be incorporated into such surfaces by raking, discing or harrowing. All surfaces on which sod is to be placed shall be loose at the time of placing sod to a depth of 25mm.
- .3 **Placing Sod**: Sod shall be laid lengthwise across the face of slopes with ends close together. Sod shall be counter sunk along the joints between the existing grade and the new sodding to allow for the free flow of water across the joint. Joints in adjacent rows shall be staggered and all joints shall be pounded and rolled to a uniform surface.

A.30 **RESTORATION OF LAWNS** (cont'd)

On slopes steeper than 3:1, and in unstable areas, the engineer may direct the contractor to stake sod and/or provide an approved mesh to prevent slippages. In all cases where such additional work is required, it will be deemed an extra to the contract and shall be paid for in accordance with the General Conditions.

No sod shall be laid when frozen nor upon frozen ground nor under any other condition not favourable to the growth of the sod. Upon completion of sod laying the contractor shall thoroughly soak the area with water to a depth of 50mm. Thereafter it will be the responsibility of the property owner to maintain the area in a manner so as to promote growth.

.4 **Seeding**: Seed to be supplied by the contractor shall be "high quality grass seed" harvested during the previous year, and shall be supplied to the project in the suppliers original bags on which a tag setting out the following information is affixed:

- Year or Harvest - recommended rate of application
- Type of Mixture - fertilizer requirements

Placement of seed shall be by means of an approved mechanical spreader. All areas on which seed is to be placed shall be loose at the time of placing seed, to a depth of 25mm. Seed and fertilizer shall be spread in accordance with the suppliers recommendations unless otherwise directed by the Engineer. Thereafter it will be the responsibility of the property owner to maintain the area in a manner so as to promote growth.

.5 **Settlement**: The contractor shall be responsible during the one year guarantee period for the necessary repair of restored areas due to trench settlement. Areas where settlement does not exceed 50mm may be repaired by top dressing with fine topsoil. In areas where settlement exceeds 50mm, the contractor will be required to backfill the area with topsoil and restore with seeding and/or sodding as originally specified.

A.31 **RESTORATION OF ROADS AND LANEWAYS**

.1 **Gravel**: Restoration shall be in accordance with the applicable standard detailed drawing or as shown on the drawings.

.2 **Asphalt and Tar and Chip**: Prior to restoration all joints shall be neatly sawcut. Restoration shall be as a in gravel above with the addition of the following:

- .1 Roads shall have the finished grade of Granular 'A', allow two courses of hot-mix asphalt (M.T.O. 310), 80mm HL6 and 40mm HL3 or to such greater thickness as may be required to match the existing.
- .2 Laneways shall have the finished grade of Granular 'A' allow one 50mm minimum course of hot-mix asphalt (HL3) or greater as may be required to match existing.

SECTION B - OPEN DRAIN

INDEX

<u>SECTION NUMBER</u>		<u>PAGE NUMBER</u>
B.1	PROFILE.....	10
B.2	ALIGNMENT.....	10
B.3	CLEARING AND GRUBBING.....	10
B.4	EXCAVATION.....	10
B.5	EXCAVATED MATERIAL.....	11
B.6	EXCAVATION THROUGH BRIDGES AND CULVERTS.....	11
B.7	PIPE CULVERT.....	11
B.8	MOVING DRAINS OFF ROADS.....	11
B.9	TRIBUTARY OUTLETS.....	12
B.10	SEDIMENT BASINS AND TRAPS.....	12
B.11	SEEDING.....	12

SECTION B**OPEN DRAIN****B.1 PROFILE**

The profile drawing shows the depth of cuts from the ground beside the stake to the final invert of the ditch in meters and decimals of a meter and also the approximate depth of cuts from the existing bottom of the ditch to the elevation of the ditch bottom. These cuts are established for the convenience of the Contractor; however, bench marks will govern the final elevation of the drain. Bench marks have been established along the course of the drain and their locations and elevations are noted on the profile drawing. A uniform grade shall be maintained between stakes in accordance with the profile drawing.

B.2 ALIGNMENT

The drain shall be constructed in a straight line and shall follow the course of the present drain or water run unless otherwise noted on the drawings. Where it is necessary to straighten any bends or irregularities in alignment not noted on the drawings, the Contractor shall contact the Engineer or Superintendent before commencing the work.

B.3 CLEARING AND GRUBBING

Prior to commencement of work, all trees, scrub, fallen timber and debris shall be removed from the side slopes of the ditch and for such a distance on the working side so as to eliminate any interference with the construction of the drain or the spreading of the spoil. The side slopes shall be neatly cut and cleared flush with slope whether or not they are affected directly by the excavation. With the exception of large stumps causing damage to the drain, the sideslope shall not be grubbed. All other cleared areas shall be grubbed and the stumps put into piles for disposal by the owner.

All trees or limbs 150mm (6") or larger, that it is necessary to remove, shall be considered as logs and shall be cut and trimmed, and left in the working width separate from the brush, for use or disposal by the owner. Trees or limbs less than 150mm in diameter shall be cut in lengths not greater than 5 meters and placed in separate piles with stumps spaced not less than 75 meters apart in the working width, for the use or disposal of the owner. In all cases, these piles shall be placed clear of excavated materials, and not be piled against standing trees. No windrowing will be permitted. The clearing and grubbing and construction of the drain are to be carried out in two separate operations and not simultaneously at the same location.

B.4 EXCAVATION

The bottom width and the side slopes of the ditch shall be those shown on the profile drawing.

Unless otherwise specified on the drawings, only the existing ditch bottom is to be cleaned out and the side slopes are not to be disturbed. Where existing side slopes become unstable because of construction, the Contractor shall immediately contact the Engineer or Superintendent. Alternative methods of construction and/or methods of protection will then be determined, prior to continuing the work.

Where an existing drain is being relocated or where a new drain is being constructed, the Contractor shall, unless otherwise specified, strip the topsoil for the full width of the drain, including the location of the spoil pile. Upon completion of levelling, the topsoil shall be spread to an even depth across the full width of the spoil.

B.5 EXCAVATED MATERIAL

Excavated material shall be deposited on either or both sides of the drain as indicated on the drawings or as directed by the Engineer or Superintendent. A buffer strip of not less than 3 meters in width through farmed lands and 2 meters in width through bush areas shall be left along the top edges of the drain. The buffer strip shall be seeded and/or incorporated as specified on the drawings. The material shall be deposited beyond the specified buffer strip.

No excavated material shall be placed in tributary drains, depressions, or low areas which direct water into the ditch so that water will be trapped behind the spoilbank. The excavated material shall be placed and levelled to a minimum width to depth ratio of 50:1 unless instructed otherwise. The edge of the spoilbank away from the ditch shall be feathered down to the existing ground; the edge of the spoilbank nearest the ditch shall have a maximum slope of 2 to 1. The material shall be levelled such that it may be cultivated with ordinary farm equipment without causing undue hardship on machinery and personnel. No excavated material shall cover any logs, scrub, debris, etc. of any kind.

Where it is necessary to straighten any unnecessary bends or irregularities in the alignment of the ditch, the excavated material from the new cut shall be used for backfilling the original ditch. Regardless of the distance between the new ditch and the old ditch no extra compensation will be allowed for this work and must be included in the Contractor's lump sum price for the open work.

Any stones 150mm or larger left exposed on top of the levelled excavated material shall be removed and disposed of as an extra to the contract unless otherwise noted on plans.

B.6 EXCAVATION THROUGH BRIDGES AND CULVERTS

The Contractor shall excavate the drain to the full specified depth and width under all bridges. Where the bridge or culvert pipe is located within a road allowance, the excavated material shall be levelled within the road allowance. Care shall be taken not to adversely affect existing drainage patterns. Temporary bridges may be carefully removed and left on the bank of the drain but shall be replaced by the Contractor when the excavation is completed unless otherwise specified. Permanent bridges must be left intact. All necessary care and precautions shall be taken to protect the structure. The Contractor shall notify the Engineer or Superintendent if excavation may cause the structure to undermine or collapse.

B.7 PIPE CULVERTS

Where specified on the drawings, the existing culvert shall be carefully removed, salvaged and either left at the site for the owner or reinstalled at a new grade or location. The value of any damage caused to the culvert due to the Contractor's negligence in salvage operation will be determined and deducted from the contract price.

All pipe culverts shall be installed in accordance with the standard detail drawings as noted on the drawings. If couplers are required, 5 corrugation couplers shall be used for up to and including 1200mm dia. pipe and 10 corrugation couplers for greater than 1200mm dia.

B.8 MOVING DRAINS OFF ROADS

Where an open drain is being removed from a road allowance, it must be reconstructed wholly on the adjacent lands with a minimum distance of 2.0 meters between the property line and the top of the bank, unless otherwise noted on the drawings. The excavated material shall be used to fill the existing open ditch and any excess excavated material shall be placed and levelled on the adjacent lands beyond the buffer strip, unless otherwise noted. Any work done on the road allowance, with respect to excavation, disposal of materials, installation of culverts, cleaning under bridges, etc., shall be to the satisfaction of the Road Authority and the Engineer.

B.9 TRIBUTARY OUTLETS

The Contractor shall guard against damaging the outlets of tributary drains. Prior to commencement of excavation on each property the Contractor shall contact the owner and request that all known outlet pipes be marked by the owner. All outlets so marked or visible or as noted on the profile, and subsequently damaged by the Contractor's operations will be repaired by the Contractor at his cost. All outlet pipes repaired by the Contractor under direction of the Drainage Superintendent or Engineer which were not part of the Contract shall be considered an extra to the contract price.

B.10 SEDIMENT BASINS AND TRAPS

The Contractor shall excavate sediment basins prior to commencement of upstream work as shown on the plan and profile. The dimension of the basin will be in a parabolic shape with a depth of 450mm below the proposed ditch bottom and the basin will extend along the drain for a minimum length of 15 meters.

A sediment trap 300mm deep and 5 meters long with silt fence placed across ditch bottom on the downstream end of the trap shall be constructed prior to and maintained during construction, to prevent silt from flushing downstream. The silt fence shall be removed and disposed of after construction.

B.11 SEEDING

- .1 **Delivery:** The materials shall be delivered to the site in the original unopened containers which shall bear the vendor's guarantee of analysis and seed will have a tag showing the year of harvest.
- .2 **Hydro Seeding:** Areas specified on drawings shall be hydro seeded and mulched upon completion of construction in accordance with O.P.S.S. 572 and with the following application rates:

Primary Seed (85 kg/ha.):	50% Creeping Red Fescue 40% Perennial Ryegrass 5% White Clover
Nurse Crop	Italian (Annual) Ryegrass at 25% of Total Weight
Fertilizer (300 kg/ha.)	8-32-16
Hydraulic Mulch (2000 kg/ha.)	Type "B"
Water (52,700 litres/ha.)	

Seeding shall not be completed after September 30.

- .3 **Hand Seeding:** Hand seeding shall be completed daily with the seed mixture and fertilizer and application rate shown under "Hydro Seeding" above. Placement of the seed shall be by means of an approved mechanical spreader. Seeding shall not be completed after September 30.

SECTION C - TILE DRAIN

I N D E X

<u>SECTION NUMBER</u>		<u>PAGE NUMBER</u>
C.1	PIPE MATERIALS.....	13
C.2	TESTING.....	13
C.3	LINE.....	13
C.4	CLEARING AND GRUBBING.....	14
C.5	PROFILE.....	14
C.6	GRADE.....	14
C.7	EXCAVATION.....	15
C.8	INSTALLATION.....	15
C.9	ROAD AND LANEWAY SUB-SURFACE CROSSINGS.....	16
C.10	BACKFILLING.....	16
C.11	UNSTABLE SOIL.....	16
C.12	ROCKS.....	16
C.13	BROKEN, DAMAGED OR EXCESS TILE.....	16
C.14	TRIBUTARY DRAINS.....	16
C.15	OUTLET PIPES.....	17
C.16	CATCHBASINS AND JUNCTION BOXES.....	17
C.17	BLIND INLETS.....	18
C.18	GRASSED WATERWAY.....	18
C.19	BACKFILLING EXISTING DITCHES.....	18
C.20	RECOMMENDED PRACTICE FOR CONSTRUCTION OF SUBSURFACE DRAINAGE SYSTEM.....	18

SECTION C

TILE DRAIN

C.1 PIPE MATERIALS

- .1 **Concrete Tile:** All tile installed under these specifications shall be sound and of first quality and shall meet all A.S.T.M. Specifications current at the time of tendering. Concrete tile shall conform to Designation C412 "Extra Quality" except that the minimum compression strengths shall be increased by 25%. Heavy Duty tile shall conform to Designation C412 "Heavy Duty Extra Quality".
- .2 **Corrugated Steel Pipe:** Unless otherwise specified all metal pipe shall be corrugated, rivetted steel pipe or helical corrugated steel pipe with a minimum wall thickness of 1.6mm (16 gauge) and shall be fully galvanized.
- .3 **Plastic Tubing:** The plans will specify the type of tubing or pipe, such as non-perforated or perforated (with or without filter material).
 - i) Corrugated Plastic Drainage Tubing shall conform to the current O.F.D.A. Standards
 - ii) Heavy Duty Corrugated Plastic Pipe shall be "Boss 1000" manufactured by the Big 'O' Drain Tile Co. Ltd. or approved equal
- .4 **Concrete Sewer Pipe:** The Designations for concrete sewer pipe shall be C14 for concrete sewer pipe 450mm (18") diameter or less; and C76 for concrete sewer pipe greater than 450mm (18") diameter. Where closed joints are specified, joints shall conform to the A.S.T.M. Specification C443.
Where concrete sewer pipe "seconds" are permitted the pipe should exhibit no damages or cracks on the barrel section and shall be capable of satisfying the crushing strength requirements for No. 1, Pipe Specifications (C14 or C76). The pipe may contain cracks or chips in the bell or spigot which could be serious enough to prevent the use of rubber gaskets but which are not so severe that the joint could not be mortared conventionally.
- .5 **Plastic Sewer Pipe:** The plans will specify the type of sewer pipe, such as non-perforated or perforated (with or without filter material). All plastic sewer pipe and fittings shall be "Boss Poly-Tite", ULTRA-RIB", "Challenger 3000" or approved equal with a minimum stiffness of 320 kpa at 5% deflection..
- .6 **Plastic Fittings:** All plastic fittings shall be "Boss 2000" or "Challenger 2000" with split coupler joints or approved equal.

C.2 TESTING

The manufacturer shall provide specimens for testing if required. The random selection and testing procedures would follow the appropriate A.S.T.M. requirements for the material being supplied. The only variation is the number of tile tested: 200mm to 525mm dia. - 5 tile tested, 600mm to 900mm dia. - 3 tile tested. The drain will be responsible for all testing costs for successful test results. Where specimens fail to meet the minimum test requirements, the manufacturer will be responsible for the costs of the unsuccessful tests. Alternately, the Engineer may accept materials on the basis of visual inspections and the receipt in writing from the Manufacturer of the results of daily production testing carried out by the Manufacturer for the types and sizes of the material being supplied.

C.3 LINE

Prior to stringing the tile, the Contractor shall contact the Superintendent or the Engineer in order to establish the course of the drain.

Where an existing drain is to be removed and replaced in the same trench by the new drain or where the new drain is to be installed parallel to an existing drain, the Contractor shall excavate test holes to locate the existing drain (including repairing drainage tile) at intervals along the course of the drain as directed by the Engineer and/or the Superintendent. The costs for this work shall be included in the tender price.

C.3 **LINE** (cont'd)

Where an existing drain is to be removed and replaced in the same trench by the new drain, all existing tiles shall be destroyed and all broken tile shall be disposed of off site.

The drain shall run in as straight a line as possible throughout its length, except that at intersections of other water courses or at sharp corners, it shall run on a curve of at least a 15 meter radius. The new tile drain shall be constructed at an offset from and generally parallel with any ditch or defined watercourse in order that fresh backfill in the trench will not be eroded by the flow of surface water. The Contractor shall exercise care not to disturb any existing tile drain or drains which parallel the course of the new drain, particularly where the new and the existing tile act together to provide the necessary capacity.

C.4 **CLEARING AND GRUBBING**

Prior to commencement of drain construction, all trees, scrub, fallen timber and debris shall be cleared and grubbed from the working area. Unless otherwise specified, the minimum width to be cleared and grubbed shall be 20 meters in all hardwood areas and 30 meters in all softwood areas (willow, poplar, etc.), the width being centred on the line of the drain.

All trees or limbs 150mm (6") or larger, that it is necessary to remove, shall be considered as logs and shall be cut and trimmed, and left in the working width separate from the brush, for use or disposal by the owner. Trees or limbs less than 150mm in diameter shall be cut in lengths not greater than 5 meters and placed in separate piles with stumps spaced not less than 75 meters apart in the working width, for the use or disposal of the owner. In all cases, these piles shall be placed clear of excavated materials, and not be piled against standing trees. No windrowing will be permitted. The clearing and grubbing and construction of the drain are to be carried out in two separate operations and not simultaneously at the same location.

C.5 **PROFILE**

The profile drawing shows the depth of cuts from the ground beside the stake to the final invert of the drain in meters and decimals of a meter. These cuts are established for the convenience of the Contractor; however, bench marks will govern the final elevation of the drain. Bench marks have been established along the course of the drain and their locations and elevations are noted on the profile drawing.

C.6 **GRADE**

The Contractor shall provide and maintain in good working condition, an approved system of establishing a grade sight line to ensure the completed works conform to the profile drawing. In order to confirm the condition of his system and to eliminate the possibility of minor errors on the drawings, he shall ensure his grade sight line has been confirmed to be correct between a minimum of two control points (bench marks) and shall spot check the actual cuts and compare with the plan cuts prior to commencement of tile installation. He shall continue this procedure from control point to control point as construction of the drain progresses. When installing a drain towards a fixed point such as a bore pipe, the Contractor shall uncover the pipe and confirm the elevation, using the sight line, a sufficient distance away from the pipe in order to allow for any necessary minor grade adjustments to be made in order to conform to the as built elevation of the bore pipe. All tile improperly installed due to the Contractor not following these procedures shall be removed and replaced entirely at the Contractor's cost.

When following the procedures and a significant variation is found, the Contractor shall immediately cease operations and advise the Engineer.

C.7 EXCAVATION

- .1 **Trench:** Unless otherwise specified, all trenching shall be done with a recognized farm tiling machine approved by the Engineer or Superintendent. The machine shall shape the bottom of the trench to conform to the outside diameter of the pipe for a minimum width of one-half of the outside diameter. The minimum trench width shall be equal to the outside diameter of the tile to be installed plus 100mm (4") on each side unless otherwise approved. The maximum trench width shall be equal to the outside diameter of the tile to be installed plus 250mm (10") on each side unless otherwise approved.
- .2 **Scalping:** Where the depths of cuts in isolated areas along the course of the drain as shown on the profile exceed the capacity of the Contractor's tiling machine, he shall lower the surface grade in order that the tiling machine may trench to the correct depth. Topsoil is to be stripped over a sufficient width that no subsoil will be deposited on top of topsoil. Subsoil will then be removed to the required depth and piled separately. Upon completion of backfilling, the topsoil will then be replaced to an even depth over the disturbed area. The cost for this work shall be included in his tender price.
- .3 **Excavator:** Where the Contractor's tiling machine consistently does not have the capacity to dig to the depths required or to excavate the minimum trench width required, he shall indicate in the appropriate place provided on the tender form his proposed methods of excavation.
Where the use of an excavator is either specified on the drawings or approved as evidenced by the acceptance of his tender on which he has indicated the proposed use of a backhoe he shall conform to the following requirements:
 - a) the topsoil shall be stripped and replaced in accordance with Section .2 "Scalping".
 - b) all tile shall be installed on a bed of 19mm crushed stone with a minimum depth of 150mm which has been shaped to conform to the lower segment of the tile.
 - c) the Contractor shall allow for the cost of the preceding requirements (including the supply of the crushed stone) in his lump sum tender price unless it is otherwise provided for in the contract documents.
- .4 **Backfilling Ditch:** Where the contract includes for a closed drain to replace an open drain and the ditch is to be backfilled, the Contractor shall install the tile and backfill the trench prior to backfilling the ditch unless otherwise noted. The distance the trench shall be located away from the ditch shall be as noted on the drawings, (beyond area required for stockpiling topsoil and backfilling). After tile installation is complete topsoil (if present) shall be stripped and stockpiled within the above limits prior to backfilling of ditch. Only tracked equipment shall be permitted to cross backfilled tile trench and must be at 90 degrees to line of tile.

C.8 INSTALLATION

The tile is to be laid with close fitting joints and in regular grade and alignment in accordance with the plan and profile drawings. The tiles are to be bevelled, if necessary, to ensure close joints (in particular around curves). Where, in heavy clay soils, the width of a joint exceeds 10mm the joint shall be wrapped with filter cloth as below. Where the width of a joint exceeds 12mm the tile shall first be removed and the joint bevelled to reduce the gap. The maximum deflection of one tile joint shall be 15 degrees. Where a drain connects to standard or ditch inlet catchbasins or junction box structures, the Contractor shall include in his tender price for the supply and installation of compacted Granular 'A' bedding under areas backfilled from the underside of the pipe to undisturbed soil. The connections will then be grouted.

Where a tile drain passes through a bore pit, the Tile Contractor shall include in his tender price for the supply and placement of compacted Granular "A" bedding from the underside of the pipe down to undisturbed soil within the limits of the bore pit.

As above and where soil conditions warrant, the Engineer may require (or as specified on the drawings) that each tile joint be wrapped with synthetic filter cloth. The width of the filter cloth shall be 300mm wide for tile sizes of 150mm to 300mm and 400mm wide for sizes of 350mm to 750mm. The filter cloth shall cover the full perimeter of the tile and overlap a minimum of 100mm or as specified on the drawings. The type of cloth shall be Mirafi 140NL for loam soils and 150N for sandy soil. Any such work not shown on the drawings shall be considered as an addition to the contract price unless specified on the drawings.

C.9 ROAD AND LANEWAY SUB-SURFACE CROSSINGS

All road and laneway crossings may be made with an open cut in accordance with standard detailed drawings in the specifications or on the drawings. The exact location of the crossing shall be verified and approved by the Road Authority and the Engineer and/or superintendent.

C.10 BACKFILLING

As the laying of the tile progresses, blinding up to the springline including compaction by tamping (by hand) is to be made on both sides of the tile. No tile shall be backfilled until inspected by the Engineer or Drainage Superintendent unless otherwise approved by the Engineer.

The remainder of the trench shall be backfilled with special care being taken in backfilling up to a height approximately 150mm above the top of the tile to ensure that no tile breakage occurs. During the backfilling operation no equipment shall be operated in a way that would transfer loads onto the tile trench. Surplus material is to be mounded over the tile trench so that when settlement takes place the natural surface of the ground will be restored. Upon completion, a minimum cover of 600mm is required over all tile. Where stones larger than 150mm are present in the backfill material, they shall be separated from the material and disposed of by the Contractor.

Where a drain crosses a lawn area, the backfilling shall be carried out as above except that, unless otherwise specified, the backfill material shall be mechanically compacted to eliminate settlement.

C.11 UNSTABLE SOIL

The Contractor shall immediately contact the Engineer or Superintendent if quicksand is encountered, such that installation with a tiling machine is not possible. The Engineer shall, after consultation with the Superintendent and Contractor, determine the action necessary and a price for additions or deletions shall be agreed upon prior to further drain installation. Where directed by the Engineer, test holes are to be dug to determine the extent of the affected area. Cost of test holes shall be considered an addition to the contract price.

C.12 ROCKS

The Contractor shall immediately contact the Engineer or Superintendent if boulders of sufficient size and number are encountered such that the Contractor cannot continue trenching with a tiling machine. The Engineer or Superintendent may direct the Contractor to use some other method of excavating to install the drain. The basis of payment for this work shall be determined by the Engineer and Drainage Superintendent.

If only scattered large stones or boulders are removed on any project, the Contractor shall haul same to a nearby bush or fenceline, or such other convenient location as approved by the Landowners(s).

C.13 BROKEN, DAMAGED TILE OR EXCESS TILE

The Contractor shall remove and dispose of off-site all broken (existing or new), damaged or excess tile or tiles. If the tile is supplied by the Municipality, the Contractor shall stockpile all excess tile in readily accessible locations for pickup by the Municipality upon the completion of the job.

C.14 TRIBUTARY DRAINS

Any tributary tile encountered in the course of the drain shall be carefully taken up by the Contractor and placed clear of the excavated earth. If the tributary tile drains encountered are clean or reasonably clean, they shall be connected into the new drain. Where existing drains are full of sediment, or contain pollutants, the decision to connect those drains to the new drain shall be left to the Engineer or Superintendent. Each tributary tile connection made by the Contractor shall be located and marked with a stake and no backfilling shall take place until the connection has been approved by the Engineer or Superintendent.

C.14 **TRIBUTARY DRAINS** (cont'd)

For tributary drains 150mm dia. or smaller connected to new tiles 250mm dia. or larger, and for 200mm dia. connected to 350mm dia. or larger, the Contractor shall neatly cut a hole in the middle of a tile length. The connections shall be made using a pre-fabricated adaptor. All other connections shall be made with pre-fabricated wyes or tees conforming to Boss 2000 split coupler or approved equal.

Where an open drain is being replaced by a new tile drain, existing tile outlets entering the ditch from the side opposite the new drain shall be extended to the new drain. All existing metal outlet pipes shall be carefully removed, salvaged, and left for the owner. Where the grade of the connection passes through the newly placed backfill in the ditch, the backfill material below the connection shall be thoroughly compacted and metal pipe of a size compatible with the tile outlet shall be installed so that a minimum length of 2 meters at each end is extending into undisturbed soil.

Where locations of tiles are shown on the drawings the Contractor shall include in his tender price, all costs for connecting those tiles to the new drain regardless of length.

Where tiles not shown on the drawings are encountered in the course of the drain, and are to be connected to the new drain, the Contractor shall be paid for each connection at the rate outlined in the Form of Tender and Agreement.

C.15 **OUTLET PIPES**

Corrugated steel pipe shall be used to protect the tile at its outlet. It shall have a hinged metal grate with a maximum spacing between bars of 40mm. The corrugated steel pipe shall be bevelled at the end to generally conform to the slope of the ditch bank and shall be of sufficient size that the tile can be inserted into it to provide a solid connection. The connection will then be grouted immediately.

The installation of the outlet pipe and the required rip-rap protection shall conform to the standard detailed drawing as noted on the drawing.

C.16 **CATCHBASINS AND JUNCTION BOXES**

.1 **Catchbasins**: Unless otherwise noted or approved, catchbasins shall be in accordance with O.P.S.D. 705.010, 705.030. All catchbasins shall include two - 150mm riser sections for future adjustments. All ditch inlet catchbasins shall include one 150mm riser section for future adjustments. The catchbasin top shall be a "Bird Cage" type substantial steel grate, removable for cleaning and shall be inset into a recess provided around the top of the structure. The grate shall be fastened to the catchbasin with bolts into the concrete. Spacing of bars on grates for use on 600mmx600mm structures shall be 65mm centre to centre. Spacing of bars on grates for use on structures larger than 600mmx600mm shall be 90mm with a steel angle frame.

The exact location and elevation of catchbasins shall be approved by the Road Authority or the Engineer/Superintendent. Catchbasins offset from the drain shall have "Boss 2000" 200mm diameter leads or approved equal unless otherwise noted and the leads shall have a minimum of 600mm of cover. The leads shall be securely grouted at the structures and the drain.

.2 **Junction Boxes**: Junction boxes shall be the precast type unless otherwise approved. Dimensions for precast junction boxes shall conform to those for catchbasins. The inside dimensions of the box shall be a minimum of 100mm larger than the outside diameter of the largest pipe being connected. The minimum cover over the junction box shall be 600mm. Benching to spring line shall be supplied with all junction boxes.

.3 **Connections**: Catchbasins and junction boxes shall not be ordered until elevations of existing pipes being connected have been verified in the field as indicated on the drawings. All connections shall be securely grouted at both the inside and outside walls of the structure.

.4 **Installation**: Where the native material is clay, all catchbasins shall be backfilled with an approved granular material placed and compacted to a minimum width of 300mm on all sides with the following exception. Where the native material is sandy or granular in nature it may be used as backfill. Filter cloth shall be placed between the riser sections of all catchbasins.

C.16 **CATCHBASINS AND JUNCTION BOXES** (cont'd)

Where the Contractor has over excavated or where ground conditions warrant, the structure shall be installed on a compacted granular base.

The Contractor shall include in his tender price for the construction of a berm behind all ditch inlet structures. The berm shall be constructed of compacted clay keyed 300mm into undisturbed soil. Topsoil shall be distributed to a 65mm thickness and seeded unless otherwise specified. The Contractor shall also include for regrading, shaping and seeding of road ditches for a maximum of 15 meters each way from all catchbasins.

C.17 **BLIND INLETS**

Where specified, blind inlets shall be installed along the course of the drain. In accordance with details on the drawings.

C.18 **GRASSED WATERWAY**

Topsoil to be stripped from construction area and stockpiled prior to construction of waterway. Waterway to be graded into a parabolic shape to the width shown on the drawings. Topsoil to be relevelled over the waterway and other areas disturbed by construction.

Waterway to be prepared for seeding by harrowing and then seeded by drilling followed by rolling. Seeding rate to be 85 Kg/Ha with the following mixture:

- 30% Canon Canada Bluegrass
 - 25% Koket Chewings Fescue
 - 30% Rebel Tall Fescue
 - 15% Diplomat Perennial Rye
- Plus #125 Birdsfoot Trefoil (25% of Total Weight)

C.19 **BACKFILLING EXISTING DITCHES**

The Contractor shall backfill the ditch sufficiently for traversing by farm machinery. If sufficient material is not available from the old spoil banks to fill in the existing ditch, the topsoil shall be stripped and the subsoil shall be bulldozed into the ditch and the topsoil shall then be spread over the backfilled ditch unless otherwise specified on the contract drawings. The Contractor shall ensure sufficient compaction of the backfill and if required, repair excess settlement up to the end of the warranty period. The final grade of the backfilled ditch shall provide an outlet for surface water.

C.20 **RECOMMENDED PRACTICE FOR CONSTRUCTION OF SUBSURFACE DRAINAGE SYSTEM**

Drainage guide for Ontario, Ministry of Agriculture, Food and Rural Affairs Publication Number 29 and its amendments, dealing with the construction of Subsurface Drainage systems, shall be the guide to all methods and materials to be used in the construction of tile drains except where superseded by other specifications of this contract.

The requirements of licensing of operators, etc. which apply to the installation of closed drains under the Tile Drainage Act shall also be applicable to this contract in full unless approval otherwise is given in advance by the Engineer.

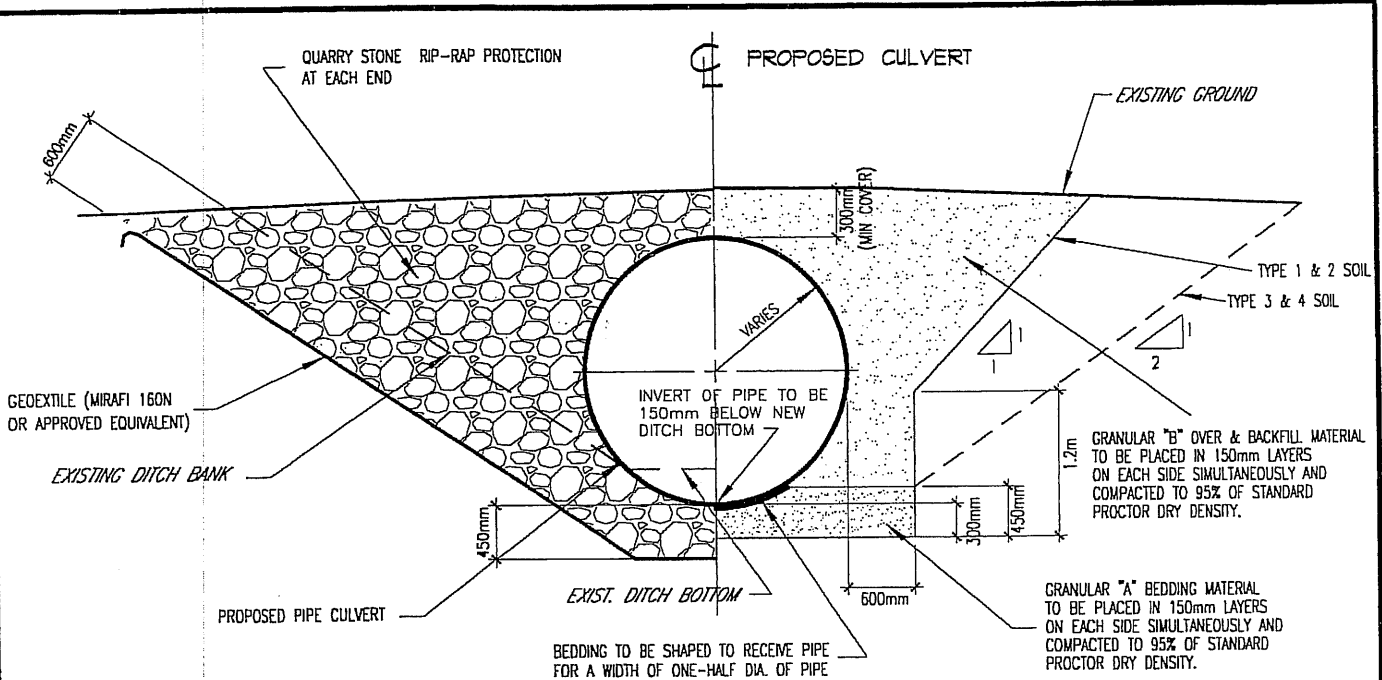

HALF ELEVATION

HALF SECTION

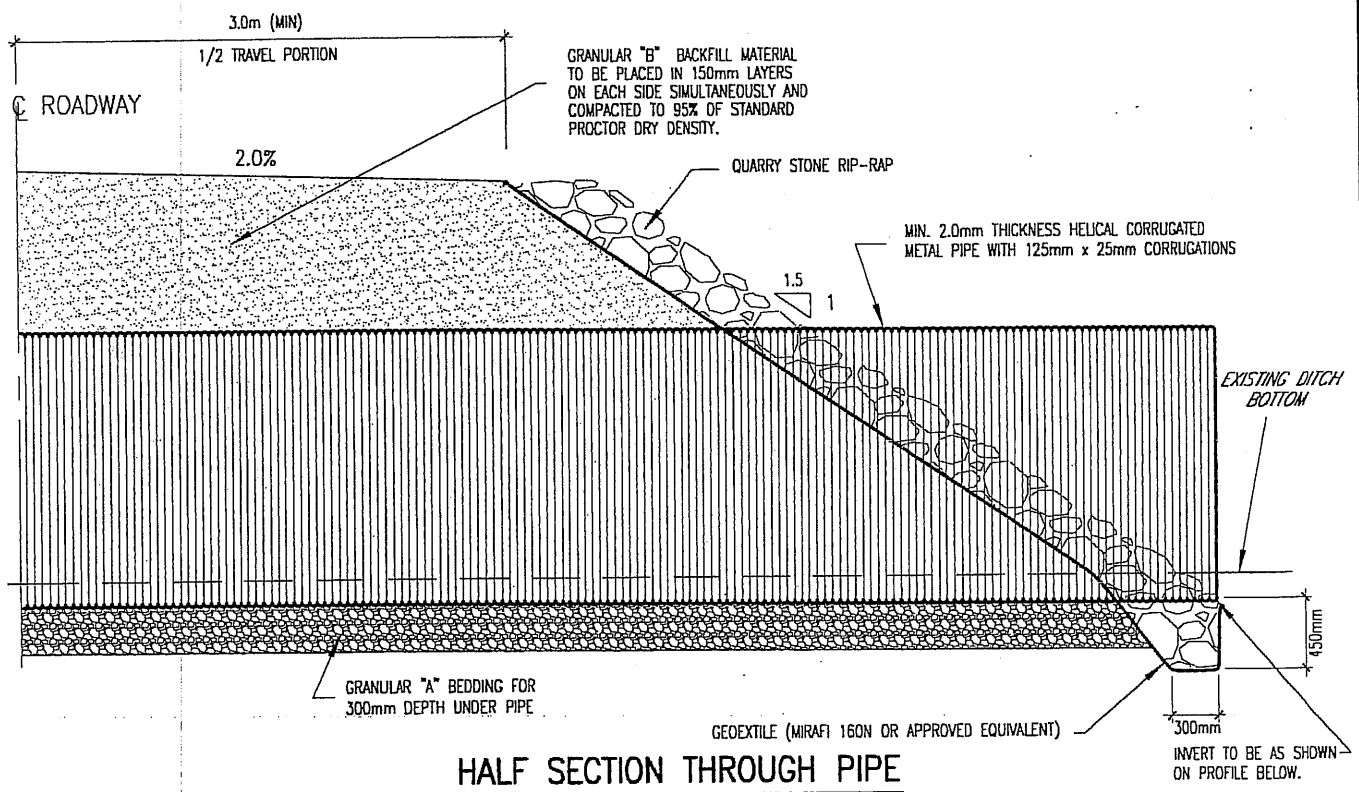

HALF SECTION THROUGH PIPE

NOTES

- 1) WHERE THE CULVERT IS TO BE INSTALLED IN POOR SOIL CONDITIONS, THE BEDDING MATERIAL SHALL BE 19mm CRUSHED STONE COMPLETELY WRAPPED IN GEOTEXTILE SUCH AS MIRAFI 160N OR APPROVED EQUIVALENT.

TYPICAL FARM CULVERT INSTALLATION DETAIL		
Scale: N.T.S.	Approved by: M.P.D.	Date: January 1983
Drawn by: jk		Revised: November 2000
ELEVATION & SECTION		STANDARD DETAILED DRAWING No. 01
SPRIET ASSOCIATES LONDON LIMITED CONSULTING ENGINEERS ARCHITECTS		

1. TILE TO BE BUTT END TO SEWER PIPE AND WRAPPED WITH GEOTEXTILE
2. TILE INSERTED 150mm INTO C.S.P. AND TO BE JOINT GROUTED

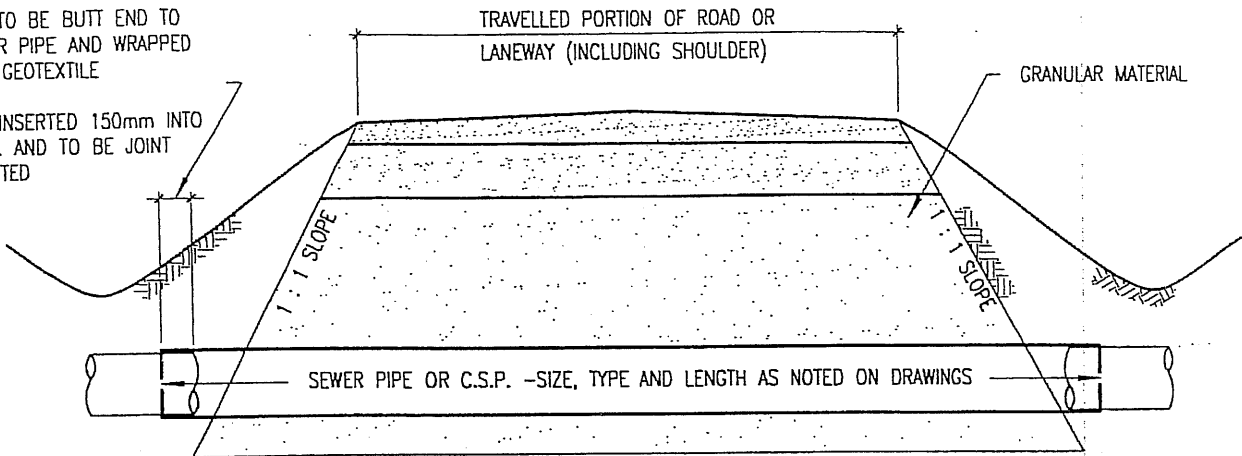

SECTION THROUGH PIPE

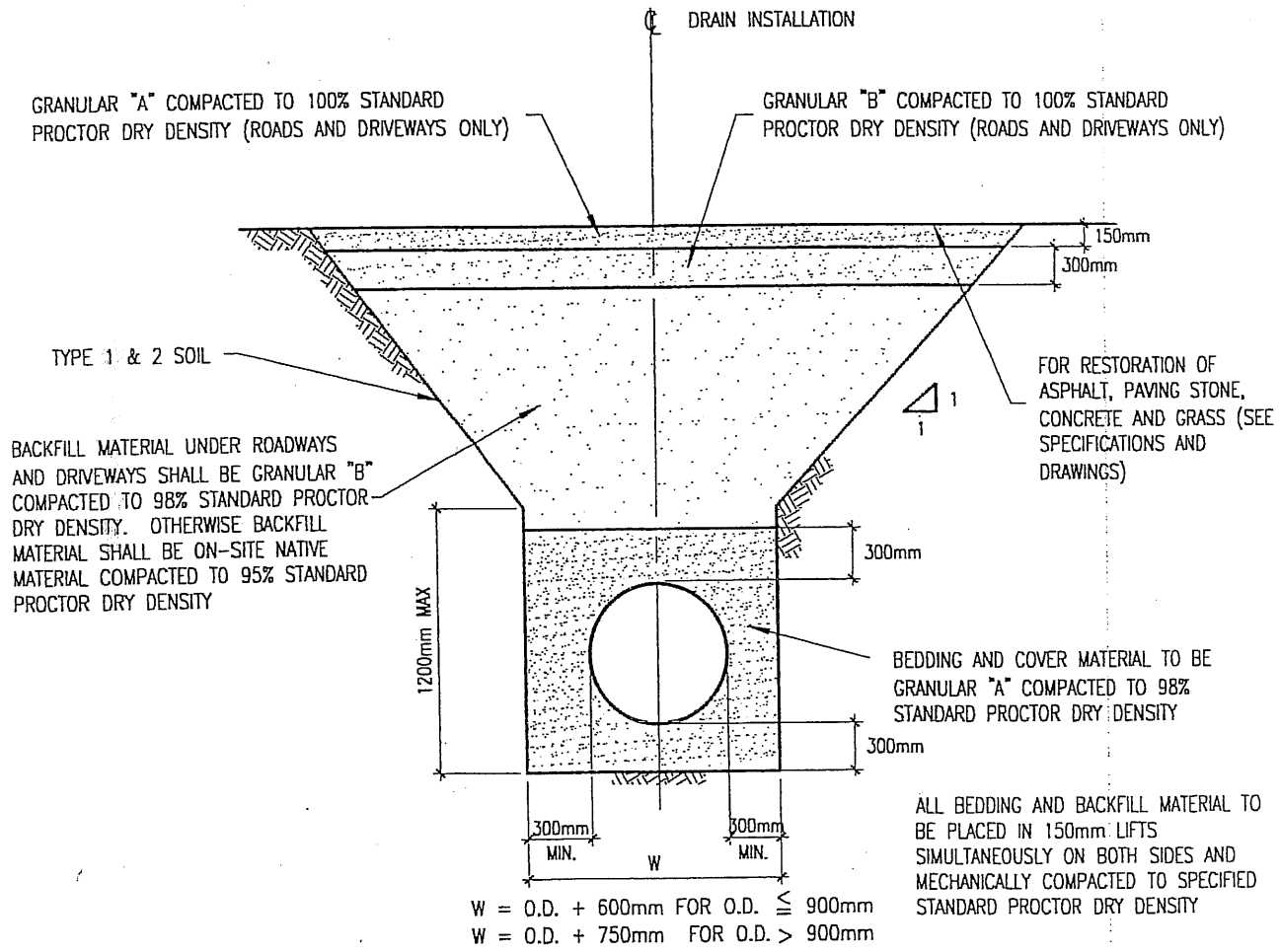

CROSS SECTION

TYPICAL INSTALLATION DETAIL FOR FLEXIBLE PIPE		
Scale: N.T.S.	Approved by: M.P.D.	Date: January 1983
Drawn by: jk		Revised: November 2000
ELEVATION & SECTION		STANDARD DETAILED DRAWING
SPRIET ASSOCIATES LONDON LIMITED CONSULTING ENGINEERS ARCHITECTS		No. 02

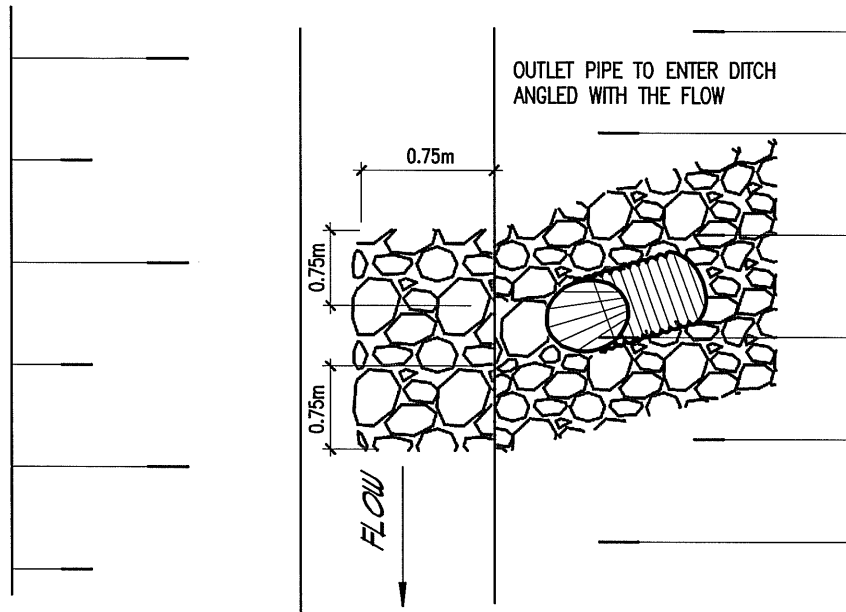

PLAN

NOTES

1. WHERE THE DISTURBED AREA EXCEEDS THE MIN. WIDTHS, RIP-RAP TO EXTEND TO A MIN. OF 600mm BEYOND THE DISTURBED AREA

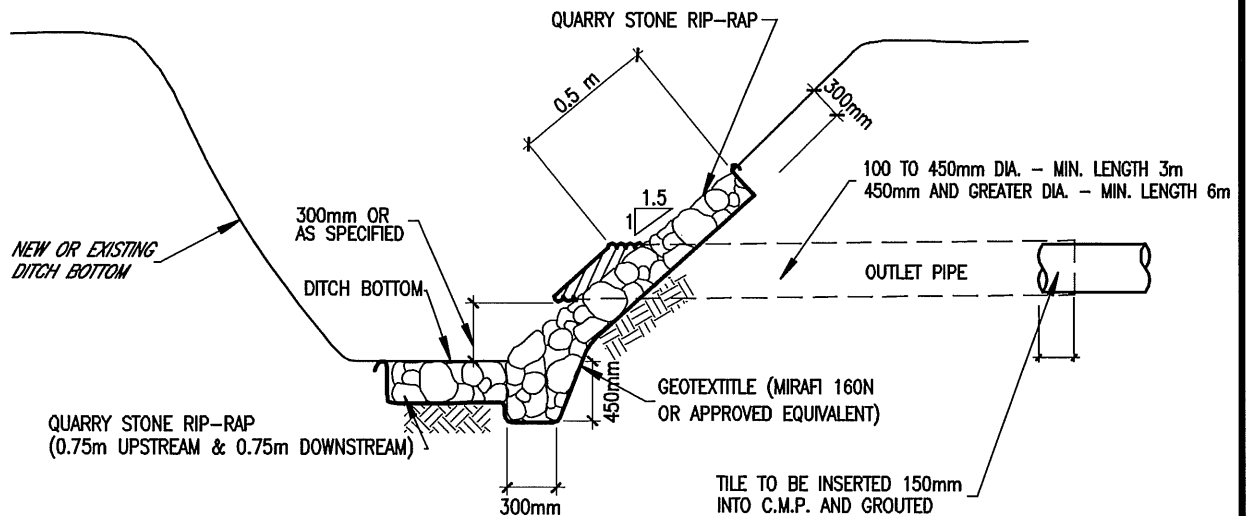

TYPICAL OUTLET RIP-RAP

NOTES

1. RIP-RAP TO EXTEND UP THE SLOPE 0.5 METER ABOVE TOP OF OUTLET
2. WHERE SURFACE RUN ENTERS DITCH AT OUTLET PIPE, A ROCK CHUTE SHALL BE INSTALLED (SEE S.D.D. No. 05) AND PIPE SHALL BE INSTALLED ADJACENT TO ROCK CHUTE.
3. HINGED RODENT GATE TO BE AFFIXED TO END OF OUTLET PIPE.

TYPICAL OUTLET RIP-RAP THROUGH SIDE SLOPE OF DITCH

Scale: N.T.S.	Approved by:	Date: November 2000
Drawn by: jk	M.P.D.	Revised: January 2009

PLAN & SECTION

SPRIET ASSOCIATES LONDON LIMITED
CONSULTING ENGINEERS ARCHITECTS

STANDARD
DETAILED
DRAWING
No. 03

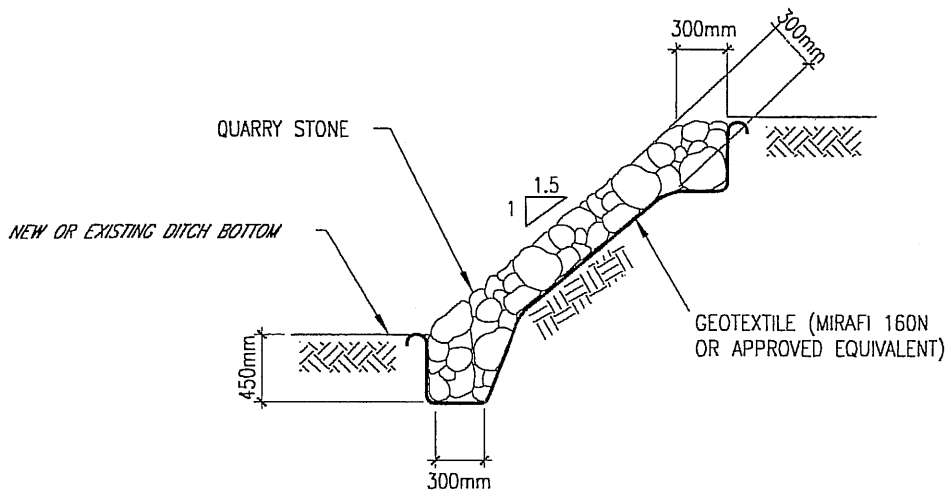

TYPICAL DITCH BANK RIP-RAP

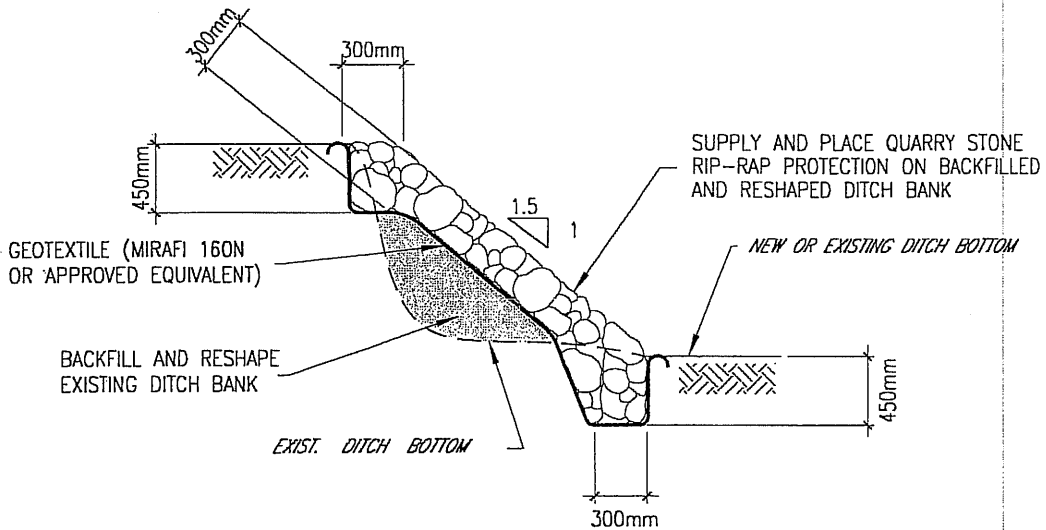

**TYPICAL DITCH BANK RIP-RAP
WITH BACKFILLING OF WASHOUT**

TYPICAL DITCH BANK RIP-RAP DETAILS

Scale: N.T.S.	Approved by:	Date: July 2000
Drawn by: jk	M.P.D.	Revised: November 2000

SECTIONS

SPRIET ASSOCIATES LONDON LIMITED
CONSULTING ENGINEERS ARCHITECTS

STANDARD
DETAILED
DRAWING
No. 04

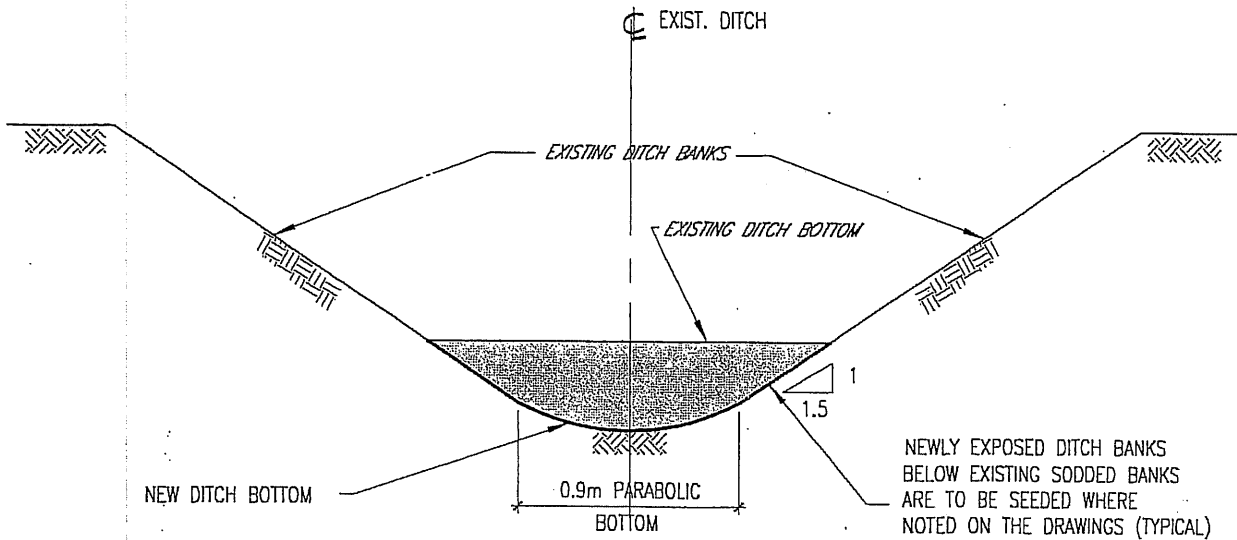

TYPICAL DITCH BOTTOM CLEANOUT

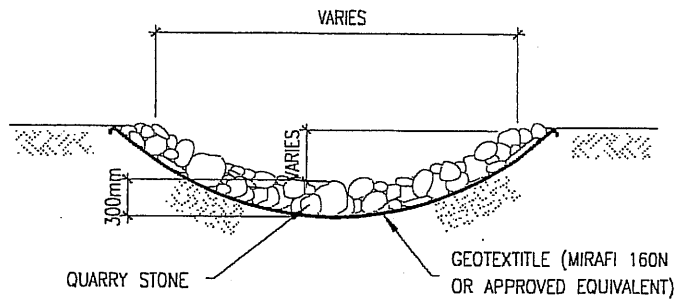
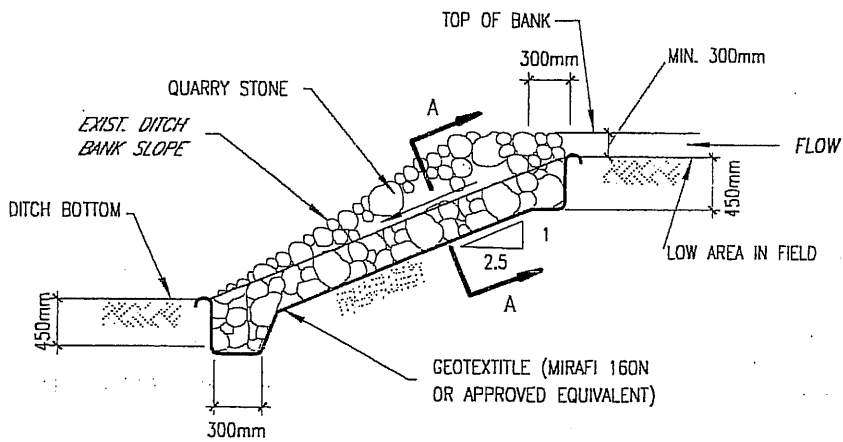

SECTION A-A

TYPICAL ROCK CHUTE

TYPICAL DITCH BOTTOM CLEANOUT TYPICAL ROCK CHUTE CONSTRUCTION		
Scale: N.T.S.	Approved by:	Date: November 2000
Drawn by: jk	M.P.D.	Revised:
SECTIONS		STANDARD DETAILED DRAWING No. 05
SPRIET ASSOCIATES LONDON LIMITED CONSULTING ENGINEERS ARCHITECTS		