

--	--

TO:	CHAIR AND MEMBERS BUILT AND NATURAL ENVIRONMENT COMMITTEE SEPTEMBER 26, 2011
FROM:	JOHN V. LUCAS, P. Eng. ACTING DIRECTOR, ROADS AND TRANSPORTATION
	ACCESS MANAGEMENT & TRANSPORTATION IMPACT ASSESSMENT GUIDELINES

RECOMMENDATION

That, on the recommendation of the Acting Director, Roads and Transportation,

- a) The following information report relating to Access Management Guidelines and Transportation Impact Assessment Guidelines **BE RECEIVED** for information; and
- b) The attached DRAFT Access Management Guidelines and Transportation Impact Assessment Guidelines **BE CIRCULATED** to the London Development Institute, the London Engineering & Area Planning Consultants, the London Transit Commission, and other interested parties for review and comment.

BACKGROUND

Purpose:

The purpose of this report is to provide the Built and Natural Environment Committee with a brief description of the attached guideline documents, the rationale for the essential need for these technical documents and a recommendation on how to receive technical comment on them.

Context:

Draft Access Management Guidelines (herein referred to as "AMG") and Transportation Impact Assessment Guidelines (herein referred to as "TIA") have been in use by City staff and the development community for the past few years. These guidelines provide direction to the applicants and their consultants in the preparation of comprehensive submissions. The AMG & TIA technical documents identify the required works for the applicants when completing an Environmental Assessment, Area Plan, Transportation Impact Assessment, or any other form of transportation study. Official Plan Policies that provide direction to develop guidelines are included in Appendix "C".

Discussion:

What is Access Management?

Transportation Association of Canada defines access management as "... a comprehensive process through which a provincial or municipal jurisdiction effectively manages the provision of access to the public road system for new development or re-development. The primary objective is to provide safe and orderly access consistent with the functional and operational requirements of the public roads and the accessibility needs of the adjacent land uses".

The purpose of the AMG (attached herein Appendix "A") is to provide a framework for access control that will maintain a high level of service for through-traffic, while providing reasonable access to abutting properties. The overall goals of the guideline are to reduce collisions, alleviate traffic congestion, reduce energy consumption, preserve the long term integrity of the traffic movement function, protect pedestrians and promote an aesthetically pleasing arterial corridor.

--	--

It is recognized that other guideline initiatives are underway for Placemaking and Urban Design. In considering access management guidelines and policies, it is important to take into account transportation operational and safety goals and the objectives of the Placemaking vision. Access management policies should serve to deliver the broader vision and objectives of the City, including mobility, safety, and placemaking. Access management is not applied and designed for auto traffic only; it is also for commercial vehicles, transit vehicles, cyclists, pedestrians, and persons with special mobility needs. The draft guideline was prepared and reviewed internally to be compatible with Placemaking initiatives.

What is a Transportation Impact Assessment?

The goal of a TIA (attached herein Appendix “B”) is to identify how multiple modes of transportation (automobiles, public transit, walking, cycling, etc.) will work together in a proposed development and identifies what infrastructure is required to support the development. The TIA should demonstrate that the transportation impacts of a proposed development or redevelopment will be manageable and that the transportation aspects of the proposal are consistent with the objectives and policies of the City of London.

The TIA evaluates the current road network and traffic patterns in the area and addresses what impact the new development will have on the roads and traffic patterns. It should include the classification of both external and internal roads while identifying required changes to existing infrastructure (e.g., road widening, signal timing, pedestrian routes, etc.) as a result of the additional vehicle, cycling, transit and pedestrian trips generated by the new development.

Progress to Date

Access management strategies and levels of control are directly related to the intended function and classification of the road, in particular access control is essential along arterial roads where the mobility of the through traffic is a priority. In recognition of their significance, the Official Plan refers to both of the AMG & TIA documents in Section 18 -Transportation. The OP notes that Council shall adopt these guidelines pursuant to Section 19.2.2 of the Official Plan.

The noted guidelines were circulated internally to the Planning Department and DABU to get their perspectives and comments on the documents. This was followed by an internal meeting to discuss and finalize all the comments received to include in this report. It should be noted that the attached documents have accommodated all the comments received to date.

Next Steps

- Circulate the guideline documents to the London Development Institute, the London Engineering & Area Planning Consultants, and the London Transit Commission, and receive their comments.
- Consider the comments in updated versions of the guidelines.
- Report back to the Committee as part of a public meeting to seek approval and Council adoption of the AMG and TIA Guidelines pursuant to Section 19.2.2 of the Official Plan

Acknowledgements:

This report was prepared with the assistance of Maged Elmadhoon, Manager, Traffic Engineering and Transportation Planning within the Transportation Planning and Design Division.

--	--

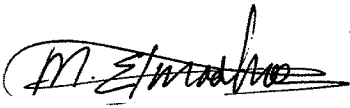
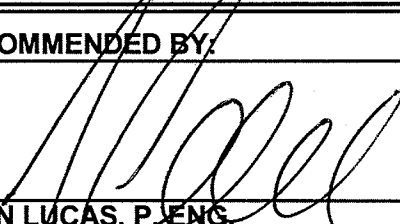
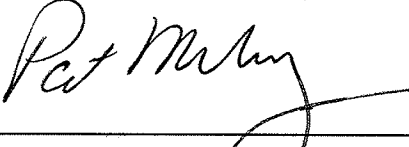
PREPARED BY:	RECOMMENDED BY:
	
MAGED ELMADHOON, M.ENG., P. ENG TRANSPORTATION PLANNING & DESIGN, ENVIRONMENTAL AND ENGINEERING SERVICES	JOHN LUCAS, P. ENG. ACTING DIRECTOR, ROADS AND TRANSPORTATION, ENVIRONMENTAL AND ENGINEERING SERVICES
REVIEWED & CONCURRED BY:	
	
PAT MCNALLY, P. ENG EXECUTIVE DIRECTOR, PLANNING, ENVIRONMENTAL AND ENGINEERING SERVICES DEPARTMENT	

Z:\R&T\2011\Sept 26\AMG-TIA Guidelines.docx

Attach: Appendix 'A' – Access Management Guidelines
 Appendix 'B' – Transportation Impact Assessment Guidelines
 Appendix "C" – Official Plan excerpts

c.c. J. Braam
 J. Fleming
 D. Ailles

Agenda Item # Page #

--	--

Appendix 'A'

Access Management Guidelines



London
CANADA

City of London

FINAL DRAFT

ACCESS MANAGEMENT GUIDELINES

JUNE 2011

ACKNOWLEDGEMENTS

The Access Management Guidelines were originally prepared by IBI Group in 2007. Dillon Consulting Limited then prepared the City of London's Access Management Policy in March 2009, which included the Access Control By-law and updated the Access Management Guidelines accordingly. Since then, additional modifications have been incorporated by City staff. These guidelines are the summation of contributions made by all parties. The City of London gratefully acknowledges IBI Group and Dillon Consulting Limited for their assistance and technical input provided.

TABLE OF CONTENTS

INTRODUCTION	1
1. ACCESS LAYOUT.....	3
1.1. Road Classification System.....	3
1.2. Subdivision Road Network	4
1.3. Number of Accesses	5
1.4. Access Connection Spacing.....	5
1.4.1 Signalized Intersections / Driveways	5
1.4.2 Major Access Connections	6
1.4.3 Minor Access Connections	7
1.4.3.1 At Stop Controlled Intersection	7
1.4.3.2 At Signal Controlled Intersection.....	8
1.4.3.3 Minimum Driveway Separation Distance	8
1.5. Interchange Access Offset Spacing	9
1.6. Capacity and Level-of-Service.....	11
1.7. Alignment of Opposing Accesses.....	11
1.8. Angle of Access Centreline	11
1.9. Site Inter-Connection.....	12
1.10. Joint Access / Internal Connections	12
1.11. Grade	14
1.12. Sight Line Distance	15
1.13. Access Widths.....	16
1.14. Radii	18
1.15. Curb Radius – No Encroachment.....	18
1.16. Curb Return Design.....	19

TABLE OF CONTENTS

2.	TURNING RESTRICTIONS	20
2.1.	Operating Requirements	20
2.2.	Inbound Left-Turn Restriction.....	21
2.3.	Left-Turn Egress Restriction.....	21
2.4.	Rights-In / Rights-Out.....	22
2.4.	Rights-In / Rights-Out "Pork Chop".....	22
3.	ROADWAY FEATURES	23
3.1.	Left Turn Lane.....	23
	3.1.1 Volume Warrant	23
	3.1.2 Collision Warrant	23
3.2.	Right-Turn Lane	23
3.3.	Medians.....	24
3.4.	Signal Warrant.....	24
3.5.	Bus Bays	24
	3.5.1 Structure.....	25
	3.5.2 Geometry	25
3.6.	Sidewalks	25
	3.6.1 Location.....	25
	3.6.2 Geometry	25
3.7.	Bicycle Paths.....	26
4.	PARKING OPERATIONS	27
4.1.	Clear Throat Distance	27
4.2.	Lay-Bys	28
4.3.	Turnaround Areas	29
4.4.	Drive-Throughs.....	30
4.5.	Loading Docks.....	30
4.6.	End Island Treatments	31

LIST OF EXHIBITS

Exhibit 1-1: Road Classification System	3
Exhibit 1-2: Subdivision Road Network	4
Exhibit 1-3: Corner Clearance	7
Exhibit 1-4: Arterial Minimum Driveway Spacing	9
Exhibit 1-5: Minimum Spacing for a Parclo A-4 Interchange	10
Exhibit 1-6: Centreline Alignment	11
Exhibit 1-7: Angle of Intersection	12
Exhibit 1-8: Joint Access	14
Exhibit 1-9: Plan View of an At-Grade Landing	14
Exhibit 1-10: Profile View of an At-Grade Landing	15
Exhibit 1-11: Driveway Layouts	16
Exhibit 2-1: Inbound Left Turn Restriction to Driveways	21
Exhibit 2-2: Left Turn Egress Restriction from Driveway	21
Exhibit 2-3: Both Left Turns Restricted	22
Exhibit 4-1: Minimum Distance to a Parking Space	28
Exhibit 4-2: Minimum Distance to a Parking Aisle	28
Exhibit 4-3: Lay-by and Passenger Drop-off Zone	29
Exhibit 4-4: Turnaround Area for Passenger Vehicle	30
Exhibit 4-6: Loading and Courier Areas	31

LIST OF TABLES

Table 1-1: Spacing Between Signalized Intersections / Driveways	6
Table 1-2: Spacing from Signalized Intersections	6
Table 1-3: Minimum Spacing Between Major Access Connections	6
Table 1-4: Minimum Spacing for Highway Interchange with Two-Lane Crossing Road	10
Table 1-5: Driveway Grades and Grade Changes	15
Table 1-6: Driveway Dimensions	17
Table 4-1: Clear Throat Distances – Parking Facilities	27

LIST OF APPENDICES

Appendix A: Turning Template
Appendix B: End Island Treatments

INTRODUCTION

This document recommends guidelines for Access Management in the City of London. The purpose of the guidelines are to provide a framework for access control that will maintain a high level of service for through-traffic, while providing reasonable access to abutting properties. The overall goals of the guideline are to reduce collisions, alleviate traffic congestion, reduce energy consumption, preserve the long term integrity of the traffic movement function, and promote an aesthetically pleasing arterial corridor. These guidelines are intended to manage the provision of access to the public road system for new development or redevelopment, and proactively through corridor reconstruction. The recommended guidelines are based on an industry scan of other jurisdictions and governing bodies.

In this document, the words "shall", "should" and "may" are used to describe specific conditions concerning these guidelines. To clarify the meaning intended in this document by these words, the following definitions shall apply:

1. **SHALL or MUST** - a mandatory condition. This falls under the categories of "Legal Requirement(s)", or "Interpretation". Where certain requirements in the design or application of the device are described with the "shall" stipulation, it is mandatory when an installation is made that these requirements be met.
2. **SHOULD** - an advisory condition. This falls under the category of "Recommended Practice". Where the word "should" is used, it is considered to be advisable usage, recommended but not mandatory.
3. **MAY** - a permissive condition. This falls under the category of "Guideline". No requirement for design or application is intended.

List of Guidelines

The following lists the guidelines that are addressed in this document:

- Access Layout;
- Turning restrictions;
- Roadway features; and
- Parking operations.

Documentation Scan

The following documents were reviewed in performing the industry scan:

- Ontario Highway Traffic Act Regulations;
- Manual of Uniform Traffic Control Devices for Canada TAC, 4th Edition;
- Manual on Uniform Traffic Control Devices, FHWA;
- Institute of Transportation Engineers (ITE) Traffic Engineering Handbook, 5th Edition;

- ITE Transportation and Land Development, 2nd Edition.

Jurisdiction Scan

- Region of Durham;
- Region of Halton;
- City of Toronto;
- City of Calgary;
- City of Edmonton;
- City of Regina;
- City of Saskatoon.

Reference Documents

The following is a list of reference documents that should be consulted in conjunction with these guidelines:

City of London Documents:

- Site Plan Control Area By-law;
- Subdivision and Development Manual;
- Transportation Design Specifications;
- The Official Plan;
- Transportation Impact Study Guidelines.

External Documents:

- TAC – Geometric Design Guide for Canadian Roads.

1. ACCESS LAYOUT

1.1. Road Classification System

Roadway networks are based on a hierarchical system of interconnected roadways that provide for a balance between the need to safely and efficiently move goods and people, and minimize conflicts with adjacent land uses. For access management purposes, road function is divided into five categories: Freeway/Expressway/Parkway, Arterial, Collector, Local, and Window. The purpose of this classification system is, in part to provide a grouping of roads according to the type and degree of service they provide.

The function of each road type is as follows:

Freeway/Expressway/Parkway:

- Function is to service through traffic needs
- Full access control (no access) to abutting lands
- Normally connects with Arterial, Expressway/Parkway, and/or Freeway

Arterial:

- Primary function is to service through traffic, secondary function is to provide access to land
- High degree of access control, restricted and limited direct access to abutting lands
- Normally connects with Collector, Arterial, Expressway/Parkway, and/or Freeway

Primary/Secondary Collector:

- Function is to serve through traffic and to provide access to land
- Intermediate degree of access control, generally allow access to abutting properties
- Normally connects with Window, Local, Collector, and/or Arterial

Local:

- Function is to provide access to land
- Allow full access to abutting properties
- Normally connects with Window, Public lane, Local, and/or Collector

Window Street:

- Function is to provide single loaded access to individual properties
- Normally connects with secondary collector or local roadways

Exhibit 1-1: Road Classification System

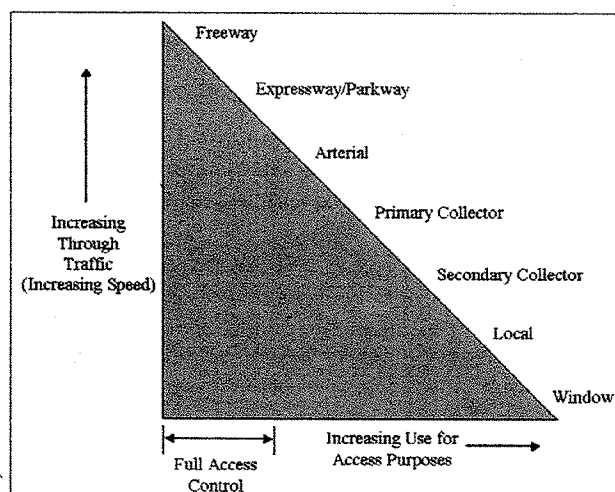

1.2. Subdivision Road Network

A Plan of Subdivision usually entails the redevelopment of a substantial parcel of land such that a local road network is required to service the lands. The development of a local road network is encouraged so that traffic activities are organized at specific access points.

Practice

Direct access to a new parcel of land must be obtained from a local road network that connects to the arterial road. Direct access to an arterial road must be minimized, and therefore, all proposed driveways must be justified. In addition, the standards as set out in the Guidelines also apply to the provision of a new public road connecting to the arterial road as shown in Exhibit 1-2.

It is important that volumes be very low and the speeds be low on local residential streets. These can be limited by assigning a maximum length for cul-de-sac* and local streets:

- The City suggested maximum for cul-de-sac is 215 metres; Suggested maximums for other local streets are 395 metres and 50 to 75 dwellings.

* Cul-de-sacs are discouraged and are implemented only when other options are not available.

References

ITE Transportation and Land Development, Chapter 13: Residential Neighbourhood Streets, page 24.

Exhibit 1-2: Subdivision Road Network

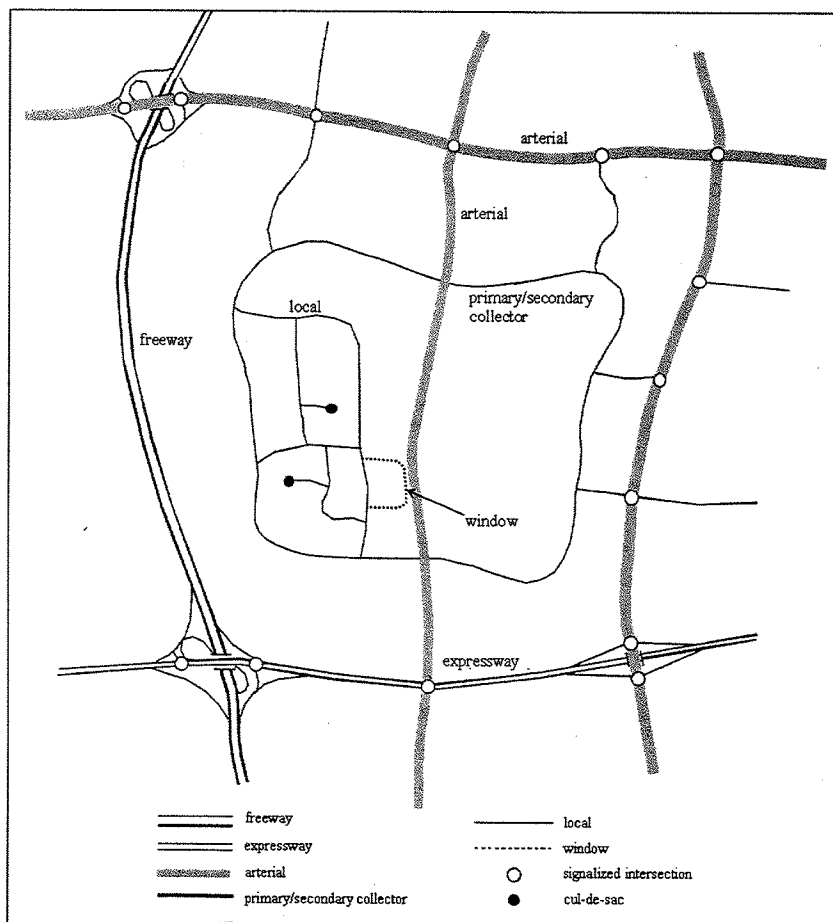

1.3. Number of Accesses

The number of new driveways that will be permitted to a specific site depends on several factors: the density and type of land use, the classification of the adjacent roadway, the type of operations that will be permitted at the new driveway(s), and the location and operating activity of existing driveways or local road connections. The implementation of joint accesses and/or common internal drives is encouraged.

Practice

Direct access to an arterial road must be minimized, and therefore, all proposed driveways must be justified. The developer must first pursue alternate access arrangements as follows:

- Obtain access from the collector or local road network;
- Attempt to negotiate joint accesses and/or common internal drive arrangement with adjacent property owners;
- Develop private "commercial service roads" on-site, with adjacent property owners, to manage traffic circulation needs on-site.

Joint accesses are encouraged and/or may be required to minimize the number of driveways onto arterial roads. The City may place a 0.3 metres (1foot) reserve along the edge of these road allowances to prevent the addition of driveways.

The preference of the City is for one driveway per development to an abutting arterial roadway. Where development is consolidating existing parcels, consolidation and/or removal of existing driveways may be required. Where development is being undertaken in a phased implementation, temporary driveways may be permitted until such time that the ultimate access to the development has been made, at which time the temporary driveway shall be removed. Additional driveway access to the arterial road network will be subject to special considerations such as traffic analyses justifying the need for additional access to improve safety, flow and/or circulation and shall meet the spacing requirements set forth in Section 1.4 of this guideline.

1.4. Access Connection Spacing

There are three types of access connections to City of London roads:

- Signalized intersections / signalized driveways
- Major access connections (intersections and significant driveways)
- Minor access connections (driveways)

All significant driveway access connections shall meet or exceed the connection spacing requirements of the appropriate road class as specified in Tables 1-1 to 1-3. A significant driveway is defined as a driveway serving a land use or development block that generates a high volume of traffic during traffic peak periods. (e.g. traffic volume in excess of 100 vph).

1.4.1 Signalized Intersections / Driveways

Table 1-1 contains the desirable and minimum allowable spacing for signalized intersections on City of London roadways.

Expressways are to be grade separated with freeways, other expressways or arterial roads. At-grade intersections with arterial roads may occur at widely spaced intervals greater than or equal to 800 m. For urban divided arterial roadways, the desirable signal spacing may be reduced from 800 m to 400 m if the

subject signal, to the satisfaction of the City Engineer, maintains the capacity and safety of the arterial corridor, or if the signal does not impact signal progression excessively.

On arterial and collector roadways, the signal spacing may only be reduced if substantiated through the submission of a comprehensive corridor analysis and transportation impact study, analysing all possible alternatives and taking into consideration land use and community factors.

Table 1-1: Spacing Between Signalized Intersections / Driveways

<i>Class</i>	<i>Desirable</i>	<i>Minimum</i>
Expressways	Grade Separated	800 m
Rural Arterial	800 m	400 m
Divided Urban Arterial	800 m	400 m
Urban Arterial	400 m	215 m
Primary Collector	300 m	215 m

1.4.2 Major Access Connections

- a) Spacing from signalized intersections.

On collector and urban arterial roadways, the minimum spacing between a major access point and a signalized intersection is 215 m. This is to allow for the potential future signalization of the major access connection without compromising the minimum spacing requirements between signalized intersections, as per Table 1-2.

Table 1-2: Spacing from Signalized Intersections

<i>Class</i>	<i>Desirable</i>	<i>Minimum</i>
Expressways	N/A	N/A
Rural Arterial	800 m	400 m
Divided Urban Arterial	800 m	400 m
Urban Arterial	300 m	215 m
Primary Collector	300 m	215 m
Collector	N/A	215 m

- b) Spacing between major access connections.

The following minimum spacing guidelines apply to all major access connections:

Table 1-3: Minimum Spacing Between Major Access Connections

<i>Class</i>	<i>Full Moves</i>	<i>Right-in / Right-out</i>
Expressways	N/A	N/A
Rural Arterial	300 m	150 m
Divided Urban Arterial	200 m	75 m
Urban Arterial	150 m	75 m
Primary Collector	100 m	60 m

Note:

- i. Intersection/driveway spacing shall be measured from centre-line to centre-line.
- ii. Additional spacing over and above that set forth in Table 1-3 may be required if determined that there is insufficient left turn queue storage or weave manoeuvre area between adjacent intersections. This determination shall be made under peak conditions.
- iii. Major access connections are not permitted on Expressway roadways.

Reference

York Region Access Guideline for Regional Roads

1.4.3 Minor Access Connections

1.4.3.1 At Stop Controlled Intersection

Practice

A minimum corner clearance of 60 metres should be provided from the centre line of an arterial intersection and the centre line of a proposed driveway at a stop-controlled intersection. If this minimum clearance cannot be obtained, then the driveway or access should be placed at the far limit of the property. If that is the case, a traffic analysis has to be conducted, with traffic volumes projected 5 years into the future.

"Where minimum corner clearance cannot be met, directional prohibitions: right-in and right-out, or right in, or right-out may be implemented and/or required."

Additional clearance may be required to ensure that the driveway movements do not conflict with intersection movements. In addition, a full movement driveway must be clear of the start of the taper for the left turn storage lane. Exhibit 1-3 illustrates the Corner Clearance.

Exhibit 1-3: Corner Clearance

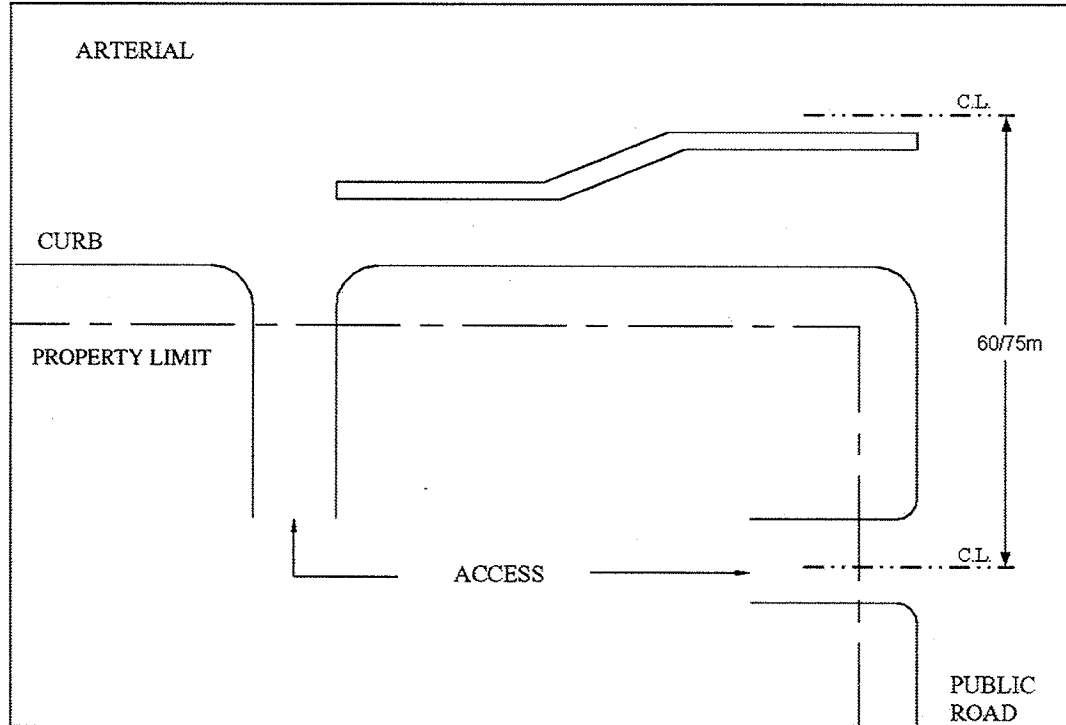

Typically, a further restriction to this practice is made in the case of vehicle service stations ("gas stations"). Only one driveway is desirable on an arterial road, located at the edge of the property. The permitted movements are typically limited to right in/right out.

References

Metro Toronto Transportation Access Management Guidelines
Transportation and Land Development, Chapter 6: Access Locations for Site Development, page 6-25.

1.4.3.2 At Signal Controlled Intersection

Practice

A minimum corner clearance of 75 metres should be provided from the centre line of an arterial signalized intersection and the centre line of a proposed driveway adjacent a traffic signal-controlled intersection. If this minimum clearance cannot be obtained, then the driveway or access clearance should be placed at the far limit of the property. Furthermore, a traffic analysis has to be conducted with traffic volumes projected 5 years into the future, to address potential impacts on traffic operations.

"Where minimum corner clearance cannot be met, directional prohibitions: right-in and right-out, or right in, or right-out may be implemented and/or required."

Additional clearance may be required to ensure that the driveway movements do not conflict with intersection movements. In addition, a full movement driveway must be clear of the start of the taper for the left turn storage lane. Exhibit 1-3 illustrates the Corner Clearance. These guidelines apply to both public roads and private roads connecting to a signalized intersection.

Typically, an exception to this practice is made in the case of vehicle service stations ("gas stations"). Only one driveway is desirable on an arterial road, located at the edge of the property. The permitted movements are typically limited to right in/right out.

References

Metro Toronto Transportation Access Management Guidelines
Transportation and Land Development, Chapter 6: Access Locations for Site Development, page 6-25.

1.4.3.3 Minimum Driveway Separation Distance

The spacing of driveways is related to the number and location of existing adjacent driveways and the number of new unsignalized intersections (driveways) proposed to serve the subject site. Two key factors influence minimum spacing requirements: traffic activity to/from the arterial road and the specific design elements of the proposed driveway. Spacing criteria seek to achieve the following objectives:

- Clearly identify which property the driveway is serving;
- Minimize the conflict areas between vehicles that enter/exit the proposed driveway, existing driveways, and the arterial road;
- Maintain usable boulevards between driveways for the placement of utilities, traffic control devices and road amenities.

Practice

- Strict applications of traffic engineering criteria may place desirable spacing requirements at 150 metres along an arterial roadway. However, this type of spacing is mostly unacceptable in several urban and suburban environments. Typically, a spacing of 30 – 60 metres is used along an arterial or primary collector roadway. The minimum spacing between two driveways should be the sum of the minimum curb radii (R), and a 10-metre tangent (T). If the 10-metre tangent requirement cannot be achieved, provisions for a joint access connection should be considered. The radii are determined by the type of land use, as outlined in Exhibit 1-11. Exhibit 1-4 illustrates arterial minimum driveway spacing.

Exhibit 1-4: Arterial Minimum Driveway Spacing

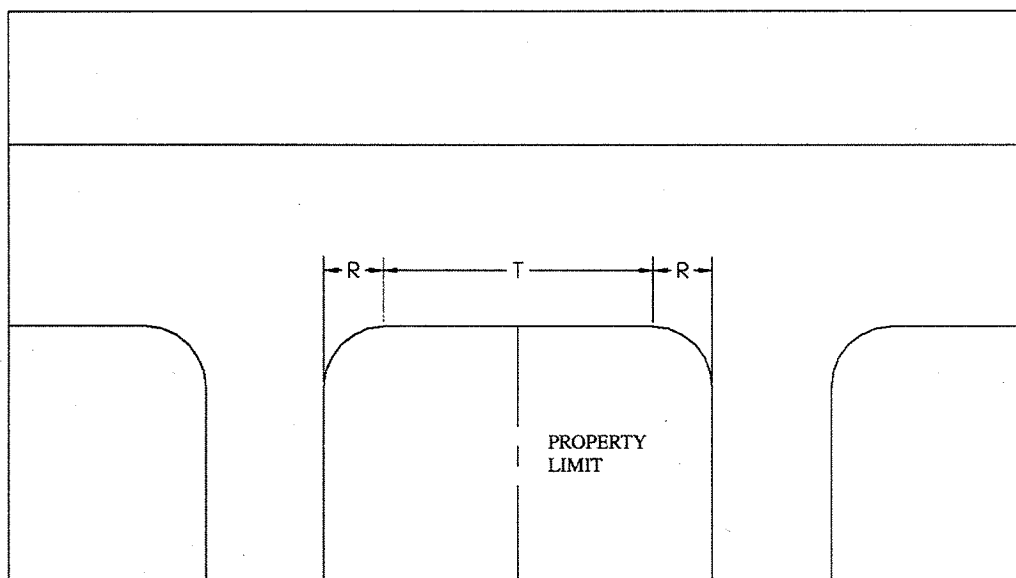

References

Traffic Engineering Handbook, Chapter 10, Page 316
Part 2 of the TAC Geometric Design Guide for Canadian Roads (1999), Section 3.2.9.8
Metro Toronto Transportation Access Management Guidelines

1.5. Interchange Access Offset Spacing

Interchanges provide the means of moving traffic between freeways, expressways and crossroads. As a general rule, public road, commercial / private road and private access connections are not to be located within the functional interchange area, unless the location meets the City's offset spacing criteria as identified in Exhibit 1-5. Access connections are not permitted within a right-turn channelization, auxiliary lane, taper or similar facility at an interchange.

The Functional Interchange Area is the section of crossing road that extends both upstream and downstream from the physical freeway or expressway ramp terminal area itself. The area is controlled to enable a motorist to enter and pass through the ramp terminal intersection before having to consider a potential conflict at a subsequent access connection.

Practice – Access Connection Offset Spacing Criteria

Adequate spacing and access design for crossroads in the vicinity of interchanges avoids traffic backups onto the mainline and preserves safe and efficient traffic operation. Recommended access spacing adjacent to an interchange is indicated in Table 1-4 and Exhibit 1-5.

Table 1-4: Minimum Spacing for Highway Interchange with Two-Lane Crossing Road

	<i>Offset Spacing Criteria</i>	
	<i>W or X</i>	<i>Y or Z</i>
Intersecting Access	800 m (Desirable)	125 - 185 m
	400 m (Minimum)	

Source: after MTO (2007).

Note:

W or X Desirable/minimum offset spacing distance to first Public Road or signalized Commercial/Private Road access. No all-movement access connections may be placed between a ramp terminal intersection and the first Public Road or signalized Commercial/Private Road intersection. X is measured from the end of the corner radius of the terminal to the centreline of the first public or private roadway. W is measured from the end of a high speed ramp terminal to the centreline of the first public or private roadway.

Y or Z Desirable offset spacing criteria to first non-signalized Commercial/Private Road access and/or other access connection type; right-in/right-out only.

<i>Posted Speed</i>	<i>Desirable Offset Spacing Criteria</i>
50 km/h	125 m
60 km/h	150 m
70 km/h	160 m
80 km/h	185 m

Exhibit 1-5: Minimum Spacing for a Parclo A-4 Interchange

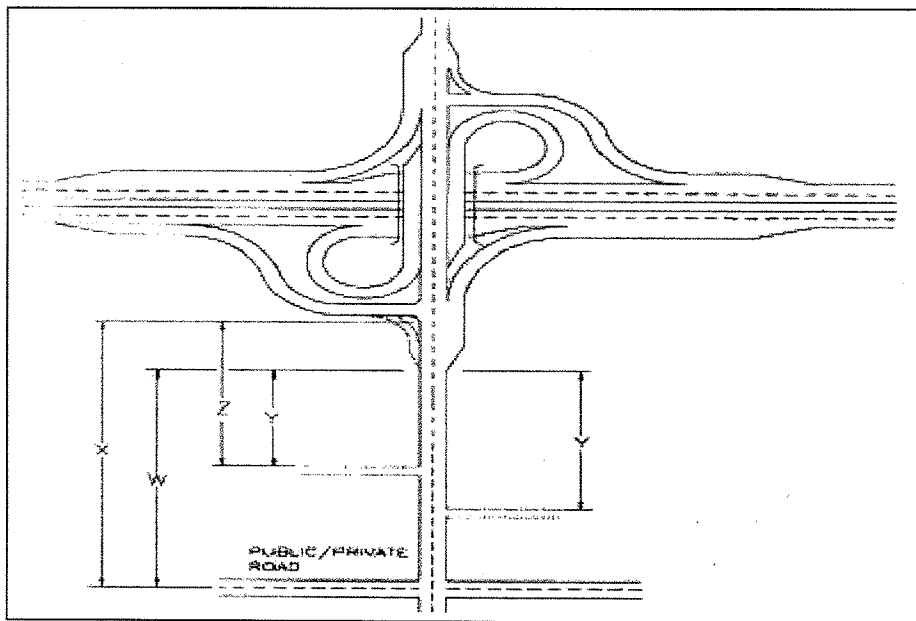

Source: MTO (2007).

Reference

MTO Highway Access Management Guideline, Final Draft, July 2007

1.6. Capacity and Level-of-Service

Any access connection to the arterial road system must offer sufficient capacity for all movements permitted. Left turn movements from the arterial road network must provide sufficient reserve capacity (v/c ratio <0.90) and a good level-of-service (level-of-service D or better). Left turns movement onto the arterial road network must have sufficient capacity ($v/c < 1.00$) and manageable delays and queues. Signalized access points must allow for adequate capacity ($v/c < 0.90$), and favourable road environment conditions. Where an acceptable level-of-service can not be maintained during peak hour conditions, and/or if there is potential to create unacceptable adverse operational and safety impacts on the arterial road network, directional prohibitions, rights-in and right-out, or right-in, or right-out may be implemented and/or required. Other mitigating measures such as roadway or traffic control improvements, joint access and/or common internal drive may also be necessary to facilitate access to the arterial road network.

Reference: Regional Municipality of Halton, Access Management Policy for Regional Roads

1.7. Alignment of Opposing Accesses

The introduction of a new driveway impacts directly on the existing traffic operations to and from the arterial road. Careful integration of a new driveway into the existing operating character of the arterial road is required to minimize turning conflicts and disruption to through traffic, subject to Section 1.4.2.

Practice

A centreline of a new driveway to the arterial road should align with the centreline of any opposing existing driveway or road. In some circumstances, an offset to the right may also be allowable. Exhibit 1-6 illustrates the driveway alignment.

Exhibit 1-6: Centreline Alignment

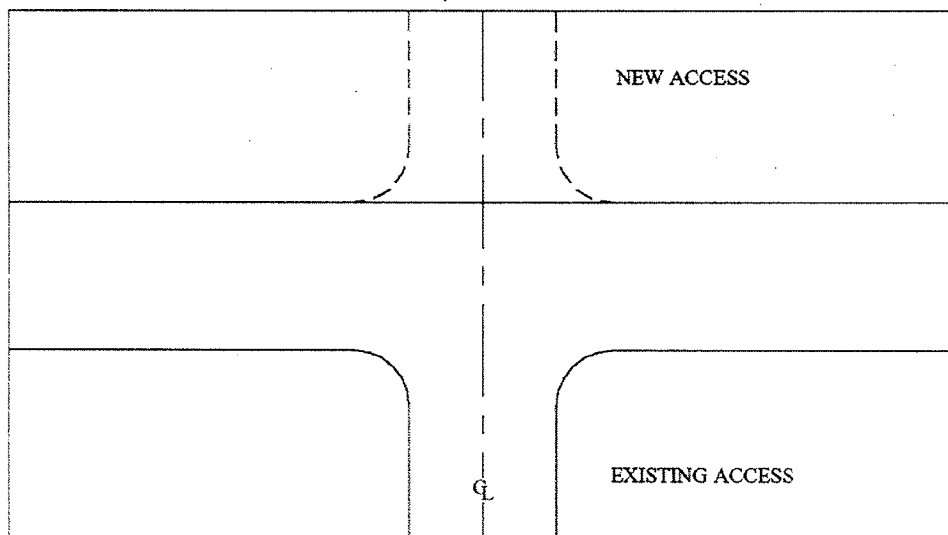

1.8. Angle of Access Centreline

The angle of intersection is the degree at which a driveway or road intersects with the arterial road as measured between the centreline of the new driveway and the centreline of the arterial road. It is desirable that the centreline of the new driveway and the centreline of the arterial road meet at or nearly at right angles to ensure safe sight visibility when manoeuvring to and from the site.

Practice

The angle of intersection at which a new driveway intersects with the arterial road should be 90 degrees as illustrated in Exhibit 1-7. The angle of intersection must not be less than 70 degrees or greater than 110 degrees. The exception is access arrangements for vehicle service stations that are permitted one-way operation driveways with 45 degrees to 60 degrees angles due to the unique operating nature of this type of facility.

References: MTO Geometric Design Guidelines for Ontario Highways, Metro Toronto Transportation Access Management Guidelines

Exhibit 1-7: Angle of Intersection

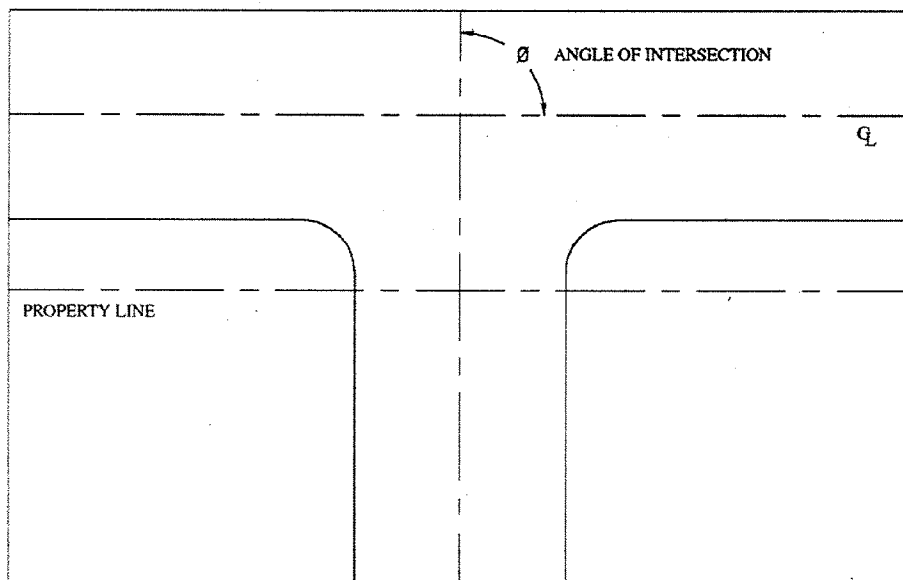

1.9. Site Inter-Connection

Service station sites are unique in that they rely significantly on pass-by traffic and are thereby permitted unique access arrangements of two or more access points located in close proximity to unsignalized/signalized intersections. For these reasons, activities between these sites and adjacent lands must be controlled. Site inter-connection can be positive if it promotes synergy between adjacent land uses, and properly removes traffic from the adjacent road network. Conversely, site inter-connection can be negative if it promotes “shortcutting”, and results in an increased volume of traffic entering an arterial road through an access located in close proximity to an intersection. Vehicular inter-connection between service station sites and adjacent lands must be justified.

1.10. Joint Access / Common Internal Driveways

Any property fronting onto a public street is entitled to an access drive except where there is a 0.3 metre (1 foot) reserve; access is permitted on another street where joint access has been established through a consent / severance. Joint access and common internal driveways reduce the number of direct access points to the arterial road, and minimize the opportunity for turning conflicts to occur on the municipal road network. They are used to connect both minor and major developments and to improve driveway spacing, which allows intensive development of a corridor, while maintaining efficient traffic operations, and safe and

convenient access to business. This type of access can also be beneficial in providing flexibility to meet local municipal objectives relating to such things as parking, loading facilities and landscaping, with a 0.3 metre (1 foot) reserve registered on title to prevent additional property access. Where minimum access spacing requirements cannot be achieved for a particular property adjacent to an arterial roadway, access shall be consolidated or a joint access and/or common internal drive system shall be established or planned, provided that the adjacent land use(s) is complementary in nature.

Proposed minor developments with arterial road frontage adjacent to complementary land uses are encouraged to implement a system of joint access and/or a common internal driveway to facilitate traffic flow between sites.

Proposed major developments adjacent to an arterial road frontage are encouraged (and may be required) to implement a system of common internal drives to provide access to adjacent complementary land uses. The site design shall incorporate the following:

- The site plan design should clearly depict all works associated to implement the joint access;
- If a common internal drive is required, the plans should show all works necessary to build the drive to the property line and including a temporary barrier to be removed when the common internal drive is constructed on the adjoining property;
- A continuous service drive or common internal drive corridor extending the entire length of each block served, to provide for driveway separation consistent with this Access Guideline; A design width sufficient to accommodate two-way travel, accommodating private automobiles, service vehicles, loading vehicles and emergency vehicles;
- The design must have consideration for adequate traffic control and traffic operation, provide adequate clear throat distance between cross drive isles and the arterial road to accommodate access and egress to / from the site, and must have consideration for pedestrian connections between sites; and

Pursuant to this section of the Access Guideline, affected property owners shall:

- Construct joint access in such way to allow adjacent property owner(s) to use the access for ingress and egress to and from their property;
- Record an agreement that remaining access rights along the subject corridor will be dedicated to the City of London and pre-existing driveways will be closed and eliminated following construction of the joint access and common internal driveways; and

Practice

The use of mutually-shared driveway arrangements is strongly encouraged. Their use is ideal when there is more than one business development at a given location, or a series of adjacent developments proposed over time. This type of driveway must be registered on title of both properties in order to protect the interests of both property owners in the event that either of the properties is sold. Exhibit 1.8 illustrates Joint Access driveway arrangement with a 0.3 meter reserve registered across the front of the property to prevent additional access to the property.

Exhibit 1-8: Joint Access

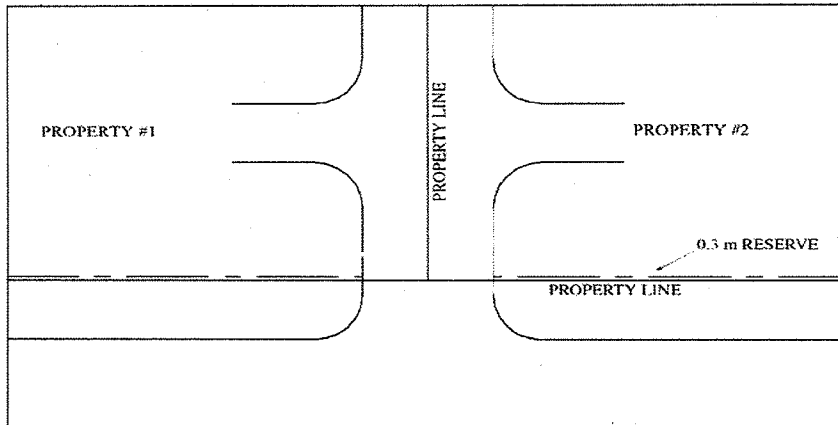

Reference: York Region Access Guideline for Regional Roads

1.11. Grade

Access to/from above-grade or below-grade parking facilities is provided by ramps. An at-grade landing is required between the ramp to the parking facility and the arterial road to ensure that adequate visibility is maintained for both pedestrian and vehicular activities.

Practice

An at-grade landing, with a maximum gradient of one (1%) percent for high volume driveways and three (3%) percent for low to moderate volume driveways must be provided for a minimum distance of 3.0 metres from the right-of-way limit (property line) to ensure safe sight lines for vehicular and pedestrian traffic. A maximum grade of four (4%) percent for high volume driveways and eight (8%) percent for low-moderate volume driveways will be permitted for any further ramping within 3.0 to 6.0 metres of the right-of-way limit. Plan and profile views of an at-grade landing are illustrated in Exhibit 1-9 and Exhibit 1-10 respectively.

Exhibit 1-9: Plan View of an At-Grade Landing

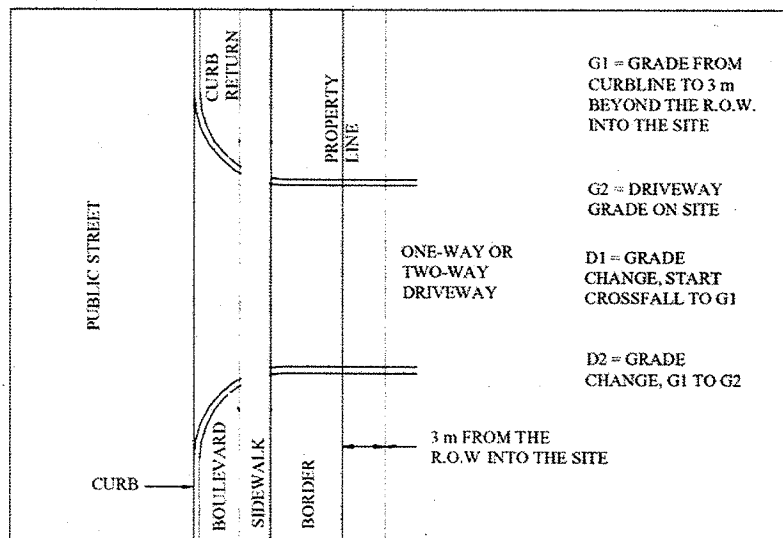

Exhibit 1-10: Profile View of an At-Grade Landing

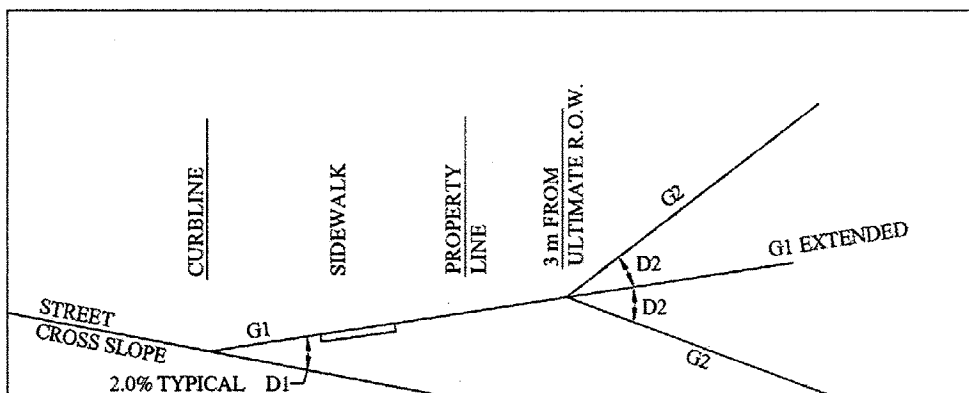

Exhibit 1-10 shows the acceptable driveway grades and grade changes.

Table 1-5: Driveway Grades and Grade Changes

Driveway Volume ⁴	Grade, G_1 ^{2,3}		Grade, G_2 , Maximum	Maximum Grade Change, D_1	Maximum Grade Change, D_2
	Min ¹	Max ²			
High	1.0%	1.0%	+4.0%	+3.0%	±3.0%
			-2.0%		
Low-Moderate	1.0%	3.0%	+8.0%	+5.0%	±5.0%
			-4.0%		

Notes:

1. 0.5% acceptable as absolute minimum.
2. Downgrades avoided to control street drainage.
3. Assumes the street has a normal cross slope of 2.0%.
4. High: >1500 vehicles/day; Moderate: >750 to 1500 vehicles/day; Low: 25 to 750 vehicles/day.

References: Part 2 of the TAC Geometric Design Guide for Canadian Roads (1999), Figure 3.2.9.5.

1.12. Sight Line Distance

As determined from Figure E3-8 of the MTO Geometric Design Standards for Ontario Highways, the following sight distances shall be provided at intersections and accesses:

- a) On new street intersections and major accesses such as large commercial or industrial development, the desirable decision sight distance shall be provided;
- b) On all other new accesses, the minimum decision sight distance shall be provided;
- c) For existing accesses and single family residences, the minimum stopping sight distance shall be provided.

This figure assumes a line of sight from the driver of a vehicle entering the intersection (1.05 metres above the pavement surface) to the headlights of an approaching vehicle (at height 0.38 metres). Note also that section 4.24 of City of London By-Law Z-1 may require a further setback from the right-of-way of structures and landscaping over 1 metre in height.

1.13. Access Widths

The lack of adequate driveway size can significantly influence safe and efficient traffic operation to/from the road; therefore it is important to provide adequate driveway width (W) and radii (R). Factors that must be considered include: the proposed land use, the type of operation (1-way or 2-way traffic flow), the volume of traffic, and the type of vehicles the driveway will serve. For example, if the driveway is to serve as a fire route, then the Ontario Building Code shall apply. Plans must be adequately dimensioned to simplify review process.

Width

Driveway width (W) should be restrictive enough to discourage erratic manoeuvres, control the location and angle of conflict points, and limit entry/exit to the intended number of lanes of operation. Whether a driveway will operate with one-way or two-way traffic flow must also be considered.

One-Way Driveway

A one-way driveway operates with a single entry or exit lane, as illustrated in Exhibit 1-11.

Practice

The minimum width of a one-way driveway measured at the throat ranges from 3.0 metres to 5.0 metres depending on the land use of the development, as outlined in Table 1-6.

Two-Way Driveway

A two-way driveway operates with at least one entry and one exit lane through a single driveway point, as illustrated in Exhibit 1-11.

Practice

The minimum width of a two-way driveway, measured at the throat, ranges from 6.0 metres to 9.0 metres depending on the land use of the development, as outlined in Table 1-6.

Exhibit 1-11: Driveway Layouts

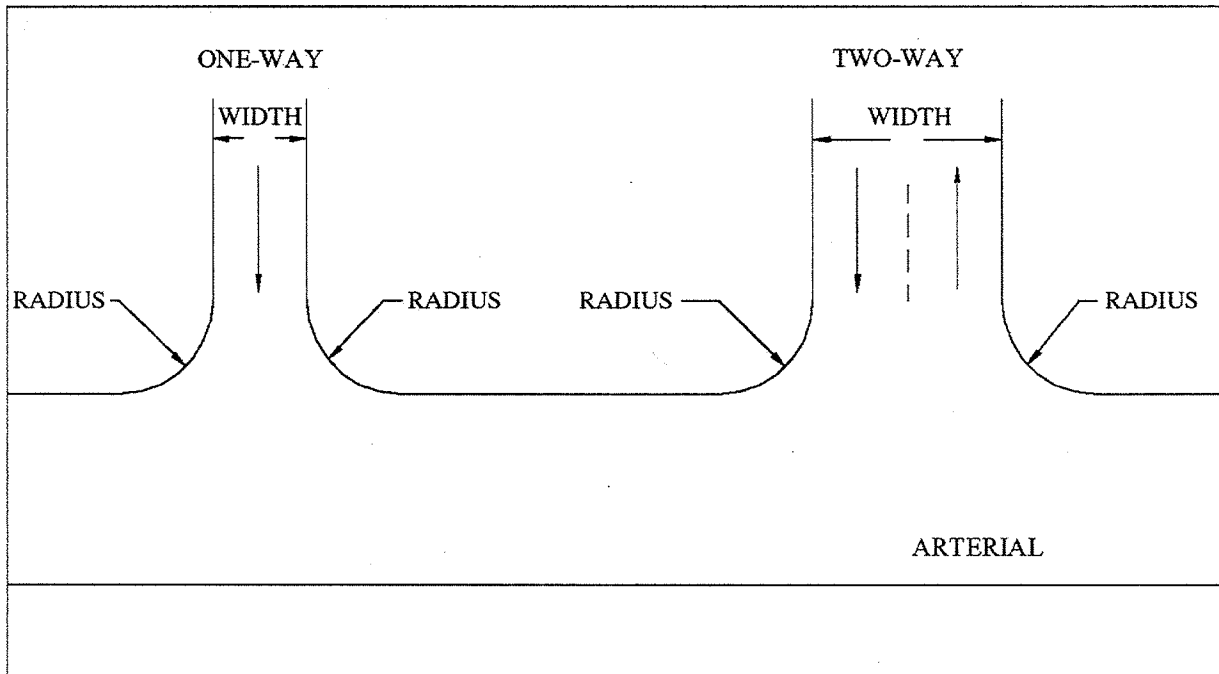

Table 1-6: Driveway Dimensions

Land Use	One-way Width (in metres)		Two-way Width (in metres)		Radius ³ (in metres)	
	Min ¹	Max ²	Min ¹	Max ²	Min ¹	Max ²
Residential (medium, high density blocks)	3.0	4.3	6.0	7.3	6.0	9.0
Commercial	4.5	7.5	6.7	12.0	9.0	12.0
Industrial	5.0	9.0	9.0	15.0	9.0	15.0

Notes:

1. Minimum driveway widths are normally used with radii at or near the upper end of the range.
2. Maximum driveway widths may be considered where more than one traffic lane (per direction) is required.
3. TAC turning templates should be used. The WB-19 (~69ft) vehicle turning template is the minimum for truck accommodation. Appendix A shows a TAC turning template for a WB-19 truck.
4. For residential single family, refer to City of London standard SR-2.0

References: Part 2 of the TAC Geometric Design Guide for Canadian Roads (1999), Table 3.2.9.1

1.14. Radii

The radius of the curb is related to the turning path of a vehicle making a right turn to or from the site, and the width of the driveway. The radius of the curb return or amount of flare/taper of the curb connecting the edge of throat of a driveway with the edge of the nearest travelled lane is an important element in ensuring that the driveway is accessible to all vehicular traffic.

Practice

The minimum curb radius ranges from 3.0 metres to 9.0 metres, depending on the type of land use being served by the driveway, as outlined in Table 1-6. The appropriate radius that permits the turning path of the vehicle to enter/exit the site without encroaching on the curb or the adjacent traffic lane is illustrated in Exhibit 1-12.

Exhibit 1-12: Radii

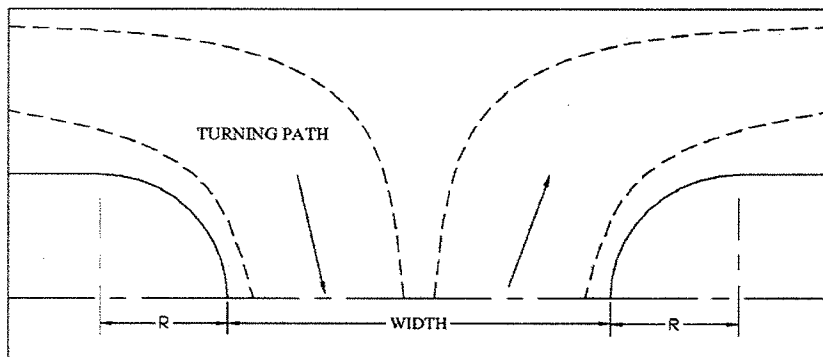

1.15. Curb Radius – No Encroachment

The introduction of a new driveway on a site should be developed entirely within the confines of the subject property so as not to negatively impact on development potential of adjacent sites.

Practice

The curb radius should not encroach on the frontage of the adjacent property. Therefore, the end of the radius should not extend past the projected property line of the site to the street line as illustrated in Exhibit 1-13.

Exhibit 1-13 Curb Radius – No Encroachment

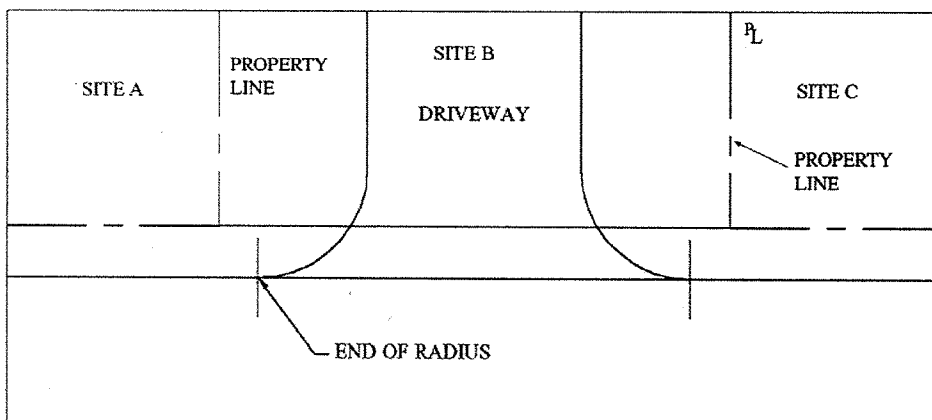

1.16. Curb Return Design

The curb return design provides distinct concrete curbing to facilitate the turning path of the vehicles turning to/from the driveway, without encroaching on adjacent travelled lanes, (if designed properly). This design requires a curb cut and sidewalk ramps to accommodate pedestrians.

Practice

A curb return design must be provided at a driveway if traffic volumes are more than 750 vehicles per day and/or significant truck traffic is present, or it's in an urban area. Dimensions for the driveway width and radii are discussed in Table 1-6. Exhibit 1-14 illustrates the curb return design.

Exhibit 1-14: Curb Return Design

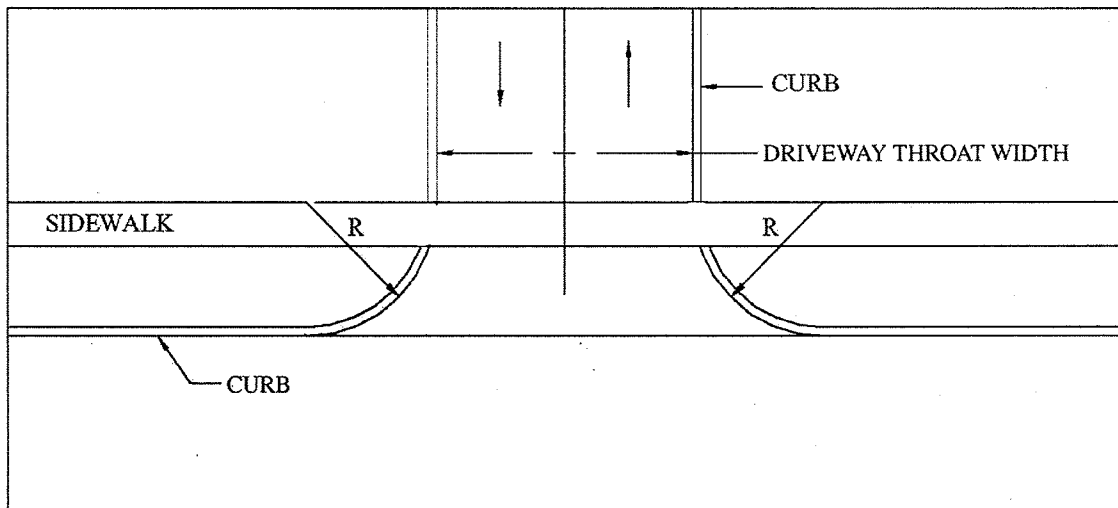

Refer to City Of London Standard Contract Document for Municipal Construction Projects, Section B – Part 1 - Roads.

2. ACCESS TURNING RESTRICTIONS

2.1. Operating Requirements

Turning movements must be controlled when safe and efficient traffic operations cannot be maintained between the arterial road or Primary Collector road and the proposed driveway. There are two methods of controlling turning activities: (a) turn prohibitions and (b) turn restrictions.

Turn prohibitions are controlled with the enactment of by-laws accompanied by appropriate signage.

Turn restrictions are additionally controlled by geometric improvements to physically prohibit the specific turning movement(s).

The enforcement of by-laws is difficult and, therefore, physical barriers are often required to provide an effective means of ensuring compliance with turning controls. The installation of concrete islands/medians physically prevents the specific turning movement(s) and directs vehicles into the defined turning paths. At some access points, full movements may be allowed in the short term, however the City may require that the owner accept that turning movements may be restricted in the future due to increased traffic volumes and/or safety concerns. The installation of Rights-In Rights-out islands ("Pork Chop") is proven to be ineffective for restricting left turning movements to and from access point and not typically supported by the City. However, in some locations it is very difficult and/or impossible to implement on street raised concrete median and Rights-in Rights-out island may be considered (Must be approved by Transportation Planning and Design Division).

Practice

Specific turning movements to/from a driveway will be controlled if the turning movements cannot be executed safely and efficiently with minimal disruption to traffic operations on the arterial or primary collector road.

The criteria used to determine when turning control restrictions will be required are as follows:

- An inbound left turn level-of-service (LOS) E or worse and v/c ratio \Rightarrow 0.9 during peak periods.
- An outbound left turn level-of-service (LOS) E or worse and a v/c ratio \Rightarrow 0.9 during peak periods.
- Adequate spacing between driveways is not provided (refer to Section 1.4 of this manual) to ensure that left turn conflicts are minimal.
- Minimum safe sight distances must be maintained in order to execute the anticipated turning movements while minimizing interference with existing traffic operations on the arterial road.

References

TAC Geometric Design Guide for Canadian Roads, Section 3.2.9 of Part 2.
ITE Transportation and Land Development, Chapter 5: Principles of Access Design, page 22.

2.2. Inbound Left-Turn Restriction

Exhibit 2-1: Inbound Left Turn Restriction to Driveways

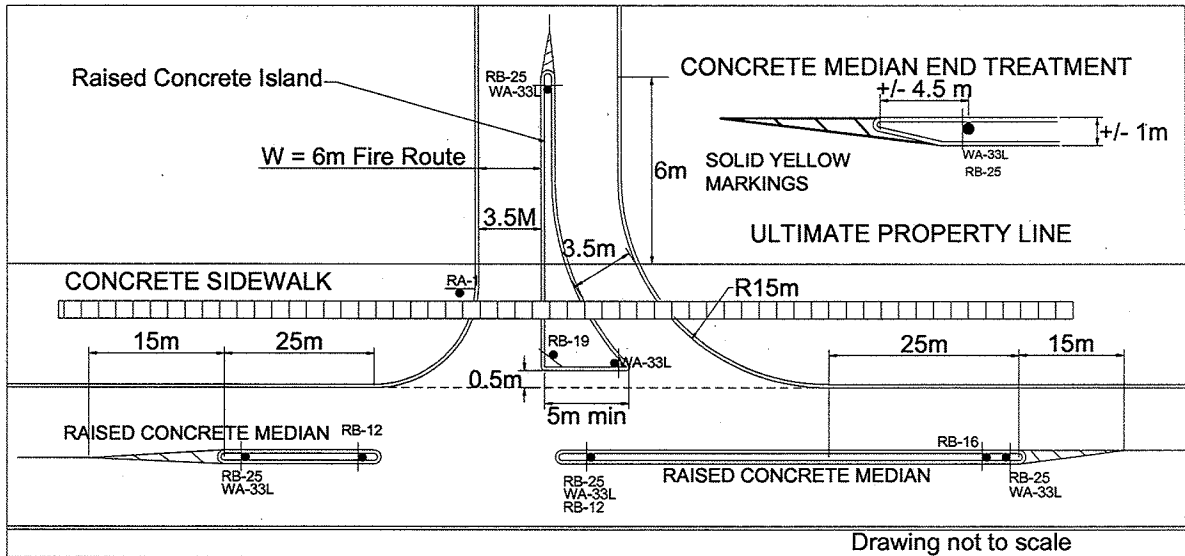

2.3. Left-Turn Egress Restriction

Exhibit 2-2: Left Turn Egress Restriction from Driveway

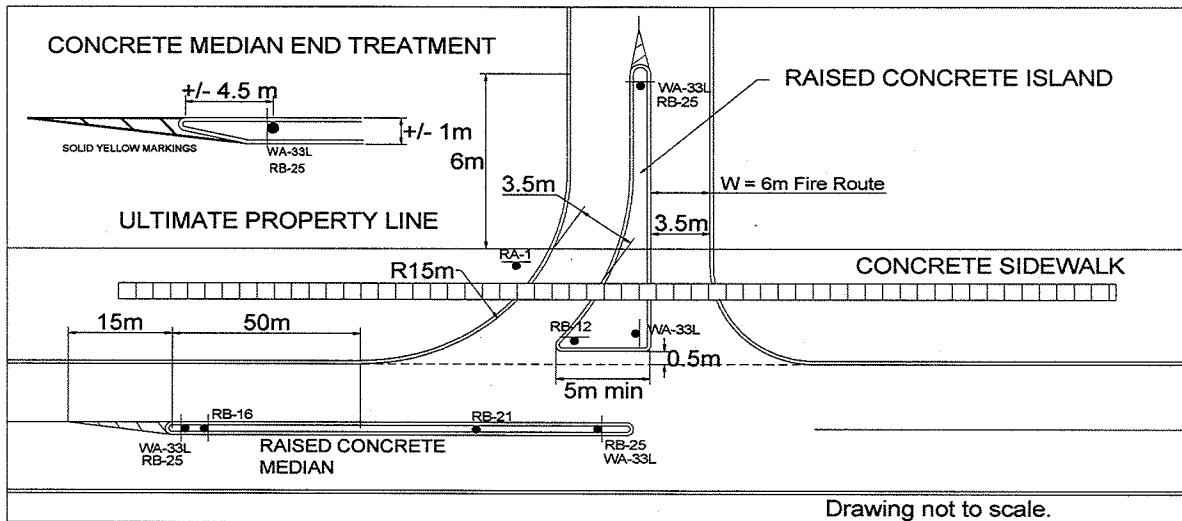

2.4. Rights-In / Rights-Out

Exhibit 2-3: Both Left Turns Restricted

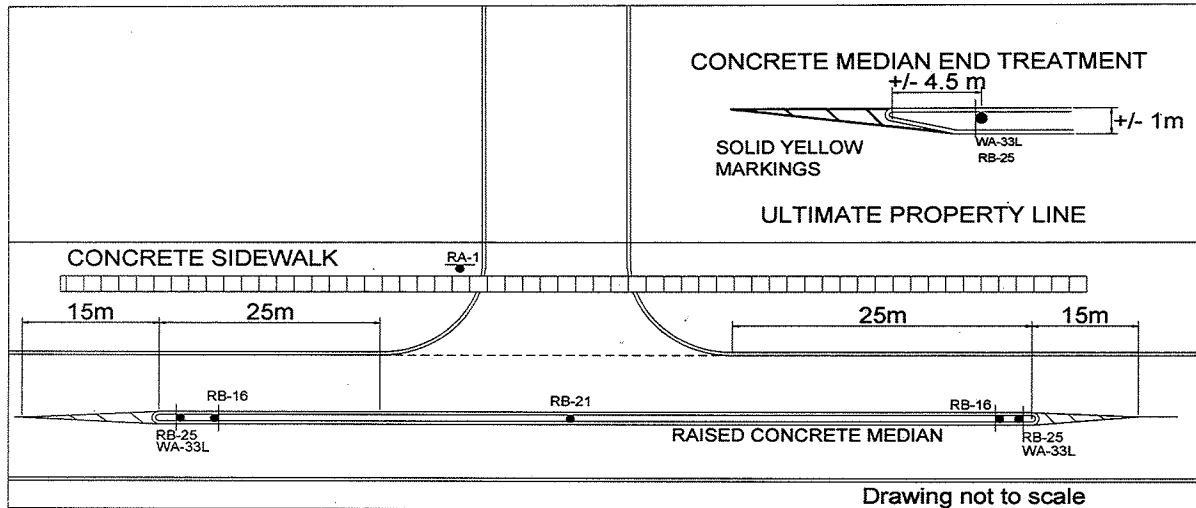

Rights-In / Rights-Out "Pork Chop"

Exhibit 2-4: Both Left Turns Restricted

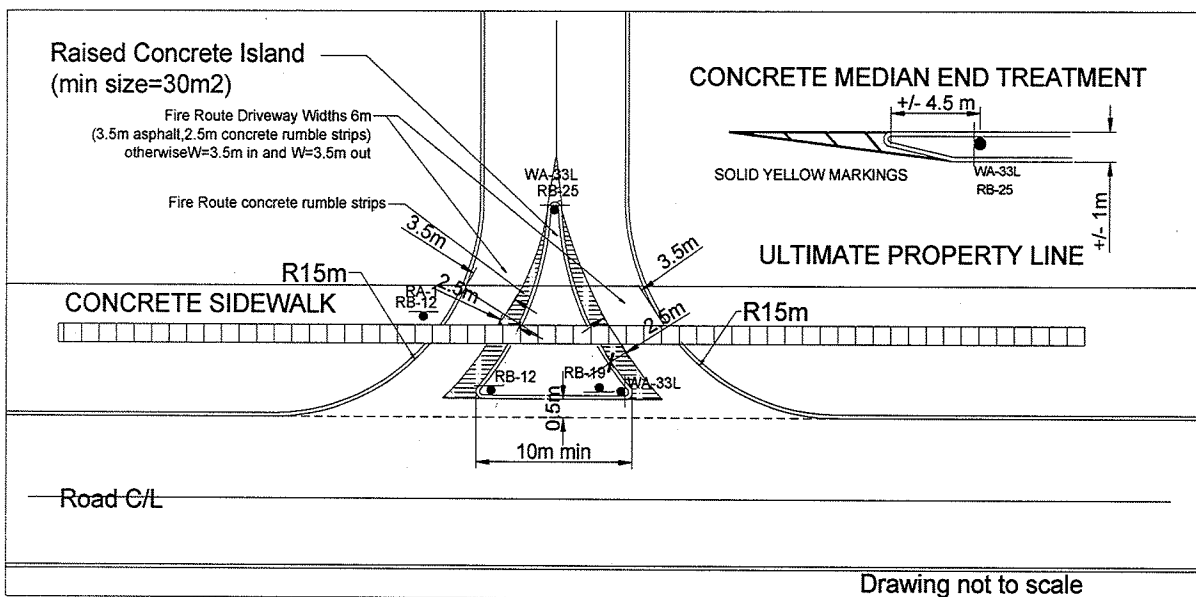

The use of trees and/or landscape materials in center medians and in some cases rights-in rights-out islands is encouraged when possible and to be reviewed and potentially approved by the City during Site Plan Approval Process.

3. ROADWAY FEATURES

3.1. Left Turn Lane

The left turn lane requirements for two-lane, four-lane, and six-lane divided and undivided roadways shall be based on volume warrants and collision warrants as identified by an accepted traffic impact study.

3.1.1 Volume Warrant

Practice

When opposing traffic volumes are such that left turning vehicles must wait for a gap to make their turn, they interfere with the through traffic. The magnitude of this interference depends on the opposing volume, the advancing volume and the percentage of left turning vehicles.

When traffic signals are warranted, storage lengths are subject to signal cycle timing. Volume warrants for left turns are based upon capacity calculations for intersections.

References

Part 2 of the TAC Geometric Design Guide for Canadian Roads (1999), Page 2.3.8.1

3.1.2 Collision Warrant

Practice

A left turn storage lane may be considered at locations where four or more collisions related to left turns occur per year or where six or more occur within a period of two years, provided the collisions are of a type which could reasonably be expected to be eliminated by provision of a left turn lane. The minimum storage length for the collision warrant is 15 m.

References

Part 2 of the TAC Geometric Design Guide for Canadian Roads (1999), Page 2.3.8.1

3.2. Right-Turn Lane

Practice

Although right turns are generally made more efficiently than left turn movements, exclusive right turn lanes are often provided, for many of the same reasons that left turn lanes are provided. Right turns may face a conflicting pedestrian flow, but do not face a conflicting vehicular flow. In general, an exclusive right turn lane should be considered when the volume of right turning vehicles is between 10 to 20 percent of the through volume, subject to a minimum of 60 vehicles per hour in the design hour. Design speed should be considered when determining right-turn requirements.

TAC recommends the use of an exclusive right turn lane when the volume of decelerating or accelerating vehicles compared with the through traffic volume causes undue hazard.

References

Highway Capacity Manual, Special Report 209, Third Edition (1998) by Transportation Research Board, National Research Council, Washington, Page 9-97.

3.3. Medians

Practice

A median may be defined as that portion of a road that physically separates the travel lanes of traffic in opposing directions. Median width is the lateral dimension measured between the inner (left) edges of the travel lanes and includes the left shoulder, the gutter or offset widths.

A median is a safety device that provides some measure of freedom from conflicting vehicular movements. The major uses of a median separation are to eliminate the risk of head-on collisions, and to reduce the risk of right angle collisions by controlling access.

A centre median is more effective than “pork chop” islands (See Exhibit 2-33) in enforcing right-in, right-out only access operations. While there are multiple causes that lead to the consideration of a median, it should be noted that ultimately, the primary intent of installing a median is improved safety. The installation of a centre median should be considered if:

- There is a history of right angle collisions in the vicinity of existing or proposed accesses;
- The left-out Level of Service is E or worse;
- If the queues on the adjacent roadway during one or more of the peak periods typically extend past the proposed location of the access;
- There is a series of closely spaced accesses;
- There is insufficient right-of-way to implement a two-way centre left turn lane, or, there is an existing two-way centre left turn lane, but with a history of right angle collisions;

If a centre median is installed, the traffic will be diverted to other routes. One potential outcome is that vehicles will complete U-turns at each end of the centre median. Therefore, the potential impact of these diversions should be weighed against the costs and benefits of installing the centre median.

While considering a centre median, thought should also be given to the effect of that median on adjacent or opposite properties.

Median widths may be as narrow as 1.0 metres as per Ontario Provincial Standard Drawing (OPSD). There must be 25 meters of upstream and downstream median length, measured from the back edge of radii (Refer to Figures 2.1., 2.2., 2.3., 2.4.) or as determined otherwise.

3.4. Signal Warrant

Signalization of a private access is normally considered in the context of a traffic impact report of a major development. Traffic signals shall be considered warranted if intersection conditions meet or exceed the warrant requirements of the Ontario Traffic Manual Book 12 as determined by a traffic survey. Minimum signal spacing requirements as identified under Section 1.4 “Spacing Requirements of Major Driveways and Intersection Spacing.”

3.5. Bus Bays

Bus Bays for London Transit vehicles may be a required improvement to street-side bus stops along arterial roadways. City administration will inform the developer if an existing transit stop in proximity to a development must be re-designed as transit bus bay.

3.5.1 Structure

Bus bays shall be constructed with a 200mm thick finished concrete surface and a 200mm thick Granular 'A' base. If the sub-grade is a weak or clayey material then a 300mm thick sub-base shall be added.

3.5.2 Geometry

The geometry of a London Transit bus bay is as follows:

- 18 m length;
- 3 m width;
- 25 m tapers on either end;
- OPSD 600.01 Concrete Barrier Curb with Wide Gutter or OPSD 600.04 Concrete Barrier Curb with Standard Gutter, as per Ontario Provincial Standard Details

The barrier curb and gutter runs along the back of the bay (side closest to the sidewalk/boulevard) and must match into the curb and gutter along the street. Standard gutter, defined by OPSD, separates the bay pavement from the street pavement and also must match into the barrier curb and gutter at the extreme ends of the tapers.

3.6. Sidewalks

3.6.1 Location

Sidewalks are required on both sides of all collectors and arterial roads and where the road width is in excess of 8.0 metres, measured from edge of pavement to edge of pavement.

Sidewalks are required on both sides for the complete length of any road on which a school property fronts.

The developer may be required to install sidewalks on both sides of an entrance to a subdivision from a bounding arterial road.

Sidewalks are required on one side only of cul-de-sac, or streets serving 40 or more units.

Sidewalks are required on one side of abutting arterial and primary collector streets along the full frontage of the subdivision, or as otherwise specified by the City Engineer.

Sidewalk is to be located on the outside of a crescent, unless approved by the City Engineer Administration.

3.6.2 Geometry

All sidewalks should align and be offset a minimum 1.5 metres from the proposed street line unless otherwise approved by the City Engineering Administration.

The minimum width of sidewalk in a residential subdivision is 1.5 metres, 1.8 metres wide when adjacent to curb on major roadways and 2.4 metres wide at schools, bus stops and other high volume pedestrian areas.

The sidewalk thickness is normally 100mm thick except at commercial, multi-family and industrial driveways where the thickness is increased to 150mm, together with a granular base. The minimum strength is 30Mpa with 5% to 7% air entrainment and low slump. The minimum gradient of a sidewalk is 0.5% and the maximum is 8%. For more information, refer to the City of London Design Standards.

Sidewalk ramps are to be installed at all commercial and residential accesses for the physically impaired as per City of London Standard SR-1.2.

Concrete Sidewalk with standard grass boulevard: reference City of London Drawing Standard SR-1.0.

Concrete Sidewalk Abutting Curb & Gutter: reference City of London Drawing Standard SR-1.1.

3.7. Bicycle Paths

Historically the City has supported the creation of In Boulevard Bicycle Paths (IBBP's) which are exclusive bicycle pathways located within specified arterial road right-of-ways, typically between the sidewalk and the curb lane of the traveled portion of the road. The City of London Bicycle Master Plan advocates a departure from this practice of providing for IBBP's along arterial corridors.

The Bicycle Master Plan identifies which arterial and collector corridors will become travel routes for cycling commuters. The bicycle routes have two classes: primary commuter routes and secondary commuter routes.

The City of London Bicycle Design Guidelines has two distinct design standards for cycling routes. The On-Road bicycle commuter route is a separate pavement-marked lane. The Widened Curb Lane provides extra pavement width that is not pavement-marked but is indicated as a commuter route with signage. More information can be found in the Bicycle Master Plan and City of London Bicycle Design Guidelines.

4. PARKING OPERATIONS

4.1. *Clear Throat Distance*

Clear throat distance is the length required on the driveway to store vehicles waiting to circulate into the site, usually a parking area. Failure to provide an adequate clear throat distance can create congestion and operational concerns on the arterial road, as well as safety concerns for pedestrians attempting to cross the driveway. Other locations requiring clear throat distance are at drive-through restaurants, drive-through bank machines and convenience stores. Drive-through windows may require an internal stacking lane.

The amount of clear throat distance is directly related to the required capacity of the parking lot.

Practice

The minimum amount of clear throat distance, measured from the right-of-way limit (or ultimate right-of-way limit when road widening dedication is required) to the designated point where turns are permitted, ranges from 6.0 metres to 15.0 metres, depending on the number of parking spaces provided on the site, as outlined in Table 4-1. This applies to both inbound traffic as well as outbound traffic.

Table 4-1: Clear Throat Distances – Parking Facilities

<i>Facility Size</i>	<i>Desirable</i>	<i>Minimum</i>
Parking space \leq 50 spaces	8.0 m	6.0 m
Parking Aisle \geq 50 to \leq 199 spaces	15.0 m	8.0 m
Parking Aisle \geq 200 spaces	24.0 m	15.0 m
Signalized large shopping centre development access (shopping mall, big box centre, etc)*	80.0 m	60.0 m

*Subject to traffic volumes generated by the site.

References

Metro Toronto Transportation Access Management Guidelines
MTO Highway Access Management Guideline, Final Draft, July 2007
Transportation and Land Development, 2nd Edition, ITE

Exhibit 4-1 illustrates direct access to a parking space, and Exhibit 4-2 illustrates access to a parking aisle.

Exhibit 4-1: Minimum Distance to a Parking Space

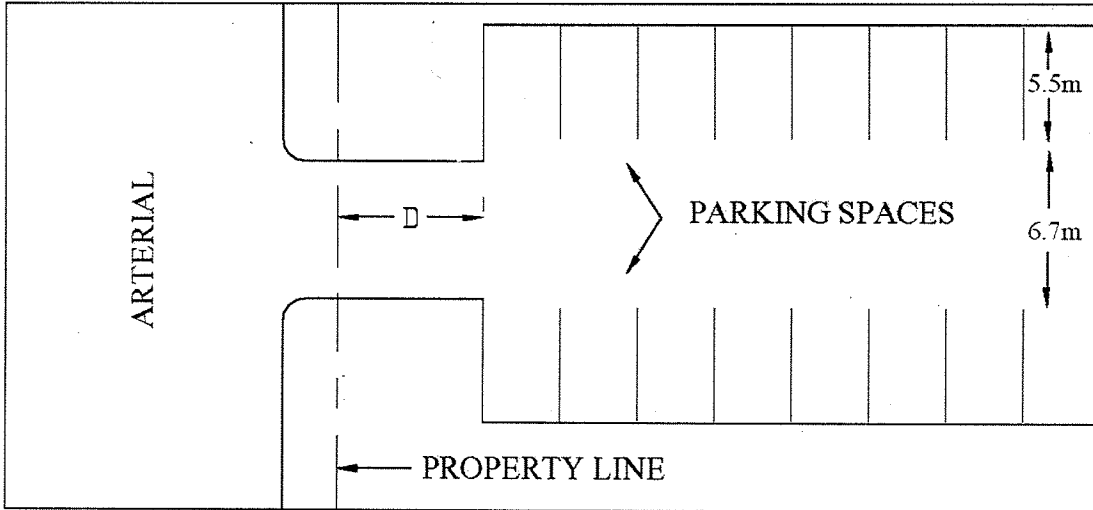
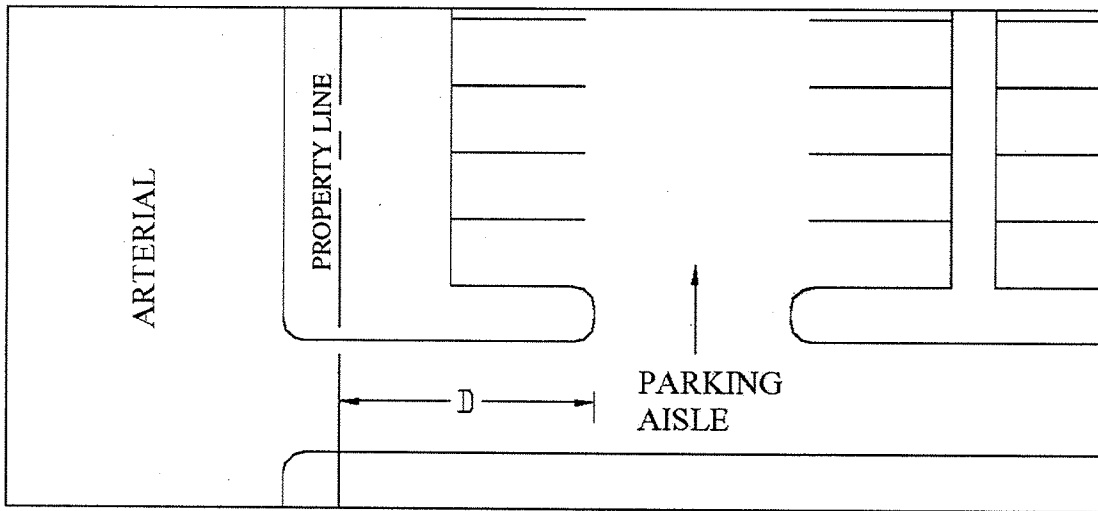

Exhibit 4-2: Minimum Distance to a Parking Aisle



4.2. Lay-Bys

A lay-by is used to facilitate high turnover demand for the pick-up and drop-off of people at facilities such as hotels, schools/daycare centres, hospitals, senior's residences, etc. The use of a lay-by ensures that a safe environment is provided for these activities, and that operations on the arterial road are not disrupted.

Practice

A lay-by will only be considered to facilitate the high turnover demand of person activities on sites that meet the following criteria:

- It must be demonstrated that the need for the lay-by facility is justified for its intended purpose, and that traffic operations on the arterial road will not be disrupted;
- Sufficient stacking space should be provided to accommodate the peak pick-up and drop-off demands. This should be demonstrated as part of the Traffic Impact Study;
- The operation of the lay-by must be restricted to one-way movements on the site. The turning movements permitted to and from the access points will be determined on a site-specific basis using the applicable site operations standards;
- The lay-by must be provided exclusively on private property; and
- Sufficient width must be provided for one vehicle to pass another.

Exhibit 4-3: Lay-by and Passenger Drop-off Zone

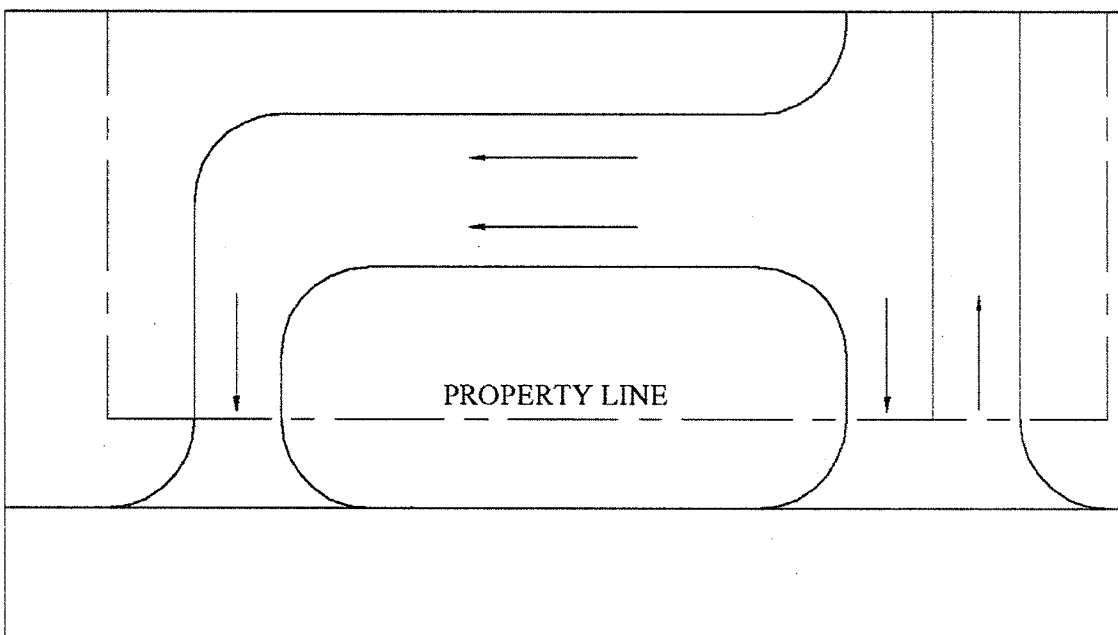

4.3. Turnaround Areas

A turnaround area is a designated area on a site, which is used when no parking spaces are available, to facilitate turning around so that vehicles exit the site in a forward motion.

Practice

A designated turnaround area must be provided on site so that vehicles may exit the site in a forward motion onto the arterial road. The minimum size of the turnaround area (for the purposes of a passenger car) is 4.2 metres by 6.0 metres. Transportation Association of Canada (TAC) templates must be used to ensure that an appropriate turning path is available to execute the turning manoeuvres.

Exhibit 4-4 illustrates minimum requirements for a passenger car.

Exhibit 4-4: Turnaround Area for Passenger Vehicle

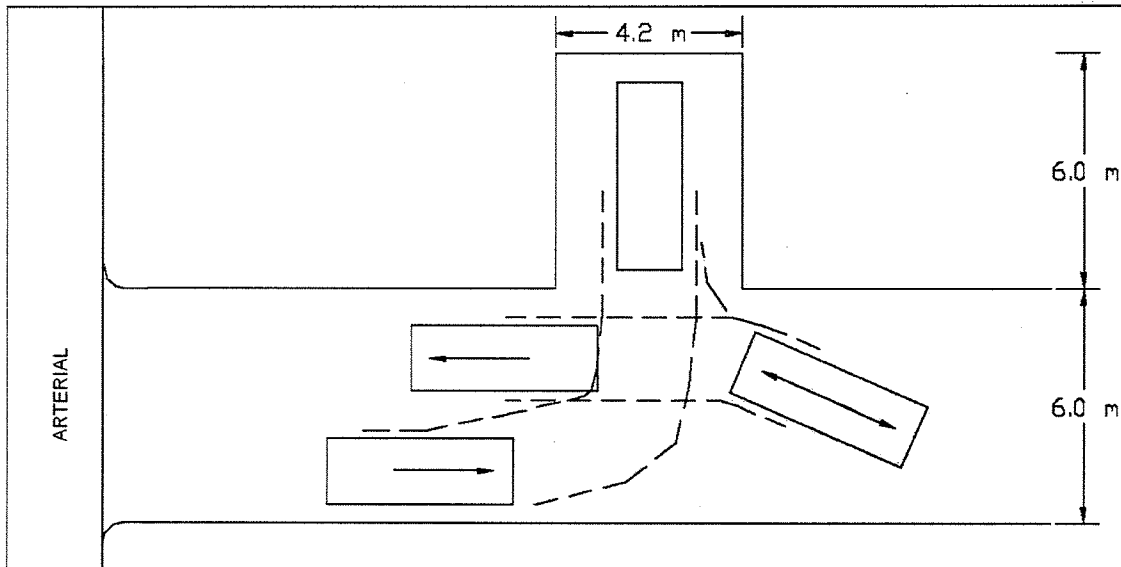

4.4. Drive-Throughs

Drive-through facilities are becoming more popular and are used predominately at banks and fast food restaurants. Parking and circulation activities on these sites must be accommodated simultaneously without creating internal conflicts that may result in congestion or queuing on the arterial road. The proponent is strongly encouraged to review the City of London Zoning By-Law Z-1 for compliance with zoning requirements.

4.5. Loading Docks

Loading and courier areas are used to facilitate the pick-up and drop-off of goods and services, and in most cases, are provided at separate locations. These activities must be provided on site to minimize disruptions to traffic operations on the arterial road.

Practice

Loading and courier facilities must be provided based on the following criteria:

- Exclusively on private property;
- Vehicles must be able to enter/exit the site in a forward motion;
- Must be located internally on the site so as not to interfere with traffic operations in the area of the site driveway;
- Use of these facilities must not interfere with the remaining site circulation.

- Number size and location of loading docks as set out in City of London Zoning By-laws.

An example of the provision of loading and courier facilities is illustrated in Exhibit 4-5.

Exhibit 4-5: Loading and Courier Areas

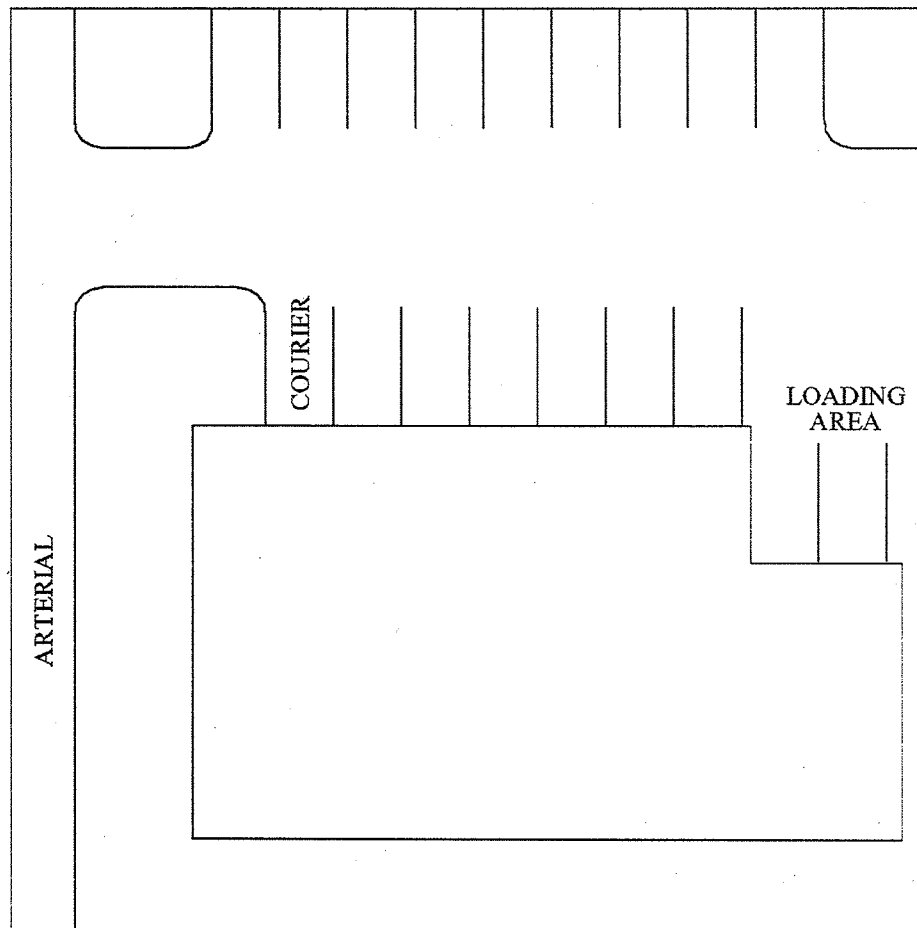

4.6. End Island Treatments

Parking lots are often designed to maximize the available parking space with no consideration given to the driver's line of sight. Stalls that are adjacent to travel lanes will block the line of sight of a driver in perpendicular lanes (refer to Appendix B). For this reason end-islands are typically employed.

APPENDIX A

TURNING TEMPLATE

TAC TURNING TEMPLATE FOR A WB-19 TRUCK

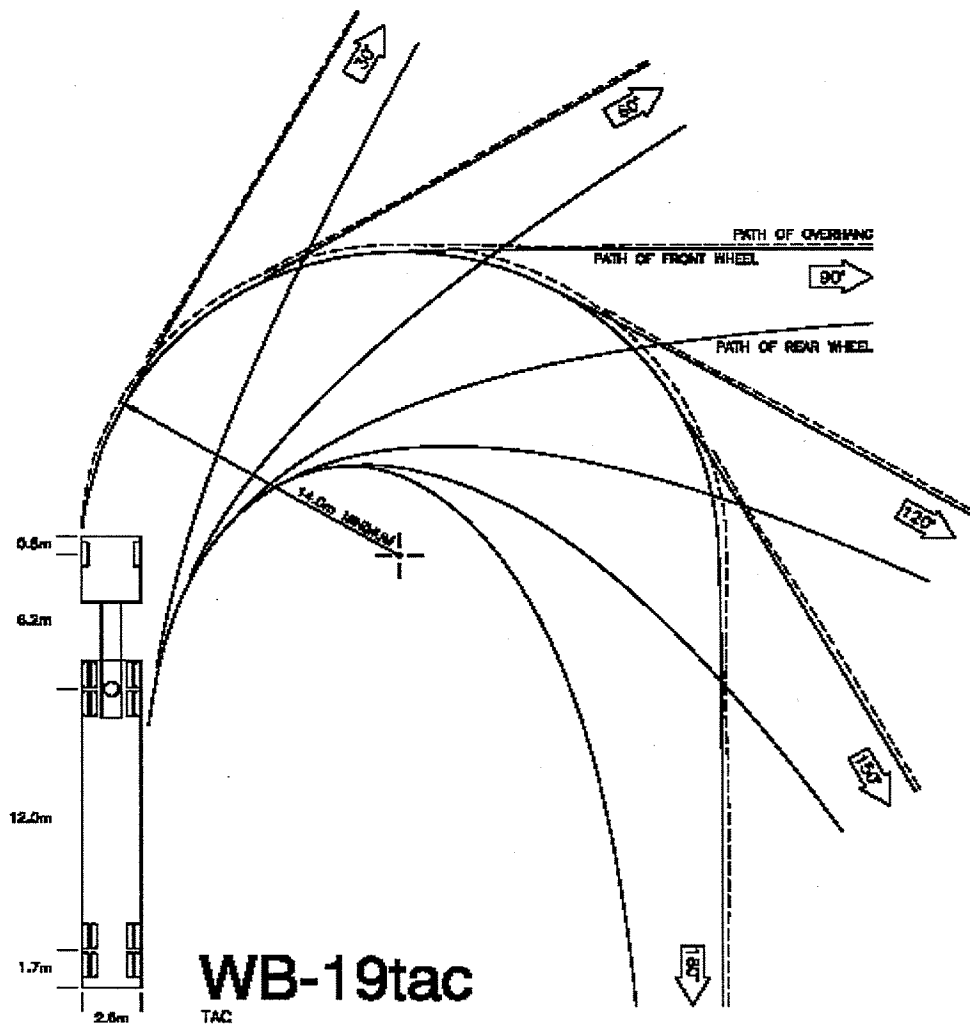

APPENDIX B

END ISLAND TREATMENTS ABUTTING INTERNAL DRIVES

DESIGN DIMENSIONS

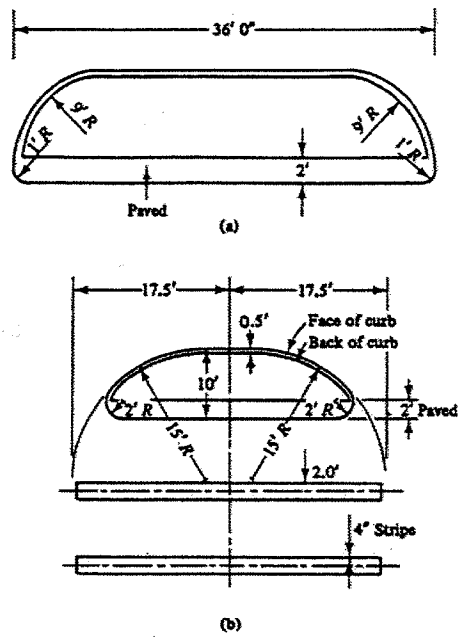

Figure 7-16 Typical end-island designs for ninety-degree parking.

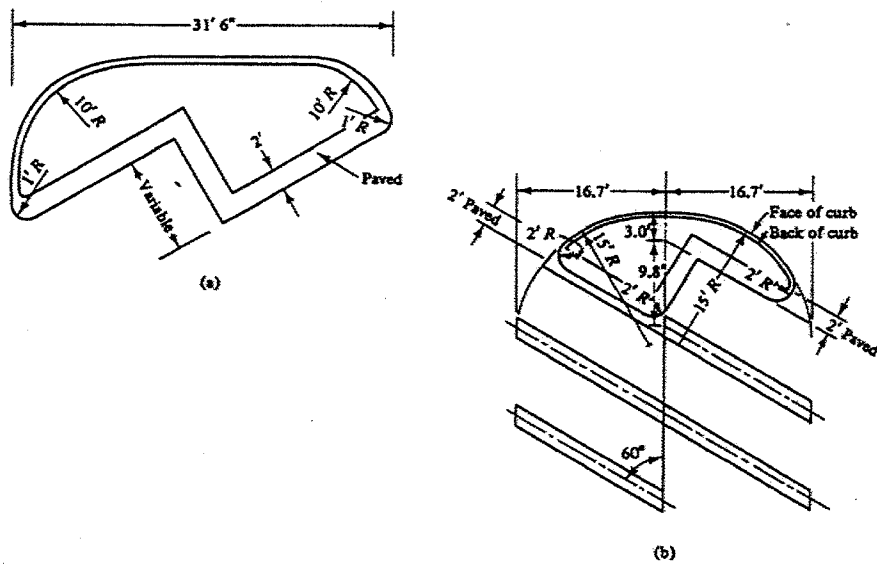
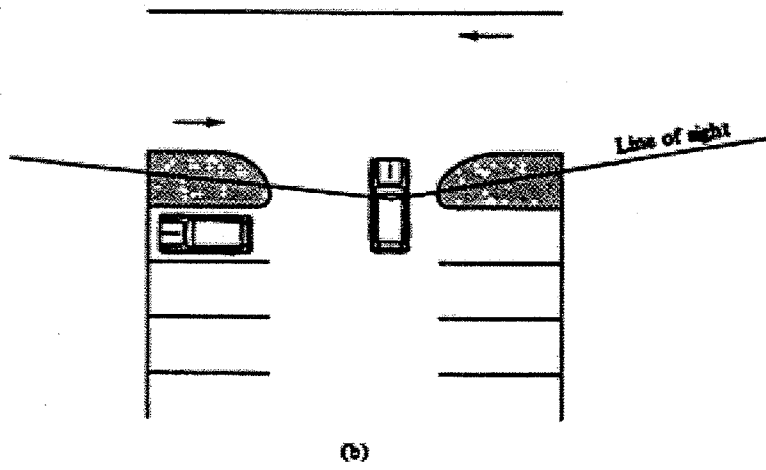
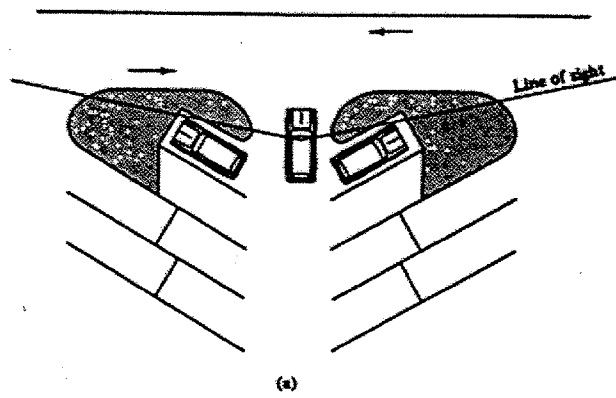

Figure 7-17 Typical end-island design for sixty-degree parking.

PREFERRED OPTION



NOT PREFERRED OPTION DUE TO ONE-WAY TRAFFIC OPERATIONS



Island sizes may vary to accommodate plantings, trees and/or planting, trees with concrete sidewalk.

Agenda Item # Page #

--	--

Appendix 'B'

Transportation Impact Assessment Guidelines



London
CANADA

City of London

TRANSPORTATION IMPACT ASSESSMENT GUIDELINES

MAY 2011

ACKNOWLEDGEMENTS

The Transportation Impact Assessment Guidelines were originally prepared by IBI Group in 2006. Since then, additional modifications have been incorporated by City staff. These guidelines are the summation of contributions made by both parties. The City of London gratefully acknowledges IBI Group for their assistance and technical input provided.

TABLE OF CONTENTS

1.	INTRODUCTION	1
1.1	Transportation Impact Assessment – General	1
1.2	Why is a Transportation Impact Assessment Required?	1
1.3	Applicability	1
1.4	Acknowledgement of Authorship/Ownership.....	3
2.	TIA REQUIREMENTS AND SCOPE.....	3
2.1	When is a Transportation Impact Assessment Required?.....	3
2.2	TIA Scope/Detail	4
2.3	Report Format.....	4
2.4	Other Jurisdictional Requirements.....	6
2.5	Functional Life of TIA.....	7
3.	DESCRIPTION OF THE DEVELOPMENT PROPOSAL AND THE ASSESSMENT AREA.....	7
3.1	Description of the Development or Redevelopment Proposal.....	7
3.2	Description of Study Area	8
	3.2.1 Definition of the Study Area	8
	3.2.2 Features of Study Area.....	8
4.	ANALYSIS PERIODS.....	10
4.1	Horizon Year(s).....	10
4.2	Analysis Periods	11
5.	EXISTING TRANSPORTATION CONDITIONS	11
5.1	Traffic Conditions.....	11
5.2	Transit Operations	12
6.	BACKGROUND TRAFFIC	12
6.1	Future Developments.....	12
6.2	Background Growth in Transit Demand/Planned Transit Service.....	13
7.	SITE TRAVEL DEMANDS	13

TABLE OF CONTENTS (CONT'D)

7.1	Estimation of Traffic Demand.....	13
7.2	Travel Demand Management (TDM) Strategies	14
7.3	Trip Distribution and Assignment.....	14
	7.3.1 Trip Distribution	14
	7.3.2 Trip Assignments	14
7.4	Summary of Traffic Demand Estimates.....	15
7.5	Site Generated Transit Demand (As Required).....	16
8.	EVALUATION OF IMPACTS OF SITE GENERATED TRAVEL DEMAND	16
8.1	Evaluation of Impacts of Site Generated Traffic Demand.....	16
8.2	Evaluation of Impacts of Site Generated Transit Demand.....	17
9.	TRANSPORTATION SYSTEM IMPROVEMENTS	18
9.1	Identification of Required Road Network Improvements.....	18
9.2	Identification of Required Transit System Improvements	19
9.3	Implementation and Funding of Required Improvements	20
10.	SITE PLAN, PARKING AND ACCESS REQUIREMENTS	20
11.	DOCUMENTATION AND REPORTING.....	21
LIST OF EXHIBITS		
	Exhibit 2-1 – General TIA Scope.....	4
	Exhibit 2-2 – Specific TIA Elements	5
	Exhibit 3-1 – Example Road Network and Traffic Control Graphic.....	10
	Exhibit 7-1 – Example Traffic Volume Graphic	15
	Exhibit 9-1 – Example Road Network Improvement Graphic	19
LIST OF APPENDICES		
	Appendix A – Certificate of Authorship/Ownership	
	Appendix B – Typical Assessment Process Flow Chart	

1. INTRODUCTION

1.1 Transportation Impact Assessments – General

A transportation impact assessment (TIA) provides valuable information and analysis for governing agencies and others reviewing development and redevelopment proposals. The City of London Transportation Impact Assessment Guidelines have been compiled to outline the process and structure required to produce a comprehensive transportation impact assessment for a development or redevelopment proposal in the City. A transportation impact assessment should include consideration of all modes of travel including automobiles, trucks, transit vehicles, cyclists and pedestrians.

1.2 Why is a Transportation Impact Assessment Required?

The main purpose of a TIA is to demonstrate that the transportation impacts of a proposed development or redevelopment will be manageable and that the transportation aspects of the proposal are consistent with the objectives and policies of the City of London. The TIA also provides the basis for the identification and evaluation of transportation related improvements or mitigation measures to be included as conditions of approval for the development or redevelopment application. Hereafter, all references to the terms development or development proposal will be equally applicable to redevelopment applications/proposals as well.

Through the TIA, the proponent must demonstrate that the application meets these criteria, as summarized below:

- That there is sufficient road network capacity to accommodate the proposed development, taking into account transportation system improvements and travel demand management initiatives which will be secured/identified in conjunction with the proposal;
- That the development be phased, if necessary, in conjunction with the implementation of transportation system and service improvements and travel demand management initiatives, to ensure that supply and demand are balanced over time;
- That the proposal incorporate a suitable travel demand management strategy which includes all reasonable measures to facilitate and promote transit, cycling, walking and ride-sharing for trips to and from the site;
- That the number of vehicular parking spaces provided in conjunction with the proposal be minimized with explicit consideration for short and long term parking demands, special needs parking and commercial vehicle loading facilities; and
- That the development must be successfully integrated with the London road and transit systems with respect to vehicular and pedestrian access and connections to the transit system. In some cases, provision may have to be made for on-site transit stations and related facilities and services.

1.3 Applicability

It should be recognized that the policies and standards included in this document are relevant at the time of printing. These guidelines will be revised, as necessary, to reflect current City policy, practice and accepted standards.

The Proponent shall contact City of London staff to identify any major modifications to this document since its compilation date.

The following document outlines general guidelines for the preparation of transportation impact assessments for submission in the City of London. There may be instances where the guidelines and general assessment assumptions may not be applicable to certain locations in the City, or specific types of developments. It should be recognized that the purpose of this document is to provide a framework for the preparation of a TIA and shall not be substituted for good transportation engineering judgement.

In addition, there may be cases where the scope of the TIA can be reduced due to previous approvals or studies in the area or on the site. **Sections 2.1 and 2.2** include a discussion regarding the scope of a transportation impact assessment at various points in the development approval process.

For additional information or for clarification of any of the material contained in this document, please contact the following departments/agencies, as applicable:

Transportation Planning and Traffic Operations Inquiries

Manager, Traffic Engineering
and Transportation Planning
City of London
300 Dufferin Avenue, 8th Floor
London Ontario
N6A 4L9
Telephone: 519-661-2500

**Subdivision/Site Plan Inquiries:
Development Approval Business Unit**

Manager, Development Planning
City of London
300 Dufferin Avenue, 6th Floor
London Ontario
N6A 4L9
Telephone: 519-930-3500

Transit Inquiries:

Director of Transportation and Planning
London Transit Commission
450 Highbury Avenue N
London, Ontario
N5W 5L2
Telephone: 519-451-1340

Planning/Development Inquiries:

Planning and Development
City of London
204-206 Dundas Street,
London Ontario
N6A 4L9
Telephone: 519-661-4980

Provincial Roads Contact:

Ministry of Transportation of Ontario
Regional Traffic Section, South-western Region
659 Exeter Road
London, Ontario, N6E 1L3
Telephone: 519-873-4351

1.4 Acknowledgement of Authorship/Ownership

When the scale of the development warrants a transportation assessment, it is the Proponent's responsibility to retain an experienced transportation consultant.

The City of London requires that a transportation impact assessment be prepared and/or reviewed by a qualified firm/individual. The individual taking responsibility for the Proponent's transportation impact work must be a registered Professional Engineer with more than five years of applicable experience in the preparation of transportation impact studies.

Included in **Appendix A** is a Certificate of Ownership that must be submitted with each TIA or addendum, including the stamp of the professional engineer taking responsibility for the work. In completing this form, the engineer is verifying that appropriate assumptions and methodologies have been used in the completion of the transportation impact assessment and is identifying who the individual(s) are taking corporate/professional responsibility for the work. This information will also assist city staff in contacting the appropriate individual if clarification of any part of the transportation impact assessment is required during the review process, or in the future.

2. TIA REQUIREMENTS AND SCOPE

2.1 When is a Transportation Impact Assessment Required?

There are a number of considerations in determining the need, elements and level of detail for a TIA. Generally a TIA may be required when one or more of the following are anticipated/present:

- The development proposal will add more than 100 peak-hour vehicle trips to the transportation system;
- The development is planned with an access to an arterial roadway within 200 metres of a signalized intersection;
- The development is located in an area of high roadway congestion, high operating speeds, and limited sight distance where safety is an issue;
- The development, its access, or type of operation, is not envisaged by existing land-use or transportation plans;
- The development requires a change or an exception to the Official Plan or zoning by-law, long range policy, strategy or plan, including rezoning;
- The development is a large recreation or entertainment facility that would likely serve as a regional attraction;
- The development has the potential to create unacceptable adverse operational and safety impacts on the area road network;
- The development will create transit/ridership demand that cannot be properly serviced by existing facilities, routes, frequency, hours of operation, etc; and/or
- The previous TIA prepared for the same site is outdated.

The above criteria are necessarily general and in view of the lack of definitive criteria to establish the need for and scope of a TIA for a particular proposal, the Proponent shall consult with City of London; Transportation Planning & Design staff, to determine site specific TIA requirements.

2.2 TIA Scope/Detail

The level of detail and the required components of the TIA will be a function of the location, size and operation of the development proposal. Included in **Exhibit 2-1** is a summary of the points in the development approval process where a TIA may be requested and the overall purpose of the TIA. **Appendix B** includes a general assessment flow chart for a complete TIA.

In some cases, the size, location and nature of the proposal will be such that a detailed transportation impact assessment is not required. Through discussions with City staff, the proponent may be required to prepare a transportation impact statement, which would outline the general characteristics of the site, its operation and trip generation/ridership potential, and a high level assessment of traffic impact, access, safety and parking requirements. The transportation impact statement would be a technical letter, stamped by a Professional Engineer specializing in transportation planning, which outlines the required components agreed upon with the City.

The proposed development may lie within an area for which a recent and relevant Area Plan has already been completed. Under this scenario, the City shall determine if certain elements of the TIA can be omitted or directly incorporated into the current TIA work, i.e., background growth potential, identified arterial road improvements, etc.

Exhibit 2-1 – General TIA Scope

Stage of Approval	General Transportation Impact Assessment Scope
Area Plan/Secondary Plan	<ul style="list-style-type: none"> • Identification of major/arterial transportation infrastructure and operational improvements associated with area wide development potential • Determination of the collector roadway network and the major intersection configurations and type of control
Draft Plan of Subdivision	<ul style="list-style-type: none"> • Arterial and collector roadway requirements and operations • Phasing plan • General description of access locations and operations • Allocation of responsibility for funding and implementation of transportation infrastructure improvements ¹
Rezoning	<ul style="list-style-type: none"> • Phasing plan • Transportation infrastructure improvements tied to phasing plan • Description of access locations and operations • Allocation of responsibility for funding and implementation of transportation infrastructure improvements ¹
Site Plan	<ul style="list-style-type: none"> • Access location and operations • Transportation infrastructure improvements tied to phasing plan • Site specific impacts on road network including adjacent site operations
<p>Note: (1) May consist of urban works funds, city services funds, city capital/operations budgets, and/or site-specific proponent costs.</p>	

Included in **Exhibit 2-2** is an indication of the components that the City of London will require at the various points in the development process. The proponent is to review the TIA requirements included in the column representing their specific point in the development process and discuss relevancy with City of London Staff.

The onus will be on the Proponent to demonstrate that certain aspects of the general requirements for a TIA are not required based on the point in the approval process, or availability and content of recent studies. The proponent should discuss the assessment scope and confirm it with the City before initiating it.

Exhibit 2-2 – Specific TIA Elements

TIA Component	Site Development Process			
	Secondary Plan/Area Plan	Draft Plan of Subdivision	Rezoning	Site Planning
Transportation Network				
Major transportation improvements <ul style="list-style-type: none"> • Planned roadways • New interchange/intersection including roundabouts • Road widening • New transit routes/services • Pedestrian and bicycle routes 	√	√	√	√
Local transportation system improvements <ul style="list-style-type: none"> • Intersection improvements • Traffic signal installation or modifications • Traffic calming plans 		√	√	√
Long range transit route and facilities planning (> 5 years)	√	√		
Short term transit service planning		√		√
Travel Demand Analysis				
Development potential beyond the study area	√	√	√	√
Project specific travel demands and assignments		√	√	√
Site specific travel demand from other approved developments within study area			√	√
Area wide transit demands	√	√		
Required transit service levels			√	√
TDM measures	√	√		√
Transportation Analysis				
Arterial road link capacity, intersection location, configuration and control	√	√	√	√

TIA Component	Site Development Process			
	Secondary Plan/Area Plan	Draft Plan of Subdivision	Rezoning	Site Planning
Traffic control, lane requirements and operations at collector and local road intersections	√	√	√	√
Storage lengths and tapers for auxiliary lanes at all intersections		√	√	√
Transit route planning	√	√		
Transit stop locations and operations		√		√
Bicycle route planning	√	√		
Off-site pedestrian facilities		√		√
On-street parking requirements/provisions		√	√	√
Driveway access and operations			√	√
Traffic infiltration potential	√	√	√	√
Traffic management plan including traffic calming elements	√	√		
Site Operations				
Driveway access design and operations including sight distances and corner clearances			√	√
On-site transit facility design				√
On-site pedestrian/bicycle facilities and operations				√
Weaving/merging issues			√	√
On-site traffic calming elements				√
Parking and loading layout and design				√
Parking supply			√	√
Improvements and Funding				
Identification of major transportation infrastructure improvements	√	√	√	√
Allocation of responsibility for funding and implementation of major transportation infrastructure improvements	√	√	√	√
Funding of local physical and operations improvements	√	√	√	√
Site Phasing and Required Improvements		√		√

Having established the TIA scope, the remainder of this guideline document, including the appendices, outlines the acceptable methodologies with which to document the required components.

2.3 Other Jurisdictional Requirements

In addition to the requirements outlined herein for the City of London for the preparation and submission of a transportation impact assessment, the County of Middlesex and the Province of

Ontario may require additional information or analysis to satisfy their requirements for a development proposal.

The proponent shall meet with all affected jurisdictions simultaneously to expedite the process and ensure consistency for the TIA scope/approach.

The Proponent shall contact other City departments, and County and Provincial staff directly to determine these needs. Contact information for these agencies is available in **Section 1.3**.

2.4 Functional Life of TIA

Generally, a transportation impact assessment will have a "functional life" of three years. However, major planning/ development, road network or transit changes within the study area during this timeframe may reduce the applicability of the document if they were not previously considered.

3. DESCRIPTION OF THE DEVELOPMENT PROPOSAL AND THE STUDY AREA

A description of the development proposal, the proponent, its location and the proposed TIA study area is required to allow City Staff to identify the site location, its anticipated operation and area of potential impact. In addition, this valuable information allows timely review of key assessment assumptions. Provided below is a summary of the required elements of the project and study area.

3.1 Description of the Development or Redevelopment Proposal

The following components of the project shall be summarized at the beginning of the transportation impact assessment document, *as applicable*:

- Existing land uses or "as-of-right" provisions in the Official Plan, zoning by-law etc.;
- Planned staging of the development;
- Boundary roadways, near-by intersections and accesses to adjacent land uses or developments;
- Proposed access points and types;
- Nearby transit facilities; and
- Pedestrian linkages.

For site specific TIAs the following shall be provided, as applicable:

- Municipal address;
- Rezoning application number;
- Total building size, building locations and number of units;

- Floor space including a summary of each type of use;
- Number of parking spaces along with location and access arrangements;
- Number and type of loading areas along with location and access arrangements; and
- Anticipated date of occupancy and hours of operation, if known.

As applicable, the Proponent shall provide area road network, subdivision drawings or a preliminary site plan, of a suitable scale, for consideration in the evaluation of the transportation impact assessment.

3.2 Description of Study Area

3.2.1 DEFINITION OF THE STUDY AREA

Generally, the size of the study area will be a function of the size and nature of the development proposal and the existing and future operations of the surrounding road network.

The study area shall encompass all City, County and Provincial roads, intersections, interchange ramp terminals and transit facilities, which will be noticeably affected by the travel generated by the proposed development. Typically, this will include area that may be impacted by one or more of the following:

- Increase by 5% or more of traffic volumes or transit usage on adjacent facilities;
- Volume/capacity (V/C) ratios for overall intersection operations, through movements, shared through/turning movements increased to 0.9 or above;
- V/C ratios for exclusive movements increased to 0.9 or above.

Since the definition of a TIA study area cannot be based on definitive criteria, it is important that the Proponent contact City Transportation Staff to establish mutually acceptable study area limits and scope of assessment.

3.2.2 FEATURES OF ASSESMENT AREA

A description and an illustration of the existing transportation system within the study area shall be provided in the existing conditions section of the TIA and shall include, but not be limited to, the following:

- Roads indicating the number of lanes, jurisdiction and posted speed;
- Signalized/unsignalized intersections and interchange ramp terminals indicating, as relevant:
 - Lane configurations, widths and storage lengths;
 - Available permitted movements;

- Type and mode of control/detection;
 - Turning restrictions, by time of day/day of week, as applicable; and
 - Transit facility locations specifically bus stops, bays and lanes.
- Location of sidewalks, bicycle paths/routes and pedestrian control such as crossovers, intersection pedestrian signals (IPS) and school crossing guard locations;
 - Location of on-street parking, parking/stopping restrictions adjacent to the development, which would affect the operation of the roadways and intersections in the study area;
 - Transit facilities and routes, which serve or will be expected to serve the development site; and
 - Truck routes/heavy vehicle restrictions including the times they are in effect;
 - Planned roadway, transit and pedestrian improvements which will have a noticeable impact on the transportation operations within the study area; and
 - Other developments in the study area, which are under construction, approved or for which an application has been submitted. Briefly describe the size (i.e., units, GFA, etc.) and nature of these developments in general terms.

Included in **Exhibit 3-1** is an example of a typical graphic that should be included with the description of the study area.

Exhibit 3-1 – Example Road Network and Traffic Control Graphic

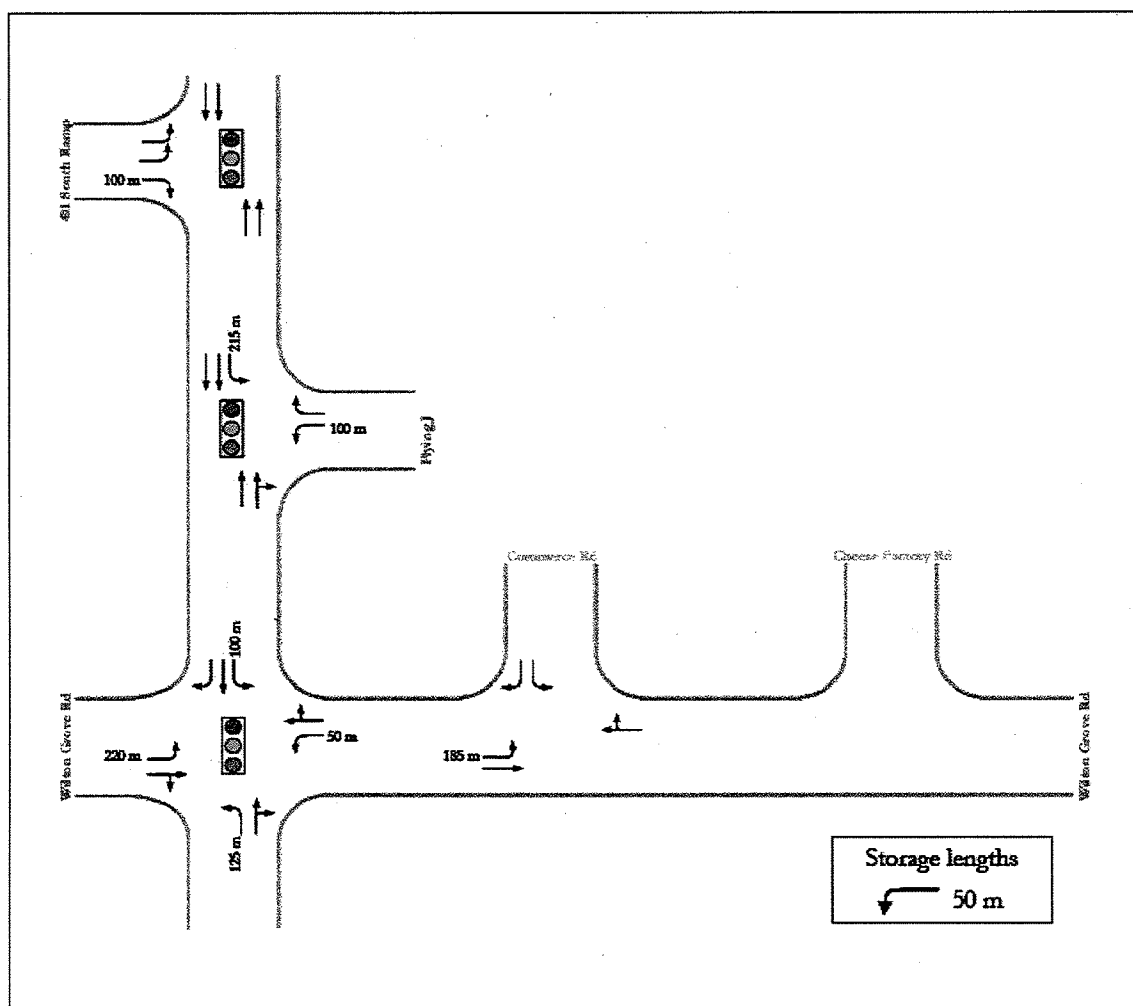

4. ANALYSIS PERIODS

4.1 Horizon Year(s)

Generally, the horizon year will be taken as five (5) years from the build-out of the site/area. Other considerations to be taken into account are as follows:

- Area plan/secondary planning horizons;
- Other area development proposals;
- Future roadway infrastructure and transit initiatives; and
- Occupancy date.

Interim horizon years may need to be evaluated to account for:

- Phasing of developments;
- Interim site access arrangements; and/or
- Planned transportation system improvements.

It is important that the Proponent obtain agreement from City Staff regarding appropriate horizon years for the specific development prior to proceeding.

4.2 Analysis Periods

Identification of the time periods for analysis should take into consideration the following:

- Type and size of development;
- Trip generation potential during weekday AM and PM peaks of the adjacent road network;
- Hours of operation;
- Reoccurring special events; and
- Seasonal fluctuations.

Typically, the weekday AM and PM peak traffic periods will constitute the "worst case" combination of site related and background traffic; however, in the case of commercial, entertainment, religious, institutional, sports facility uses, weekend or site peak analysis may be required.

5. EXISTING TRANSPORTATION CONDITIONS

5.1 Traffic Conditions

To provide a representative picture of the existing traffic conditions, the following shall be included in the TIA, as applicable:

- Exhibit(s) showing the existing traffic volumes for the roadways and intersections in the study area including pedestrian volumes and heavy vehicle percentages. Traffic volumes may be acquired from the City, previous transportation planning, traffic operation or transportation impact studies undertaken in the vicinity of the proposed development. In general, traffic counts more than three (3) years old or counts that do not appear to reflect current conditions, shall be updated by the applicant;
- Intersection analysis of the existing conditions for all peak periods. The analysis shall be undertaken with the methodologies outlined in the City's standards for intersection operations (Refer to Section 02 of the City's Design Specifications and Requirements http://www.london.ca/Cityhall/EnvServices/Water/design_specs.htm). Calibration of the analysis to actual conditions must be undertaken;
- Summary of the performance measures including level-of-service (LOS), volume to capacity (v/c) ratios and queue lengths (95th percentile queue) for all intersections and

accesses individual movements. Full documentation of the results of all level of service analyses shall be provided in an appendix;

- A summary of key collision or safety issues identified through consultation with City Transportation Staff; and
- Summary of key field observations of the existing conditions.

5.2 Transit Operations

To provide a representative picture of the existing and planned transit conditions within the study area, the following shall be included in the TIA, as applicable:

- Commentary/exhibit(s) summarizing to the existing transit routes, stops and facility locations;
- Approximate walking distance and dedicated route to the transit services from the proposed development;
- Transit vehicle headways/frequency for routes that service or may be anticipated to service the development proposal.

Transit information and current planning is available from the London Transit Commission.

6. BACKGROUND TRAFFIC

6.1 Future Developments

The Proponent shall include anticipated traffic growth on the area road network from developments that are expected to proceed prior to or within the selected assessment horizons (as identified in **Section 4.1**). This may include land zoned for development, but for which there isn't an active development application.

The Proponent shall contact the City's Planning Department and Development Approval Business Unit to establish the approved/active development proposals within the Study Area and the City's Transportation Department to confirm the predicted traffic growth from these development proposals

The background changes in traffic growth shall take into account:

- Area-wide development potential;
- Developments that are being constructed;
- Occupancy levels of adjacent development, i.e., buildings which are constructed but not fully occupied; and
- Developments/land uses that are planned to be closed, or activities suspended which will noticeably impact the transportation system in the study area.

6.2 Background Growth in Transit Demand/Planned Transit Service

An assessment of anticipated transit ridership and service changes resulting from development and London Transit Commission initiatives must be incorporated into the analysis.

The background growth in transit demand must recognize:

- The transit travel and TDM initiatives of the City of London;
- Reasonable transit modal split assumptions; and
- Developments that are currently being constructed, not fully occupied or approved and are anticipated to be constructed prior to the proposed development.

The Proponent shall contact London Transit Commission Staff to determine major changes to transit services or demands in the vicinity of the development site.

7. SITE TRAVEL DEMANDS

7.1 Estimation of Traffic Demand

Available trip generation methods may include one or more of the following, and will be a function of the proposed development and its intended operations:

- Trip generation surveys from similar developments in the City of London or comparable municipality, which have similar operating characteristics as the proposed development;
- ITE Trip Generation rates provided that differences in the site operations and size are accounted for; and
- "First principles" calculations of anticipated trips to/from the site.

Where appropriate, it may be justified to reduce the base trip generation rates of the proposed development to account for:

- **Pass-by Trips** - Trips that represent intermediate stops on a trip already on the road network, i.e. a motorist stopping into a service station on their route to/from work. Pass-by trips must be accounted for in the turning movements into/out of the site;
- **Transit Usage** – Reductions in automobile travel to the site to account for travel to/from the site by public transit. Transportation planning projections/goals shall be considered; however, shall not replace good engineering judgement and actual modal split data.
- **Captive Market Effects** - Trips which are shared between two or more uses on the same site; and.

- **Travel Demand Management (TDM)** – strategies to be employed at the proposed development to reduce single occupancy vehicle (SOV) trip making, i.e., staggered work hours, ridesharing, company/hotel shuttle, etc (Refer to **Section 7.2**).

All trip generation assumptions and adjustments assumed in the calculation of "new" vehicle trips shall be supported and documented. Sensitivity analysis shall be undertaken where trip generation parameters have the potential to vary considerably and most probable values cannot be readily identified.

7.2 Travel Demand Management (TDM) Strategies

The City of London Transportation Master Plan (May 2004) has established a goal of reducing its SOV dependency by 10% below current forecasts over a 20 time horizon (2024). Accordingly, all TIA submissions shall include a suitable travel demand management plan which includes all reasonable measures to facilitate reduced automobile reliance and promote transit, cycling and walking for trips to and from the site.

The TDM section of the TIA shall provide:

- A description of the TDM initiatives and their function; and
- An evaluation of the impacts of the proposed TDM initiatives specifically relating to reduced trip generation associated with the site, reduced peak hour travel, reduced parking demands and increased transit usage/auto occupancy.

7.3 Trip Distribution and Assignment

7.3.1 TRIP DISTRIBUTION

The trip distribution assumptions should be supported by one or more of the following, in the order of preference:

- Origin-destination surveys;
- Comprehensive travel surveys;
- Employment and population data – a data file is available from City Staff along with a map;
- Existing/anticipated travel patterns; and/or
- Market studies.

Engineering judgement shall be used to determine the most applicable of the above methodologies for each particular application.

7.3.2 TRIP ASSIGNMENTS

Trip assignment assumptions shall reflect the most "probable" travel patterns considering the planned site access(es). Traffic assignments may be estimated using a transportation planning model or "hand assignment" based on knowledge of the proposed road network in the study area.

The assumptions shall take into account projected “pass by” trips, “diverted” trips, and “internal” trips.

7.4 Summary of Traffic Demand Estimates

A summary of the existing and future traffic demands shall be provided in a series of graphics that summarize the following:

- Existing traffic;
- Future background - existing plus background traffic growth;
- Site generated traffic including a separate graphic for pass-by trip assumptions; and
- Future total traffic - future background + site generated traffic.

An example exhibit is included in **Exhibit 7-1**. Summary exhibits must be provided for each peak period and analysis horizon. In some cases, interim traffic conditions may need to be assessed to reflect phasing of developments, interim site access arrangements or planned transportation system improvements.

Exhibit 7-1 – Example Traffic Volume Graphic

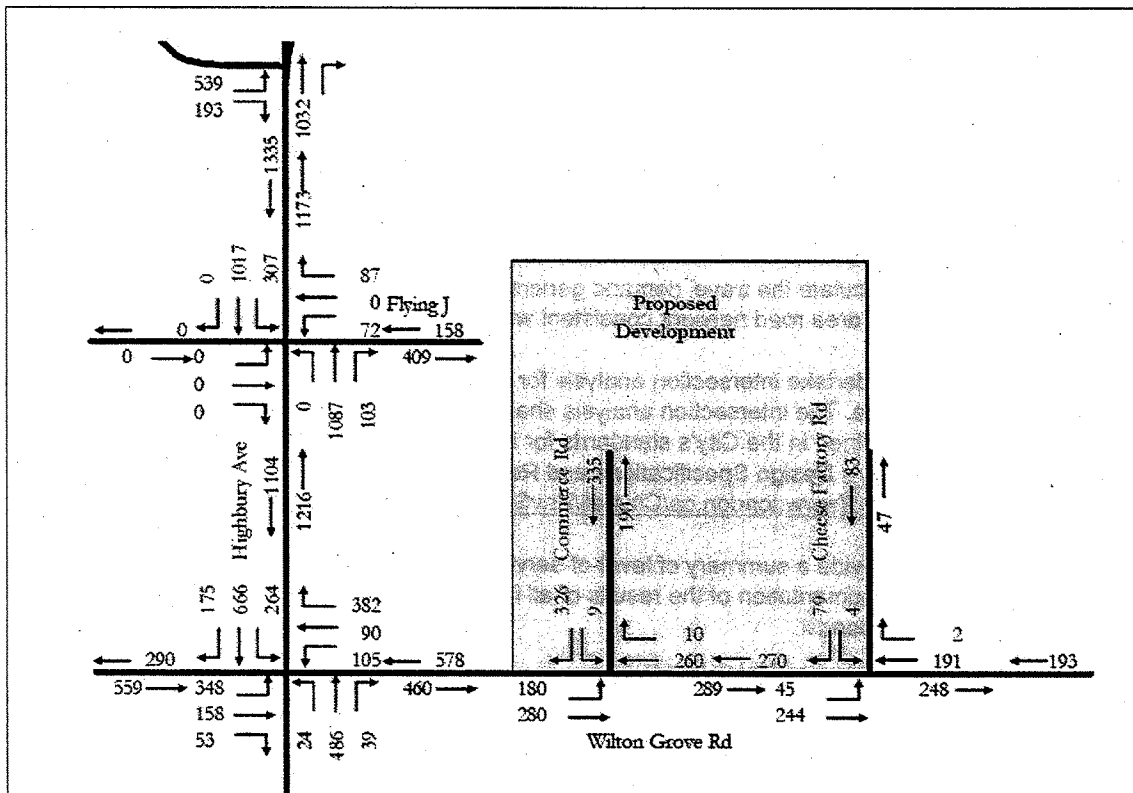

7.5 Site Generated Transit Demand (As Required)

The level of detail required by the City will be dependent on the nature of the development area and its reliance on transit usage. The site generated transit demand must reflect the assumptions outlined in the auto trip generation assumptions.

In order of preference, one or more of the following may be used to establish the transit demand for the proposed development:

- Transit surveys provided by the London Transit Commission;
- Transit surveys/data obtained from a similar development with proper adjustments for major differences between the proposed and surveyed site;
- "First principles" calculations of anticipated transit trips to/from the site; and/or
- ITE Trip Generation rates for transit.

The Proponent shall contact London Transit Commission Staff early in the impact review process to establish mutually acceptable assumptions for transit usage for the development proposal.

8. EVALUATION OF IMPACTS OF SITE GENERATED TRAVEL DEMAND

8.1 Evaluation of Impacts of Site Generated Traffic Demand

The following are the steps that shall be undertaken to evaluate the impacts of the site-generated traffic on the area road network:

- Calculate the travel demand generated by the development proposal and assign it to the area road network consistent with the methodology outlined in **Section 7**.
- Undertake intersection analysis for all intersections and accesses within the study area. The intersection analysis shall be conducted with the general assumptions outlined in the City's standards for intersection operations (Refer to Section 02 of the City's Design Specifications and Requirements http://www.london.ca/Cityhall/EnvServices/Water/design_specs.htm);
- Provide a summary of level-of-service for all analysis periods and time horizons. Full documentation of the results of all level of service analyses shall be provided in an appendix.
- Identify intersections and proposed accesses where:
 - Volume/capacity (V/C) ratios for overall operations, through movements, shared through/turning movements increased to 0.9 or above and Level of Service "E" or worse;
 - V/C ratios for dedicated turning movements increased to 0.9 or above and Level of Service "E" or worse;

- Queues for an individual movement and turning movement projected to exceed available lane storage (95th percentile queue).
- Identify potential safety or operational issues associated with the following:
 - Weaving/merging;
 - Corner clearances;
 - Sight distances;
 - Vehicle-pedestrian conflicts;
 - Access conflicts;
 - Traffic infiltration;
 - Cyclist operations;
 - Heavy truck movement conflicts;

All of the above considerations may not be applicable to the development site/area. It should also be recognized that the above list is not exhaustive and there may be other operational or safety concerns that may need to be addressed in the TIA; and

- Provide supplementary analysis required to address vehicle queue lengths/queue blocking, merging, weaving, gap availability/acceptance, sight distance availability, etc.

8.2 Evaluation of Impacts of Site Generated Transit Demand

The following are the steps that shall be undertaken to evaluate the impacts of the site generated transit demands on the transit level-of-service:

- Evaluation of the site generated transit demands with comparisons to the transit service supplied in the area for all analysis periods and horizons
- Determination of London Transit's plans for transit service to the area;
- Identification of situations/locations and time periods where:
 - Transit service is not provided in the area and is required;
 - The provision of transit service or facilities are desired on site;
 - Demand exceeds residual capacity of the existing transit service. In these cases, times of day, duration and days of week should be specified as applicable;
 - Transit service hours do not coincide with the times when transit demand will be required;
 - It would be beneficial to provide increase transit frequency or service requirements for special events or peak arrival/departure times.

- Identification of pedestrian connections that are required to conveniently access transit services; and
- Identification of impacts on transit operations directly associated with the site generated traffic volumes.

9. TRANSPORTATION SYSTEM IMPROVEMENTS

This section outlines the process of identification of physical and operational transportation system improvements and other measures required to ensure that the impacts associated with proposed development can be mitigated to the satisfaction of the City.

The physical and operational remedial measures recommended in the TIA must address all deficiencies identified through the completion of the tasks outlined in **Section 8** of this document.

9.1 Identification of Required Road Network Improvements

The physical and operational road network improvement requirements identified in the TIA must address and ensure that:

- Site generated traffic does not create conditions in which the capacity criteria summarized in **Section 8** are exceeded;
- Vehicular, pedestrian and cyclist operations and safety are maintained or improved;
- Motorist, pedestrian and cyclist needs and safety are accommodated; and
- Site generated traffic will not have a noticeable adverse impact on existing or proposed residential communities.

Additional analysis shall be provided to demonstrate that the proposed mitigating measures will in fact address the impacts of the site generated traffic. The City requests that functional plans be provided for all recommended road improvements. A to-scale drawing with dimensions illustrating edge of pavement and lane designations is typically required. An exhibit should be provided within the body of the report, which illustrates the proposed physical improvements. **Exhibit 9-1** includes an example of a road improvement graphic. A legend should be provided in the graphic, which identifies network attributes that are "existing" and which are improvements being proposed.

Exhibit 9-1 – Example Road Network Improvement Graphic

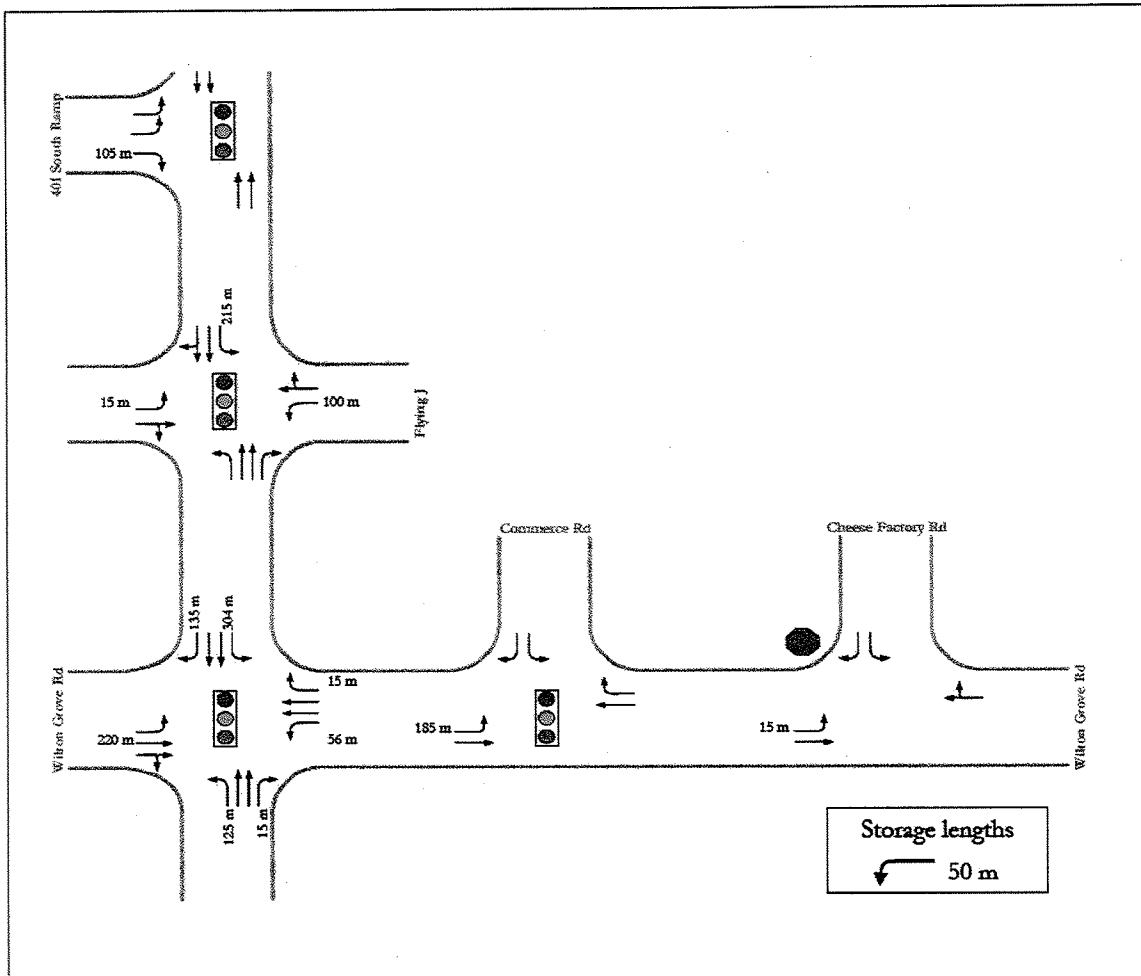

9.2 Identification of Required Transit System Improvements

The physical and operational transit system and service improvement requirements identified in the TIA must address and ensure that:

- The existing capacity of the transit service and facilities is capable of accommodating the anticipated site generated transit demand;
- Site generated traffic will not have a noticeable adverse impact on transit operations; and
- There is a provision for the following, if required:
 - Transit service to the area or to the site including potential transit routes;
 - An increase in transit frequency or hours of operation;
 - Special event service; and

- Transit facilities such as terminals, bays or stops.

Additional analysis shall be provided to demonstrate that the proposed mitigating measures will in fact address the impacts of the site generated traffic. The Proponent shall consult with the London Transit Commission to confirm the feasibility of the provision of new/improved transit services.

9.3 Implementation and Funding of Required Improvements

The Proponent must demonstrate that the required improvements are:

- Implemented in conjunction with the planned timing of the development. For example, some roadway improvements may require an environmental assessment prior to implementation. The Proponent must demonstrate that the development will be phased or timed, as necessary, in conjunction with the implementation of transportation infrastructure or service improvements and/or TDM strategies, to ensure that travel supply and demand are kept in balance over time.
- Feasible given existing operational or physical constraints of the road network, transit service or field equipment, i.e., if an advance phase is required at a signalized intersection, then the ability of the controller to accommodate additional phases will need to be verified;
- Adequately funded by City or Proponent funds. The TIA must address what extent the required transportation system or service improvements will be provided or contributed to by the Proponent.

10. SITE PLAN, PARKING AND ACCESS REQUIREMENTS

This section addresses site plan criteria, parking and access locations in order to develop a plan that will be harmonized with the surrounding developments and provide acceptable access and site circulation for all anticipated modes of travel.

Points of consideration with respect to site plan criteria, parking and access are:

- Compliance with the City of London's Access Management Guidelines;
- An evaluation of proposed access points with respect to possible mutual interference with other adjacent or opposed access points shall be undertaken;
- An evaluation of sight-lines to ensure safe conditions in accordance with accepted standards;
- An evaluation of the potential for access and circulation movements with on-site parking, traffic control, drive through facility etc. to severely impact on-site operations or result in vehicle queues extending onto public roadways;
- Demonstration that the parking policies and standards applied to the development are in accordance with City requirements;
- An evaluation of delivery vehicle/courier unloading facilities and access to these facilities with respect to location, size and design. Convenient access shall be provided in order to avoid the possibility of pick-up/delivery occurring on City rights-of-way;

- An evaluation of emergency vehicle access and circulation, including explicit designation of the fire route;
- A description and evaluation of site access provisions for pedestrians and cyclists shall be included with particular emphasis on convenient and safe access to transit services from the existing/planned facilities to the “front door” of the development; and
- A description of the measures taken to make the proposed development or redevelopment, including on-site transit facilities, where appropriate, accessible to persons with personal mobility limitations.

11. DOCUMENTATION AND REPORTING

It is recommended that the format of the TIA follow the guidelines outlined in this document, as applicable. The following is a recommended structure for a standard comprehensive TIA:

- Executive Summary;
- Site/Development Description;
- Study Area;
- Existing Conditions;
- Analysis Periods;
- Background Travel Demand;
- Site Generate Travel;
- Future Travel Demand;
- Future Traffic Operations and Impacts;
- Future Transit Operations and Impacts;
- Improvement Alternatives Required to Mitigate Traffic and Transit Impacts;
- Transportation Improvement Funding
- Functional design drawings; and
- Conclusions and Recommendations.

Three (3) copies of the TIA with technical appendices shall be provided to the City of London for review. An electronic copy of the text material and analysis shall be provided in Adobe Acrobat (pdf) and/or other mutually acceptable file formats (*.dwg, Synchro 6.0, etc.). A technical appendix included under another cover shall be provided in the case where the analysis and other technical materials are too substantial to provide in one document. The City prefers to have large appendix materials provided in electronic format. Where possible, key maps, diagrams, graphs, tables and other exhibits shall be placed adjacent to the relevant text as opposed to an appendix.

APPENDIX A

CERTIFICATE OF AUTHORSHIP/OWNERSHIP

City of London
Transportation Impact Assessment

CERTIFICATE OF OWNERSHIP

Development Name/Reference:

Company or Firm:

Original Submission or Addendum:

Original Report Name:

I hereby certify that the attached document has been prepared accurately and to the best of my knowledge. The assumptions and analysis contained herein have been formulated using sound transportation planning and traffic operations methodologies.

Individual accepting corporate responsibility:

Name:

Signature:

Project Manager (if different than above):

Name:

Other Individuals involved in the preparation of the assessment and can be contact regarding study content:

Name:

Name:

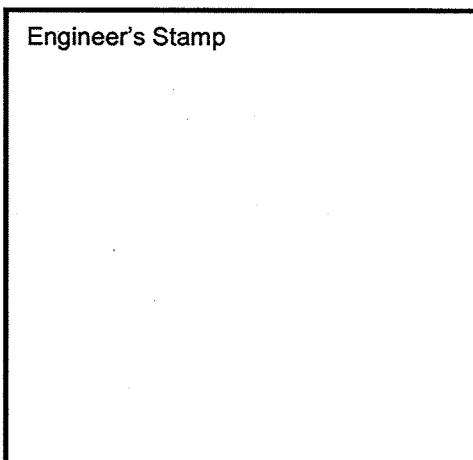

APPENDIX B

ASSESSMENT PROCESS FLOW CHART

City of London
TRANSPORTATION IMPACT ASSESSMENT GUIDELINES

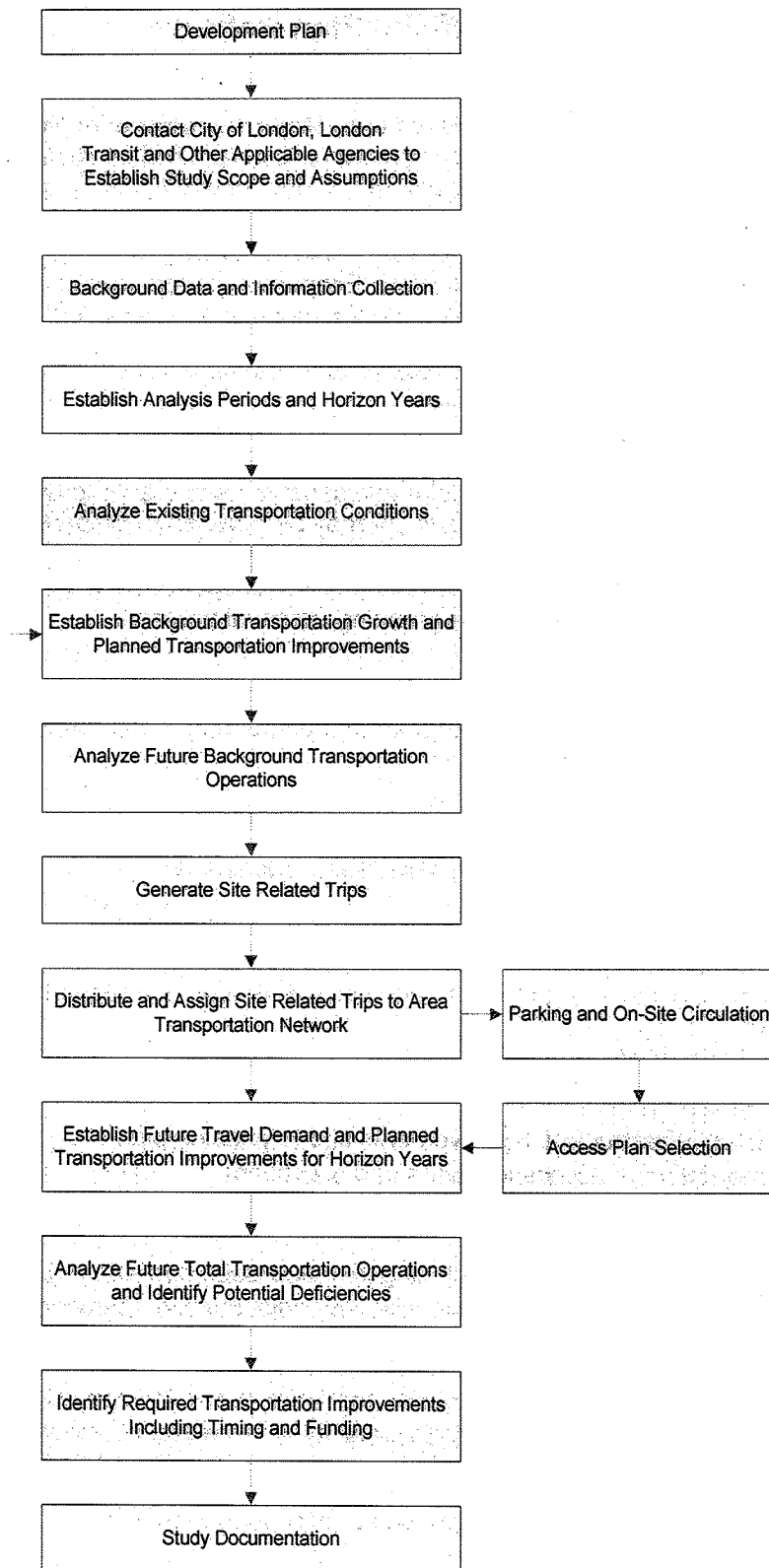

--	--

Appendix "C"

Official Plan Policies

18.2.7. Road Improvements Associated with Major Development Proposals

Council, in its evaluation of major development proposals, shall consider the potential impact of the development on the safety, efficiency and volume of traffic flow on adjacent streets. Developers may be required to contribute to the cost of road improvements which, in the opinion of Council, are necessary to provide for safe vehicular turning movements to and from the site, and to minimize the disruption to traffic flow. Examples of such improvements may include, but not be limited to, road channelization/auxiliary turn lanes to provide left/right turn lanes, and the construction of raised medians.

(Subsection 18.2.7 amended by OPA No. 88 - OMB Order No. 2314 - approved 99/12/23)

(Subsection 18.2.7. amended by OPA 438 Dec. 17/09)

Transportation Impact Assessment

To assist Council in its consideration of traffic concerns and road improvement needs related to a major development proposal, an applicant may be required to prepare a transportation impact assessment. **Council shall adopt Transportation Impact Study Guidelines pursuant to section 19.2.2. of this Plan.** The preparation of a Transportation Impact Study shall be required at the following stages of the planning approval process.

(Section 18.2.7. amended by OPA 438 Dec. 17/09)

Area Plan & Secondary Plan

Identification of transportation infrastructure and operational improvements associated with area wide development potential.

(Added by OPA 438 Dec. 17/09)

Plan of Subdivision

- Arterial and collector roadway requirements and operations
- Phasing plan
- Transportation infrastructure improvements tied to phasing plan
- General description of access locations and operations
- Allocation of responsibility for funding and implementation of transportation infrastructure improvement

(Added by OPA 438 Dec. 17/09)

Site Plan • Phasing Plan

- Transportation infrastructure improvements tied to phasing plan
- General description of access locations and operations
- Allocation of responsibility for funding and implementation of transportation infrastructure improvements
- Access location and operations, including joint accesses between adjacent properties
- Site specific impacts on road network including adjacent site operations

(Added by OPA 438 Dec. 17/09)

18.2.6. Intersection and Access Policies for Arterial and Primary Collector Roads

The efficiency, safety and traffic carrying capacity of freeways, expressways, arterial, and primary collector roads shall be protected by minimizing the number and spacing of intersecting streets and access points.

(Subsection 18.2.6. amended by OPA No. 88 - OMB Order No. 2314 - approved 99/12/23)

Intersections with Local Streets

i) The design of residential plans of subdivision shall discourage the intersection of local streets with freeways, expressways, arterial or primary collector roads.

(Clause i) amended by OPA No. 88 - OMB Order No. 2314 - approved 99/12/23)

Intersection Separation

ii) To the extent feasible, the intersection of a new primary collector or secondary collector road with an arterial road shall provide sufficient separation from the nearest major intersection to allow for the efficient operation of traffic control devices. The Zoning Bylaw may include

--	--

minimum intersection separations to allow for the efficient operation of all modes of transportation at intersections.

(Clause ii) amended by OPA 438 Dec. 17/09)

Restricted Areas

iii) Preferred land uses along arterial or primary collector roads are higher intensity uses with minimum access requirements. Nevertheless, where lands adjacent to an arterial or primary collector road are to be subdivided or severed for the purpose of low density residential development, suitable measures that would prohibit vehicular access from individual properties to the arterial or primary collector road shall be provided. Such measures may include a system of service roads, or looped local roads located parallel to the arterial or primary collector, or a system of common/joint access arrangements with adjacent properties, or where alternative land use or road layout options are not appropriate, reverse lotting. Council may adopt Access Management Guidelines to further control access along arterial and primary collector roads;

(Clause (iii) replaced by OPA No. 88 - OMB Order No. 2314 - approved 99/12/23 Amended by OPA 211 - 01/02/05)
(Clause iii) amended by OPA 438 Dec. 17/09)

Common Access

iv) The subdivision or severance of land adjacent to an arterial or primary collector road, for purposes other than low density residential development, shall minimize the number of access points to the arterial or primary collector road through measures such as the provision of common driveways or a service road. Driveways v) Limitations on the number, spacing and design of driveways, and requirements for the development of common driveways may be applied to the development of lands adjacent to arterial or primary collector roads through the site plan approval process.

Controlled Access By-law

vi) Council may pass a by-law(s) for the purpose of designating sections of arterial or primary collector roads as controlled access roads.

Transit Supportive Design

vii) For residential lands abutting an arterial road, pedestrian access shall be provided at a maximum spacing of 500 metres with a maximum spacing of 1,000 metres between intersecting roads.

(Clause vii) added by OPA No. 88 - OMB Order No. 2314 - approved 99/12/23)

Access Management

viii) **Council shall adopt Access Management Guidelines** pursuant to Section 19.2.2. of this Plan that are to be used in the review of all development applications that involve access to arterial and/or collector roads, including intersection separations.

(Clause viii) added by OPA 438 Dec. 17/09)

19.2.2. Guideline Documents

Council may adopt guideline documents to provide detailed direction for the implementation of Official Plan policies. Guideline documents proposed pursuant to these policies and adopted by Council, shall be added to the list in Section 19.2.2.ii). Provincial guideline documents are also used in the implementation of Official Plan policies.

(Section 19.2.2. amended by OPA 438 Dec. 17/09)

Purpose

i) Guideline documents will be initiated by Council and may contain policies, standards, and performance criteria that are either too detailed, or require more flexibility, in interpretation or implementation, than the Official Plan would allow. Depending on the nature of the guideline document, they will provide specific direction for the preparation and review of development proposals, the identification of conditions to development approval, or the planning of improvements to

Agenda Item # Page #

--	--

public services and facilities.

Content

ii) Guideline documents may be adopted by Council to assist with the implementation of any aspect of the Official Plan. In particular, guideline documents shall be adopted to assist with the implementation of any aspect of the Official Plan for the following, but are not limited to the following:

(Clause ii) amended by OPA No. 88 - OMB Order No. 2314 - approved 99/12/23)

(a) Site Plan Control Guidelines;

(b) Subdivision Design Guidelines;

(c) Road Access Guidelines;

(d) Noise and Vibration Attenuation Guidelines;

(e) Master Drainage Plans;

(f) Stormwater Management Guidelines;

(g) Erosion Control Guidelines;

(h) Conservation Master Plans for Environmentally Significant Areas;

(i) Urban Design Guidelines;

(j) The City of London 2005 Inventory of Heritage Resources;

(Amended by OPA No. 413 approved 07/07/23)

(k) Descriptions of Potential Heritage Conservation Districts;

(l) Subwatershed Planning Studies;

(Sub-clause (l) added by OPA No. 88 - OMB Order No. 2314 - approved 99/12/23)

(m) Ecological Buffers and Development Setback Guidelines;

(Sub-clause (m) added by OPA No. 88 - OMB Order No. 2314 - approved 99/12/23)

(Amended by OPA 438 Dec. 17/09)

(n) Environmental Management Guidelines;

(Sub-clause (n) added by OPA No. 88 - OMB Order No. 2314 - approved 99/12/23)

(o) Guidelines for the identification of Cultural Heritage Landscapes; and

(p) Cultural Heritage Landscape Guidelines.

(OPA No. 269 - approved 03/02/17)

(q) Bicycle Master Plan

--	--

(OPA No.368 - approved 05/10/3)

(r) Old East Heritage Conservation District Plan and Guidelines.

(OPA No. 390)

(s) Guideline Document for the Evaluation of Ecologically

Significant Woodlands (March 2006) (OPA No. 401)

(t) Sunningdale North Area Plan. (OPA No. 410)

(u) West Woodfield Heritage Conservation District Plan and Guidelines (OPA #446)

(v) Dingman Drive (Industrial) Area Plan (OPA 451)

(w) Dingman Drive Industrial Area – Urba Design Guidelines

(OPA #451)

(x) City of London Placemaking Guidelines – November 2007

(OPA 452)

(y) W12A Landfill Area Plan (OPA 462)

(z) Environmental Impact Study Guidleines;

(aa) Environmentally Significant Area Identification and Boundary Delineation Guidelines;

(ab) Significant Woodland Evaluation Guidelines;

(ac) Plant Selection Guidelines for Environmentally Significant Areas, Natural Heritage Areas and Buffers;

(ad) Community Energy Plan;

(ae) Sustainable development and green building initiatives;

(af) Transportation Master Plan;

(ag) Transportation Impact Study Guidelines;

(ah) Access Management Guidelines;

(ai) Facility Accessibility Design Standards;

(aj) Tree Preservation Guidelines; and

(ak) Small Lot Subdivision Design Guidelines.

(Clauses (z) to (ak) added by OPA 438 Dec. 17/09 and renumbered under Section 19.12.8. i) of the Official Plan)

Status

iii) Guideline documents will be adopted by resolution of Council. Development proposals shall be reviewed to determine their conformity with the provisions of any applicable guideline document and conditions may be imposed upon the approval of the development. Council may allow a reduction, change, or waiver of the provisions of a guideline document if it is of the opinion that such action is warranted and that the general intent of the Official Plan will be maintained.

Public Record

iv) A record will be maintained of the

Agenda Item # Page #

--	--

guideline documents (and any associated modification) that have been adopted by Council under Section 19.2.2. Copies of all adopted guideline documents will be made available and accessible to the members of the public.

(Clause iv) added by OPA 438 Dec. 17/09)

Public Participation and Review

v) The preparation of a guideline document will include provisions to encourage input from agencies, associations, and individuals that have an interest in the subject matter. Before adopting a guideline document, Council will hold a public meeting to provide for input from interested parties.

(Clause v) renumbered by OPA 438 Dec. 17/09)