

DRAFT
City of London

Downtown Design Manual

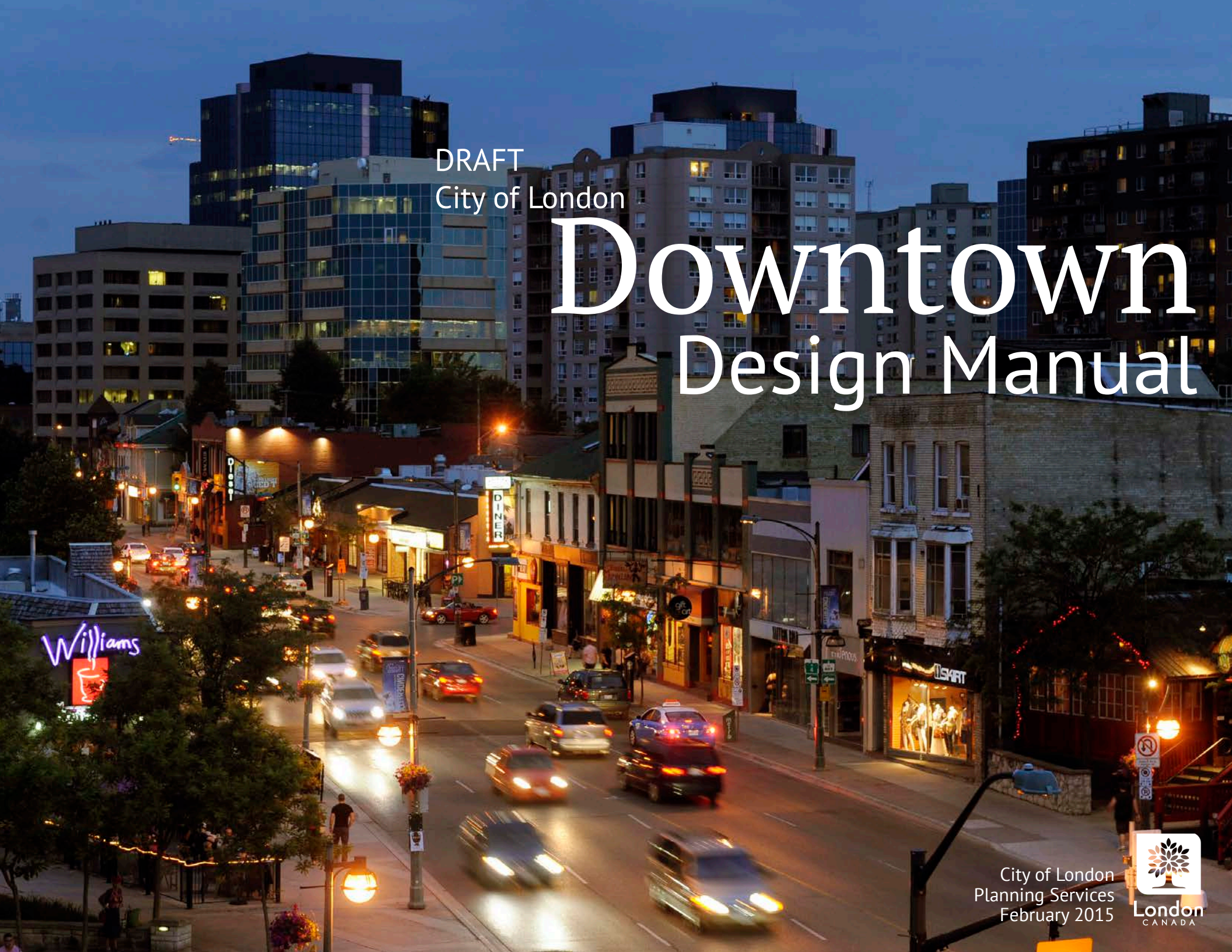

City of London
Planning Services
February 2015





Introduction

London's Downtown is a vital component within the fabric of the city. It is the economic and cultural core of London and an important focal point for intensification. The London Plan, the City's new Official Plan, places the Downtown as the top priority for residential intensification, office development, infrastructure renewal and the revitalization of public and cultural spaces.

This Downtown Design Manual will help to implement a number of policies related to the Downtown. It should be used in combination with the Official Plan, London's Downtown Plan and the Downtown Heritage Conservation District Plan.

The purpose of the Downtown Design Manual is to guide the development of both public and private development projects in the Downtown. This Manual should be referenced for all new and retrofit development projects in the private realm as well as any road reconstruction and public space projects that will be undertaken on public property. Policies related to temporary installations and seasonal events, such as patios and sidewalk markets, are also included.

London's Downtown Plan

Much of the design guidance in this document will play a roll in the implementation of London's Downtown Plan. In particular, these guidelines will assist in achieving the vision and character for many of the streetscape and public space designs outlined in the Transformational Projects.



Overview

Structure

The Downtown Design Manual is divided into the following sections:

1. Streetscape Design
2. Built Form and Site Design
3. Patio Design

It is anticipated that other guideline documents may be developed and added to this manual to include items such as alleyway projects, temporary markets and significant public open spaces like the train station gateway project, or the Forks of the Thames revitalization.

Urban Design Review

All Official Plan and Zoning Bylaw amendments, as well as all Site Plan applications, will require an Urban Design Brief and review by the Urban Design Peer Review Panel, unless deemed unnecessary by the Manager, Urban Design and GIS.

Accessibility for Ontarians with Disabilities Act (AODA)

All projects must be in compliance with the AODA. Where there are conflicts between the contents of this document and AODA, the regulations set out in the AODA will prevail.

Implementation

This Manual will act as guidelines during a number of development review processes including, but not limited to:

- Official Plan Amendments
- Zoning Bylaw Amendments
- Site Plan Applications
- Heritage Alteration/Demolition Permits
- Incentive Programs (Façade Improvements, etc.)





Contents

1.0 Streetscape Design

1.0	Introduction	3
1.1	Streetscape Classifications	5
1.2	Streetscape Framework	13
1.3	Crosswalk & Intersections	17
1.4	Transit	19
1.5	Street Trees	21
1.6	Placement of Street Furniture	23
1.7	Public Spaces	25
1.8	Landmarks & Gateways	29

2.0 Built Form & Site Design

2.0	Introduction	33
2.1	Site Layout	35
2.2	Built Form	37
2.3	Tall Buildings	39
2.4	Architectural Details	45
2.5	Interior Spaces	55
2.6	Parking	57
2.7	Service and Loading	59

3.0 Patio Design Guidelines



1.0

Streetscape
Design



1.0

Introduction

The following Streetscape Design guidance applies to development in the Downtown that is within the public realm. This section's main goal is to guide public works in the publicly owned rights-of-way, as well as within public gathering spaces. This section of the Downtown Design Manual will be used mainly by public employees as they formulate and implement plans within the boundaries of Downtown. It may also be reference by private landowners when intending to provide a portion of their property for semi-public use.

This Streetscape Design manual will influence the following public works:

- Transportation networks and traffic facilities
- Underground and aboveground utility and services renewal
- Sidewalk replacement and maintenance
- Urban parkette design and maintenance
- Streetscape work on and adjacent to privately owned land, when agreements are in place with landowners

Existing Rights-of-Way Framework

The design of public sidewalks is a critical feature of the Downtown environment. Although the City has adopted standards for types of sidewalk pavements, there is no standard design for the paving pattern itself, nor a standard for decorative paving material.

Looking towards future development and improvements in Downtown, it is considered important for the City to adopt a consistent approach to the design and implementation of sidewalk improvements. The resulting consistency will improve the overall visual appearance of Downtown, and improve the ease of maintenance through the use of standardized components.

Factors Affecting Sidewalk Design:

- The existing street right-of-way
- Traffic movement and capacity
- Volume of pedestrians
- Accommodation of transit facilities, including VIA rail
- On-street parking
- The amount of street furniture desired
- Bike lanes and the bicycle network

The street right-of-way is a major determinants of sidewalk design. At present, there are two facets to the street rights-of-way in Downtown: the existing street right-of-way width and the physical road platform breakdown. Existing sidewalk widths in Downtown vary depending on the width of the road surface.

Existing Right of Way Conditions

The general existing conditions in Downtown were as follows:

Right of Way Widths

	ROW Width
Streets East of Wellington and North of Queens	40m
All Other Streets	20m

Road Platform

	Roadway	Sidewalk (each side)
Dundas Street	13m 8m	3.5m 6m
York & Talbot	15m	3m
Richmond & Clarence (south of King)	15m	3m
Most Other Streets	13-14m	3-3.5m

In certain selected instances of high transit use, it may be beneficial to narrow sidewalk widths for short distances to accommodate pull-off areas for bus loading and unloading.

Sidewalk areas should not be reduced to accommodate on-street parking or additional traffic lanes, unless there are no other solutions these problems.

Existing road platforms within Downtown

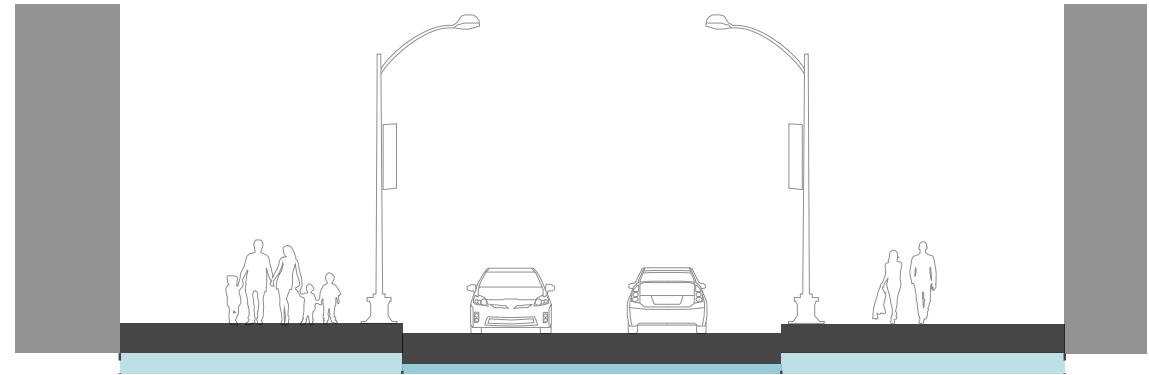

Sections of Dundas St.

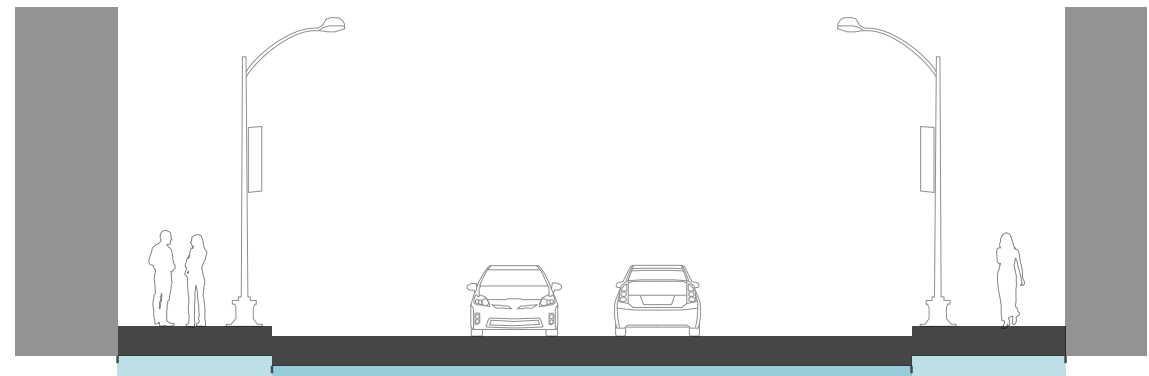

Most Other Streets

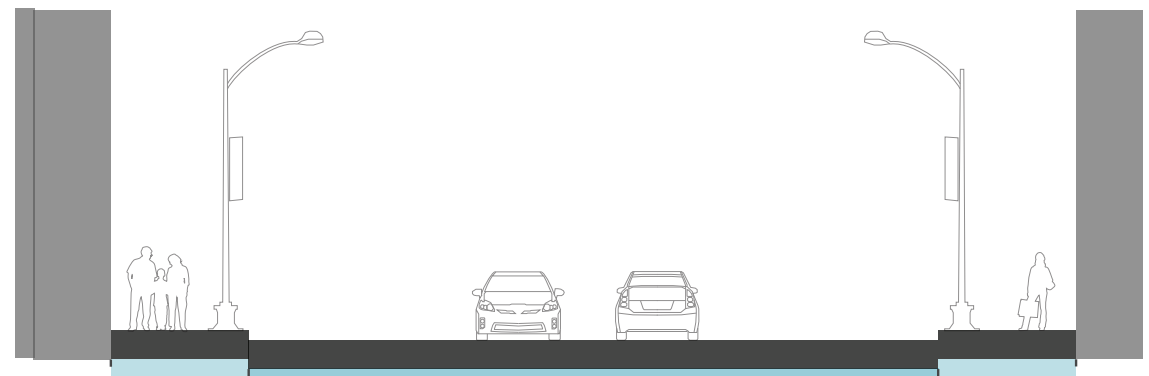

York, and Talbot; Richmond and Clarence (south of King)

1.1

Streetscape Classifications

The following streetscape classifications are based largely on existing uses and level of activities on different streets in the Downtown. These classifications are also influenced by Our Move Forward: London's Downtown Plan and the various transformational projects that will affect the use and design of the streets.

All of the following refer to general design treatments of particular street classifications. Minimum widths for functional considerations are defined in Section 1.2 Streetscape Framework.

Legend

- Special Activity Street
- Major Shopping Street
- Park Frontage/Linkage Street
- Other Streets

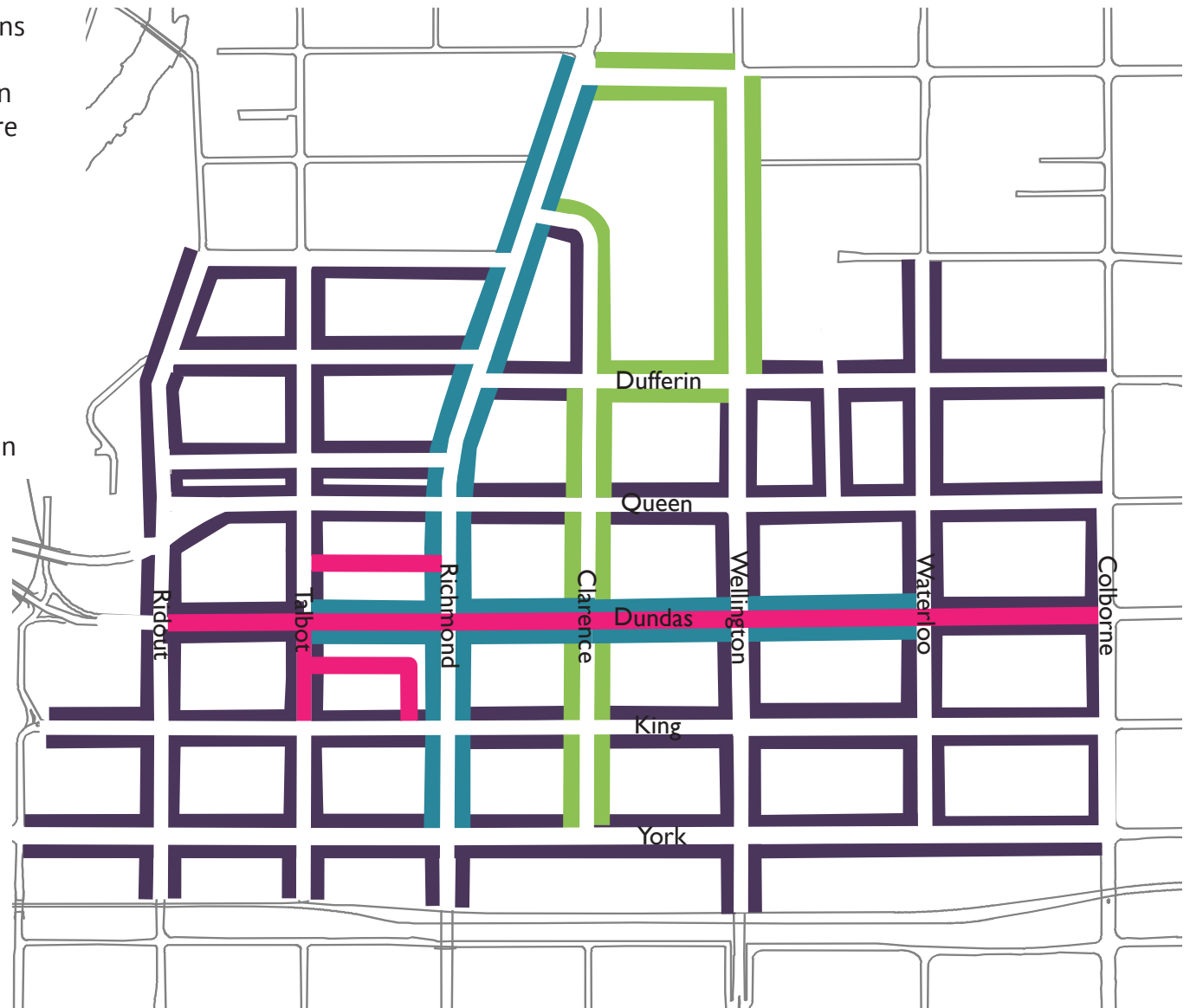

Special Activity Streets

The intent is for these small-scale streets to be the location for certain outdoor events. In order to frame special occasional activities, these streets will be given special paving treatments.

Special Activity Streets in the downtown include:





- Dundas Street
- Talbot Street (Dundas to King)
- Carling Street
- Market Lane

These streets aim to create a seamless public right-of-way environment that allows both cars and pedestrians to share the same space. The right-of-way is to be designed of decorative paving materials, contain no curbs and have little differentiation between the functions of different spaces.

Special Activity Streets will generally consist of the following:

1. Special paving materials, including stamped and/or coloured asphalt and concrete, are to be used for both the sidewalk and roadway portions of the right-of-way.
2. There should be no curbs, or curbs should be flush with the sidewalk and roadway portions, creating a barrier-free surface across the entire right-of-way.
3. Pavement colour and pattern changes should be used to delineate the portion of the street that vehicles may drive on.
4. The pavement pattern and layout of elements such as parking spaces, planter beds, street trees and utilities for Special Activity Streets will be determined through the detailed design, as these streets come up for infrastructure lifecycle renewal.

Legend

-  No Curbs or Curbs Flush with Sidewalk
-  Planter/Parking Locations (to be determined at detailed design stage)
-  Continuous Paved Surface
-  Trees in Grates

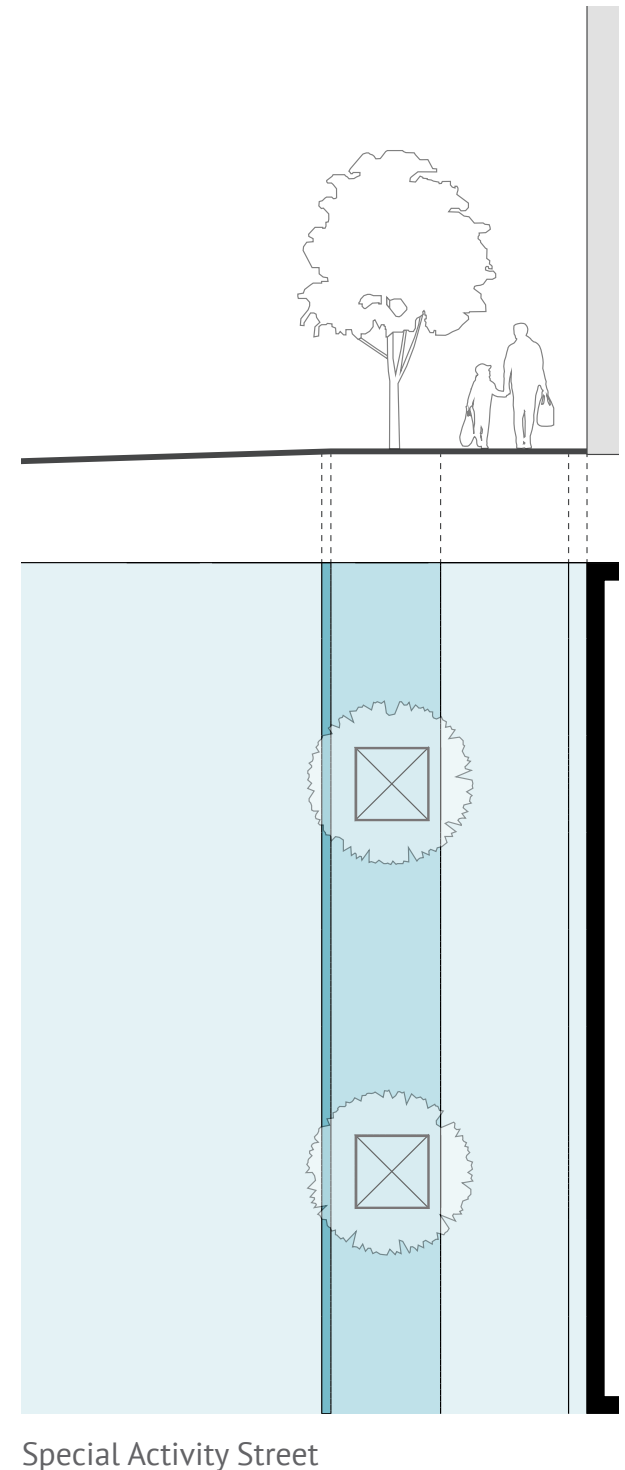

Dundas Place Flexible Street

The Dundas Place Flexible Street project aims to create a seamless public right-of-way environment that allows both cars and pedestrians to share the same space. The flexible street will extend from Ridout Street to Wellington Street. The right-of-way is to be designed of paving materials different than the standard black asphalt, contain no curbs and have little differentiation between the functions of different spaces.

Market District (Talbot Street)

Talbot Street between Dundas and King will become an important connecting feature between Jubilee Square and Rotary Square to create the Market District transformational project, as outlined in London's Downtown Plan.

The goal of the project is to seamlessly join the two public squares so that Talbot can be easily closed for large outdoor events and festivals. The paving treatment of this street segment should continue across the right of way. For this special activity street, curbs will still be used in order to provide a safe pedestrian environment at time when the street is functioning as a normal vehicular road.

Carling Street

Carling Street is an ideal location for restaurant festivals, booksellers market, and other events that would benefit from the small scale of the space.

The street design should prioritize pedestrians over vehicles, while still allowing for vehicle traffic and parking in some areas. Carling Street should be designed with no curbs and all streetscape elements laid out in a way to implement the above vision.

Market Lane

Market Lane is to be the site for outdoor "Market Days", when market activities would spill-out onto the street itself. At present, Market Lane has continuous brick paving on the sidewalk areas that extends onto the driving surface of the street. The street includes standard light fixtures, benches and trash receptacles.

The current treatment should be retained until such time that major street repair is needed. At that point, a detailed design should be established to implement the above street market function.

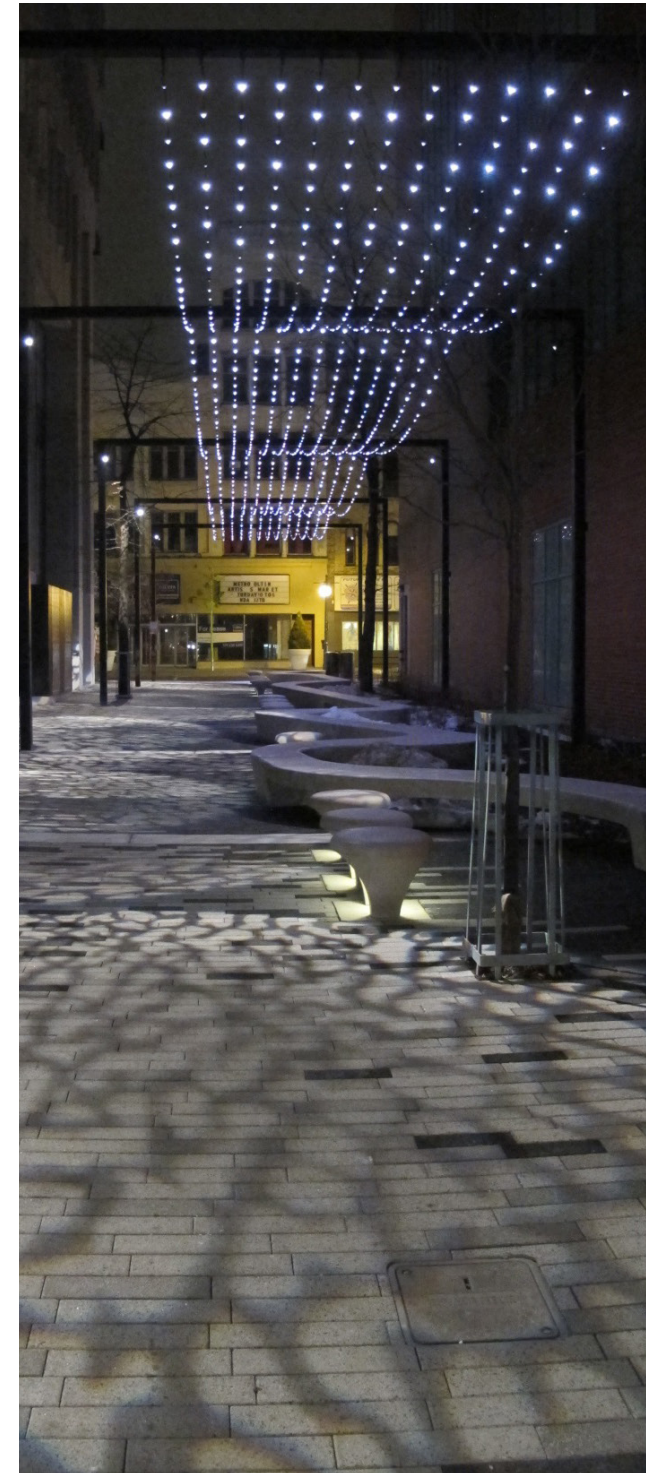

Major Shopping Streets

Major Shopping Streets in the Downtown cater to the highest level of pedestrian traffic and contain a large number of retail, restaurant and personal services establishments. These streets will require wide sidewalks to accommodate pedestrians, patios and displays.

The two Major Shopping Streets in Downtown are:

- Richmond Street
- Dundas Street

Dundas Street is considered both a Major Shopping Street and a Special Activity Street. The design parameters for Dundas are shown in the previous section.

Richmond Walk

Richmond Street from Queens Avenue to York Street will become a pedestrian retail strip, incorporating extra wide sidewalks to accommodate sidewalk patios, cafes, temporary elements such as clothing racks and displays, as well as extra space for neighbourhood-initiated sidewalk sales and outside market events.

The sidewalk paving pattern and arrangement of planters, street furniture, utilities and other streetscape elements will be coordinated and decided upon by Engineering, Transportation and

Urban Design staff at the time that the infrastructure project comes up for renewal.

1. The placement of street trees, planter beds and utilities, as well as the width of the sidewalk, should accommodate sidewalk patios, cafes, clothing racks and displays and other temporary elements.
2. A direct walkway should be maintained in front of storefronts. The above mentioned elements, street furniture and transit facilities should not impede the movement of pedestrians.
3. Street trees should be provided within grates or in formal planter bed located and designed to frame patios and outdoor displays.

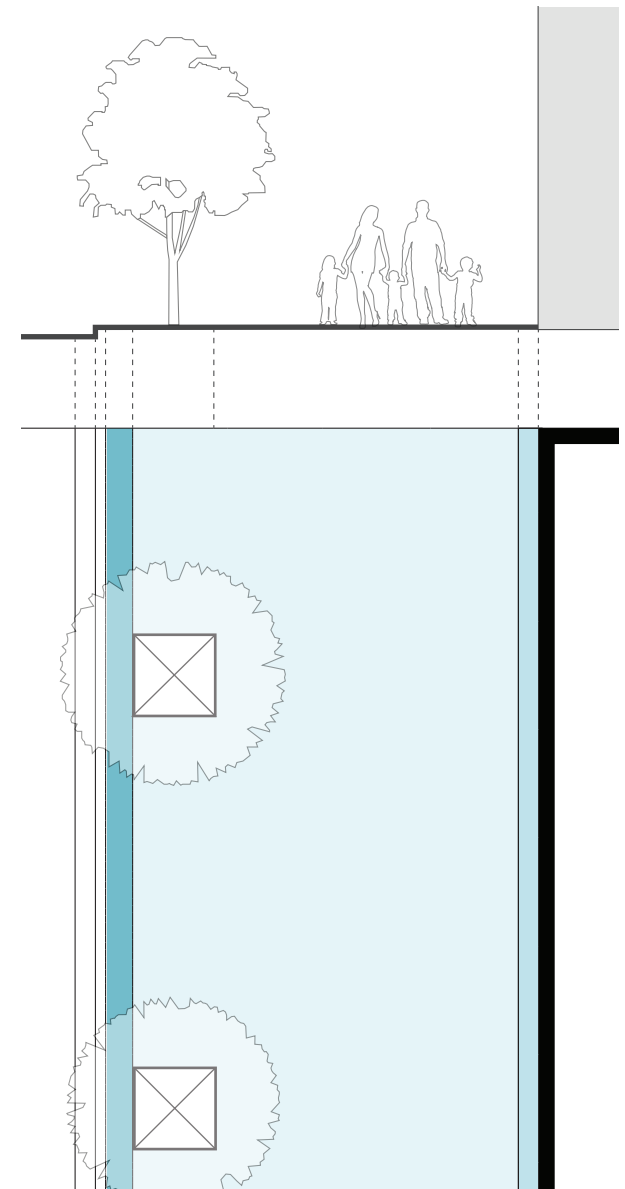

Richmond Walk

Legend

- Continuous Decorative Band
- Continuous Band along Building Face
- Continuous Sidewalk
- ☒ Trees in Grates

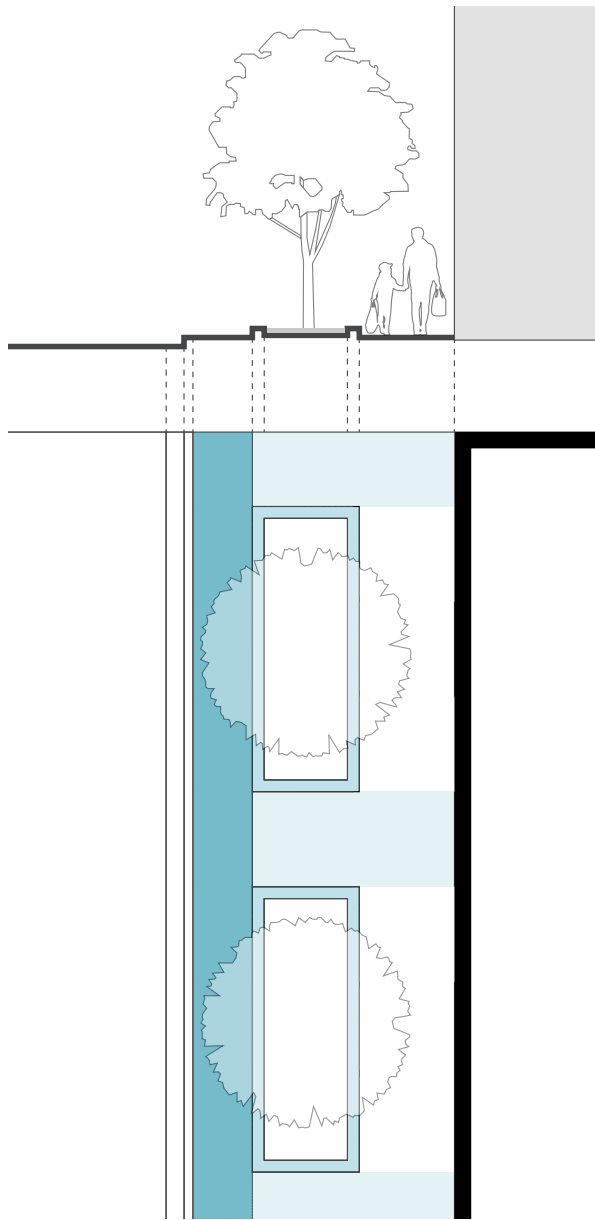

Park Frontage Streets with on-street parking

Legend

- Concrete Band Parallel to Curb
- Curbed Planter Beds
- Paved Walkways Joining Curb-side Band with Sidewalk

Park Frontage / Linkage Streets

Park Frontage Streets include:

- Central Avenue (Richmond - Wellington)
- Dufferin Avenue (Clarence - Wellington)
- Wellington Street (Central - Dufferin)
- Clarence Street

This design includes those streets opposite of Victoria Park, as well as the Clarence Street Connector. The intent is to carry the park-like environment across Wellington St., Dufferin Ave., and Clarence St. To achieve this, a simple sidewalk design is proposed.

This design calls for:

1. A continuous, well-maintained grass planting strip.
2. A double row of street trees, where possible.
3. Simple, wide concrete sidewalks to match those existing in adjacent neighbourhoods.

Where on-street parking is contemplated:

4. A concrete band, minimum 0.4m wide that runs parallel to the curb to provide clearance for opening doors.
5. Landscaping and trees between the curb and sidewalk should be within curbed planter beds.
6. Paved walkways joining the curb-side banding with the primary sidewalk at a maximum of 8m separation.

Clarence Street Connector

Clarence Street from York Street to Victoria Park is proposed to be a key linkage street that should be constructed in accordance with the above guidelines. In addition, any redevelopment surrounding the southern portion of this street should be mindful of the future establishment of a pedestrian bridge over the CN rail line south of York Street.

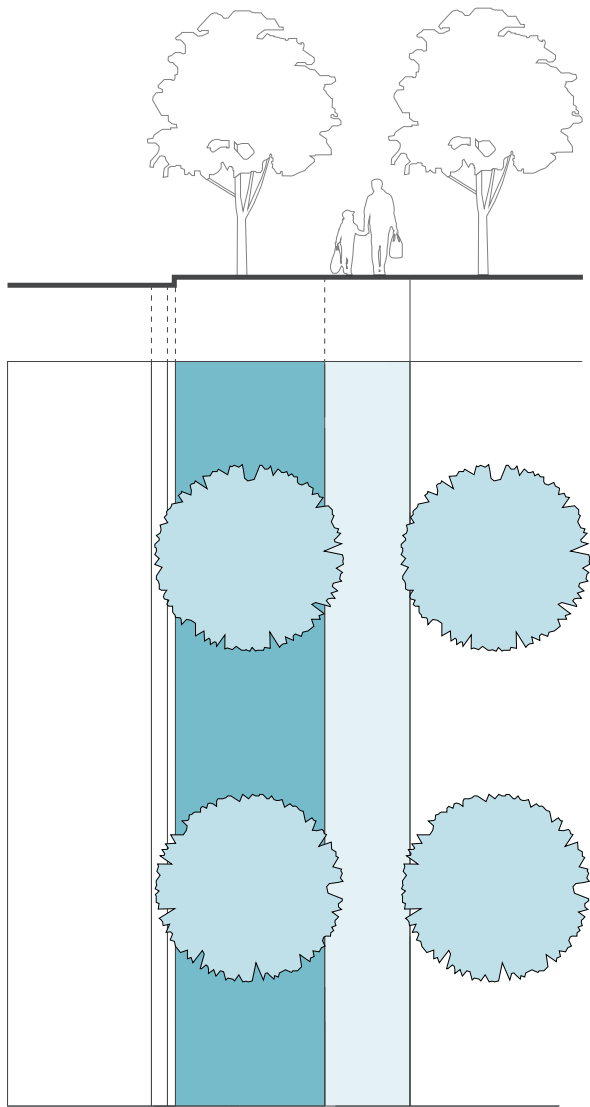

Park Frontage Streets

Legend

- Continuous Planting Strip
- Double Row of Street Trees
- Simple Concrete Sidewalks

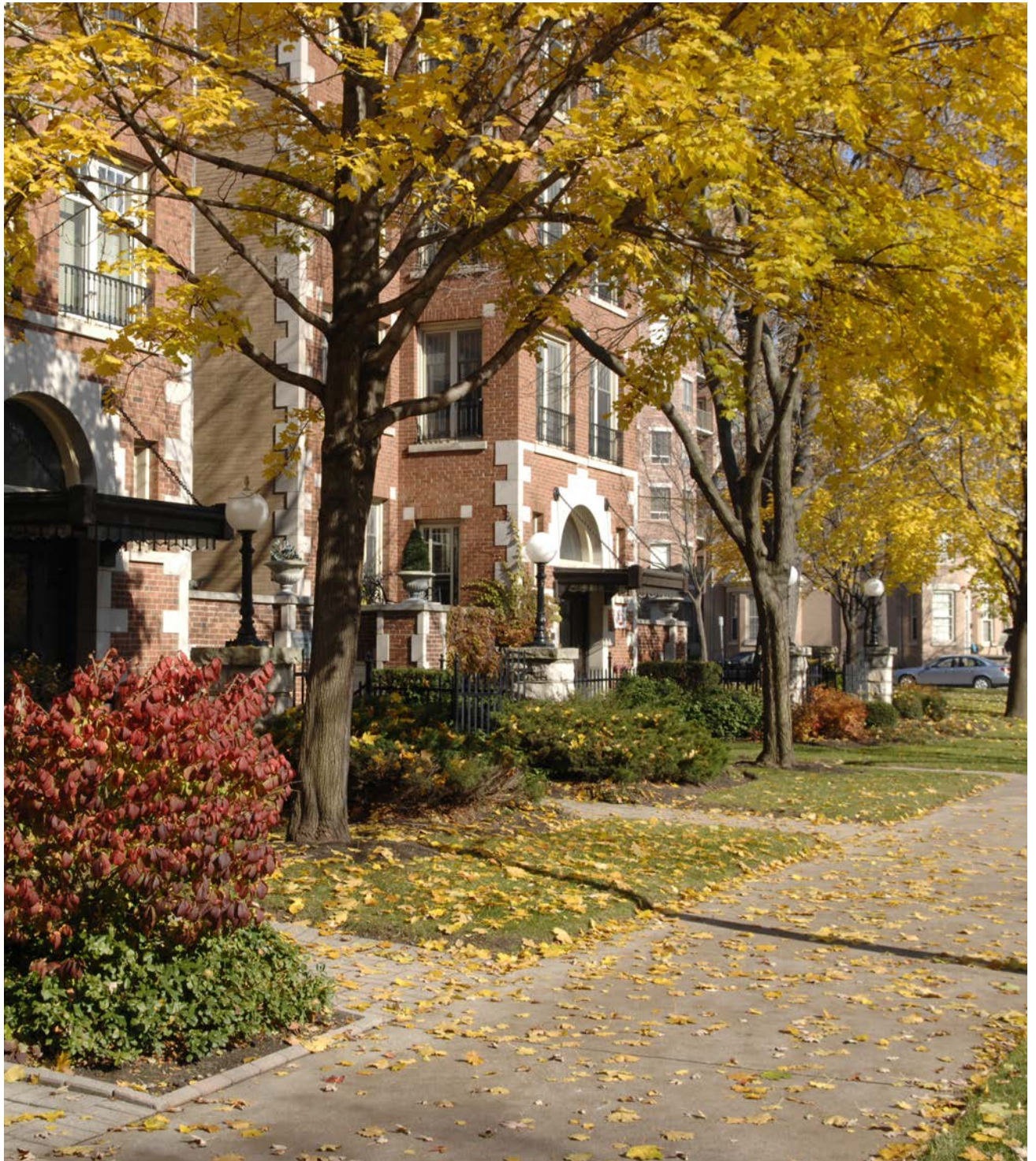

Other Streets

The intent of this sidewalk design is to blend the Downtown environment with the scale and character of surrounding residential streets. To achieve this, a simple sidewalk design is proposed similar to the existing sidewalks around the perimeter of Downtown.

There may be variations to this sidewalk design based on the residential or commercial character of the street.

Commercial Segments

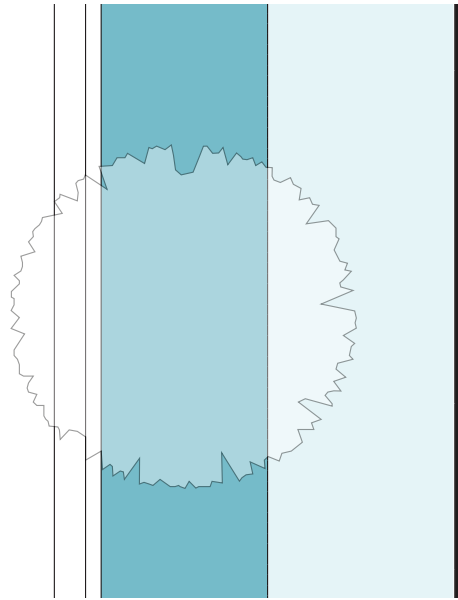

On segments with a commercial character:

1. A continuous concrete sidewalk between the curb and building face with joints running perpendicular to the curb and building facade, generally at 1.5m apart. Cuts should be aligned with tree grates and building edges, where possible.
2. Street trees provided within grates, where space permits.
3. Where on-street parking is contemplated, a concrete band, minimum 0.4m wide that runs parallel to the curb to provide clearance for opening doors.



Other Streets - Residential Segments

Legend

-  Continuous Planting Strip
-  Simple Concrete Sidewalks

Residential Segments

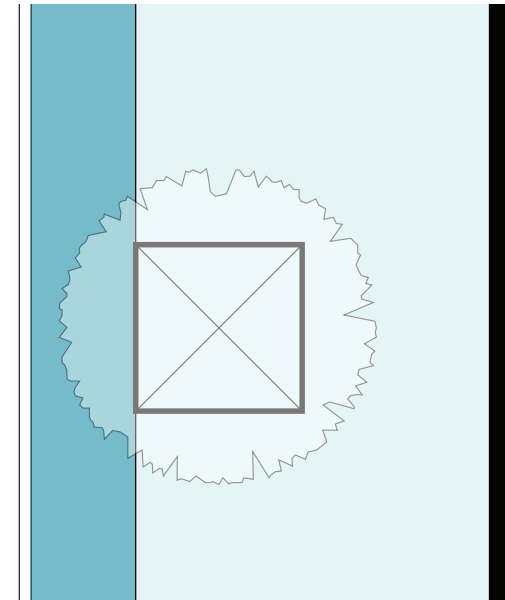

On segments with a residential character:

1. A continuous, well-maintained grass planting strip.
2. Simple concrete sidewalks to match those existing in adjacent neighbourhoods.
3. Street trees provided within the grass boulevard.
4. Where boulevards are wide enough, a double row of street trees should be planted.



Other Streets - Commercial Segments

Legend

-  Concrete Band Parallel to Curb
-  Paved Walkways Joining Curb-side Band with Sidewalk



1.2

Streetscape Framework

Right-of-ways in the Downtown follow certain cross-sectional patterns related to their current and historic functions. Typically, all street segments are made up of the following:

- Vehicular roadway
- Paved sidewalks
- Boulevard space (paved or landscaped)

Depending on the form of development, the composition of right-of-way segments can vary. The following is the dimensional criteria required within various segments.

Minimum for Major Pedestrian Streets (Functional)

Major pedestrian routes include Dundas, Richmond and Wellington Streets. These streets require the most space devoted to pedestrian movement and amenities such as benches, trees, and transit facilities. The minimum width required is 4.85m from the outside edge of the curb.

Where patios are proposed, the *Patio Design Guidelines* should be used to determine the appropriate dimensions for movement.

If it is necessary to adjust these dimensional guidelines, the City should attempt to not overly “clutter” the sidewalk areas with excessive plantings, paving and street furniture. The placement and number of trees and furnishings should be reduced to maintain sufficient room for pedestrian movement.

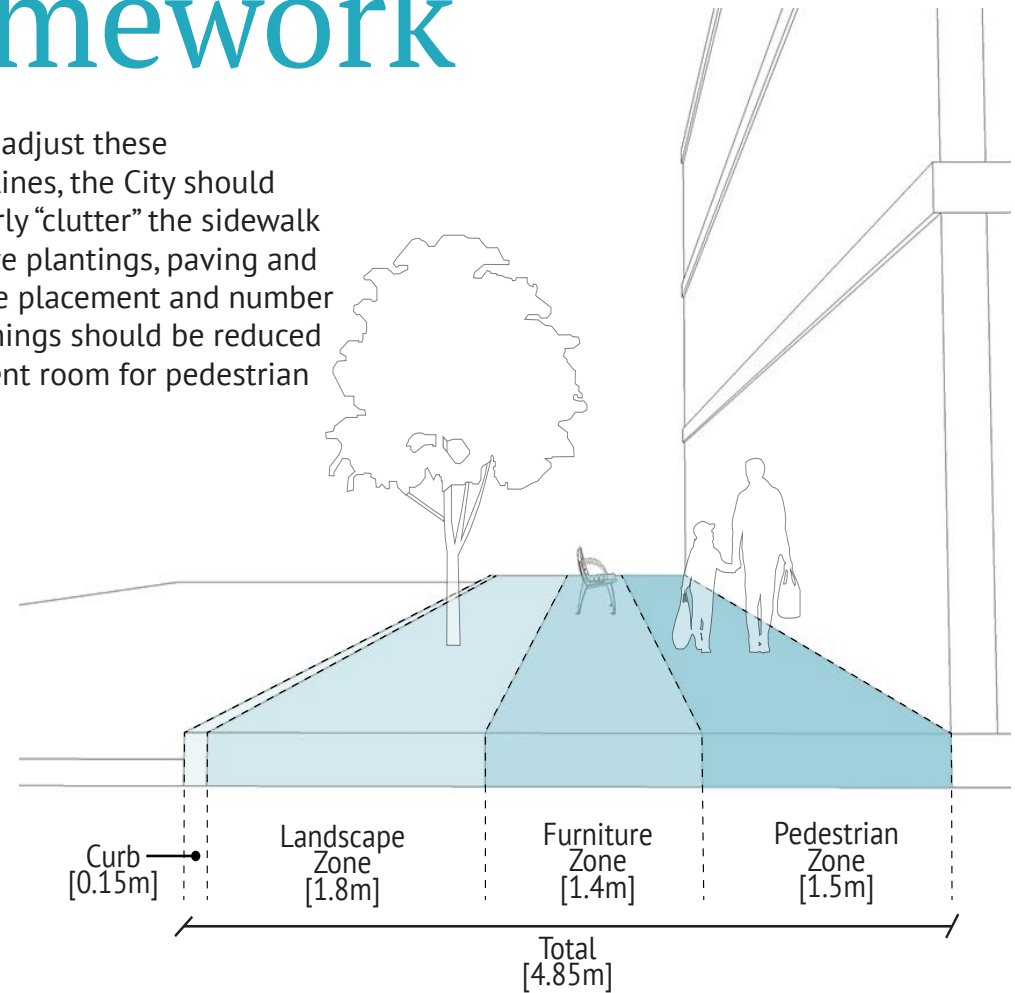

	Total	Curb	Landscape Zone	Furniture Zone	Pedestrian Zone
Minimum for Major Pedestrian Streets	4.85m	0.15m	1.8m	1.4m	1.5m
Minimum to Accommodate Amenities	3.45m	0.15m	1.8m (combined)		1.5m
Absolute Minimum	1.65m	0.15m			1.5m

Minimum to Accommodate Amenities (Functional)

The minimum dimension to provide basic pedestrian necessities and amenities such as street lighting, trees and miscellaneous furniture such as trash receptacles is 3.05m from the outside edge of the curb.

Where sidewalks do not meet these dimensions, the design should minimize obstruction of the pedestrian walking surface. If trees are still desired, curb extensions at mid-block or corner locations, or tree pits covered with perforated concrete tree “grates” should be integrated to maintain as much pedestrian walking surface as possible.

Absolute Minimum (Functional)

The absolute minimum sidewalk width is 1.5m. This width should not be reduced with street furnishings.

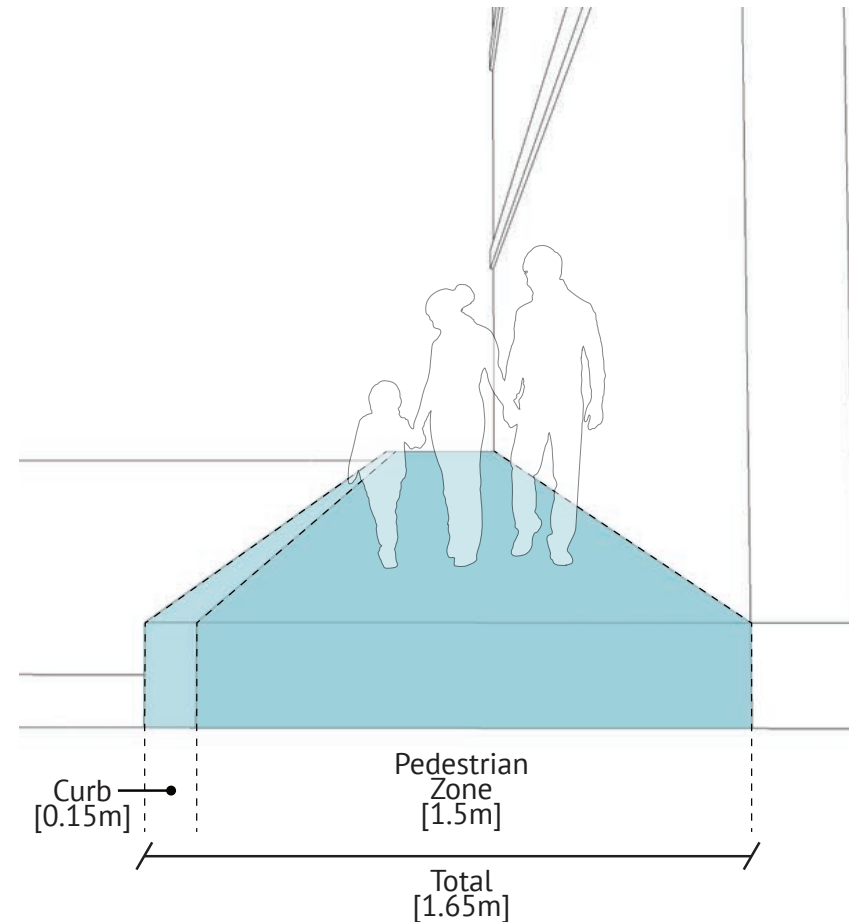
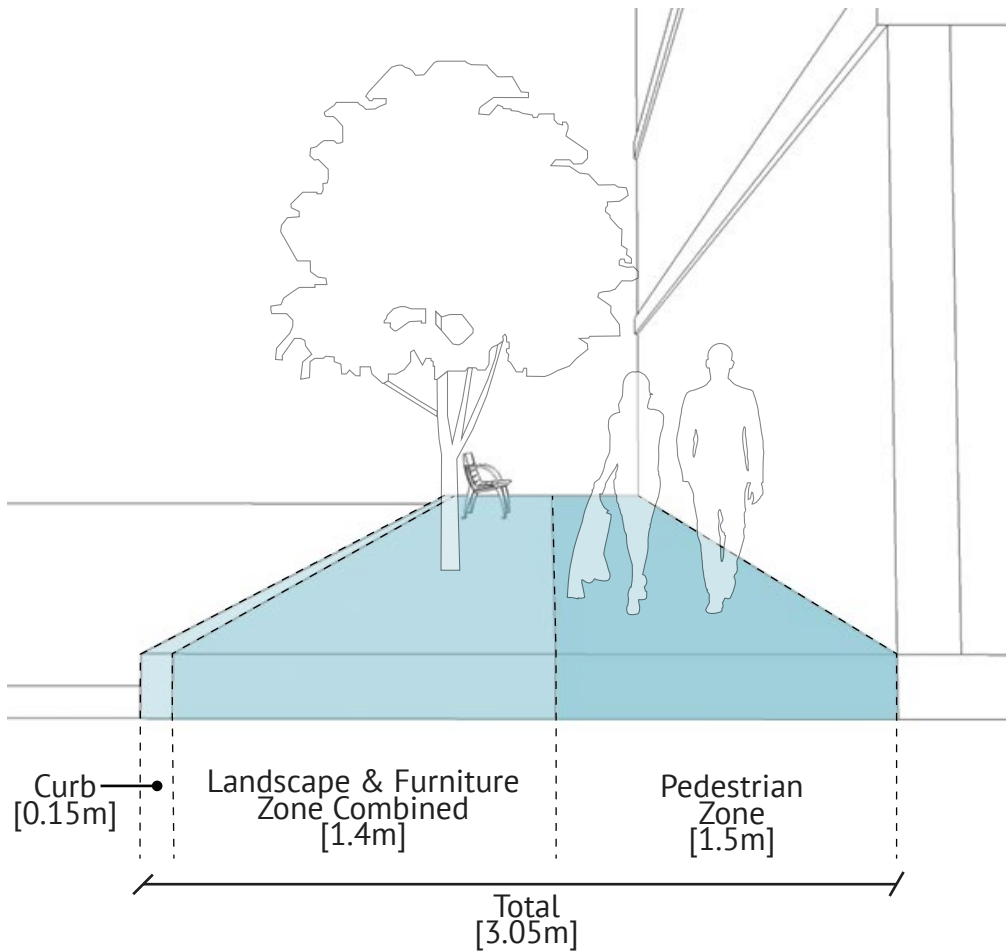

Underground Infrastructure

1. In those situations where major road reconstruction is to be undertaken, consideration should be given to a total streetscape renovation in which utilities may be relocated to facilitate future access and maintenance, as well as to accommodate a more consistent application of the sidewalk design guidelines.
2. Where underground utilities exist, it is recognized that the aboveground treatments may need to be altered for practical reasons.
3. Where it is not possible to alter anything but the sidewalk surfaces, the tree positions indicated in the guidelines will likely have to be adjusted to avoid conflicts with the existing utilities. In those instances, the basic principles established in the guidelines should be followed.
4. An underground topsoil structuring product should be provided to allow for optimal tree health and growth opportunity.
5. Underground conduits should be included for the future provision of fiber optic cables and future communication infrastructure.

Sidewalk Surface Treatment

There are several sidewalk surface treatments that presently exist in Downtown London. The two major materials used in previous improvement projects are brick pavers and standard broom-finish gray concrete.

1. In order to improve lifespan, maintenance and consistency between materials, it is proposed that where brick pavers would have been previously used, a stamped/patterned and coloured asphalt or concrete be used.
2. It is proposed that standard paving materials be adopted by the City for the Downtown
3. The City and private property owners are encouraged to coordinate and use these same materials for improvements adjacent to the sidewalk to further enhance the continuity of the pedestrian environment.
4. Permeable pavement surfaces should be explored during reconstruction projects.

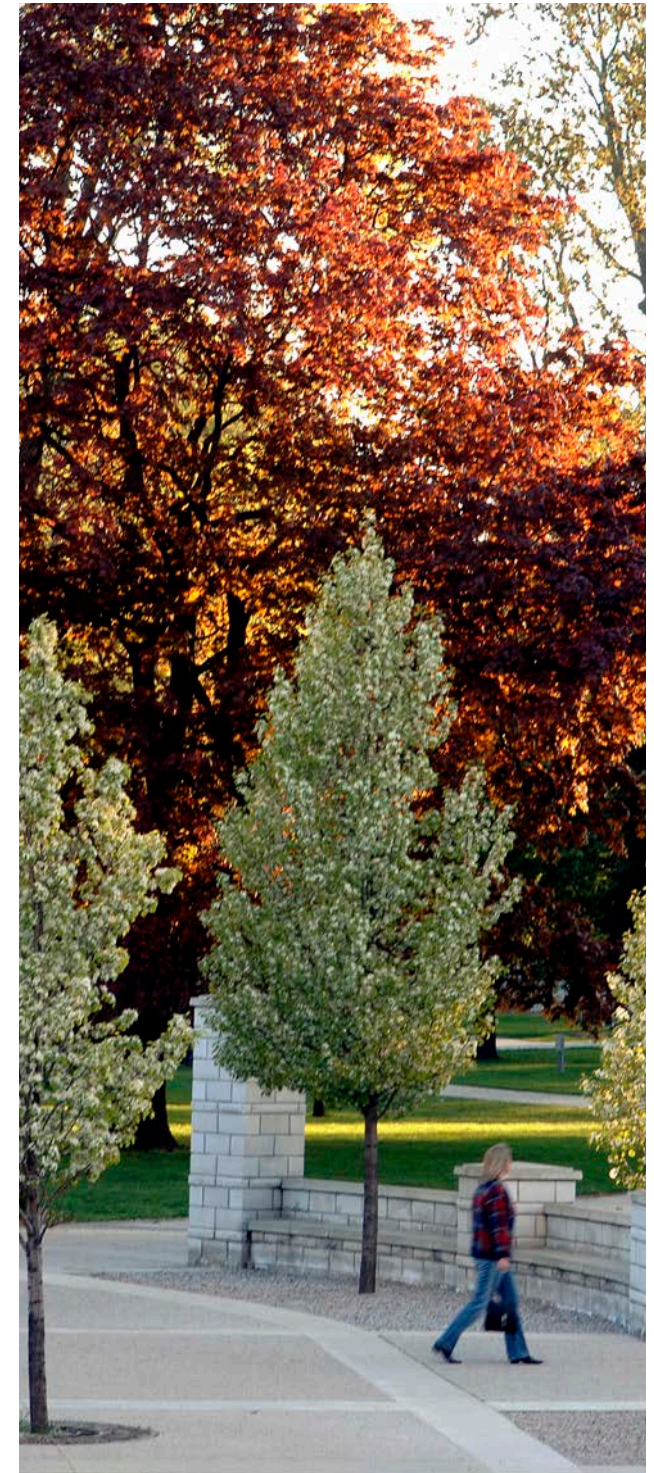

On-Street Parking

On-street parking provides convenient opportunities for drivers to stop in close proximity to Downtown businesses for short trips, while minimizing the occurrence of large surface parking lots in the Downtown.

1. On-street parking is encouraged on streets where the right-of-way is of an appropriate width. Attention should be paid to the surrounding pedestrian environment, ensuring there is adequate sidewalk space around vehicles.
2. On-street parking should be framed with curb extensions at either end to reduce the distance pedestrians must travel to cross the street.

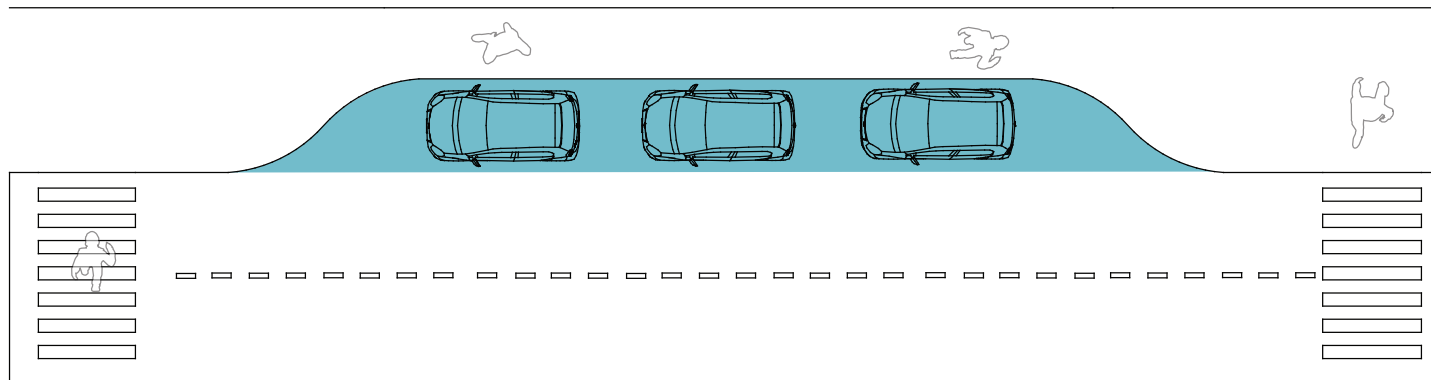

Frame on-street parking with bump-outs

1.3

Crosswalks & Intersections

Crosswalk Treatment

The major intersections with high pedestrian volumes should be developed with special street crossings. Along Dundas Street, there are some existing examples of this, but as with the sidewalk treatment, the application of crosswalk design has not been consistent.

The intersections proposed for this treatment include:

- Wellington and King Streets
- Richmond (at King and Dufferin)
- Dundas Place Flexible Street at all cross-roads
- Carling Street (at Talbot and Richmond)
- Mid-block at major alleyways

Crosswalks should be designed with a simple treatment that provide a visual link across the intersection, and distinguishes the pedestrian surface from the vehicular right-of-way. This should include:

1. A broom-finish concrete walkway, or stamped and/or coloured concrete or asphalt is proposed.
2. Decorative banding, joints and cuts lined up with these elements on the sidewalks.
3. Crosswalks must meet AODA regulations including providing colour and texture changes for pedestrians with visual impairments.

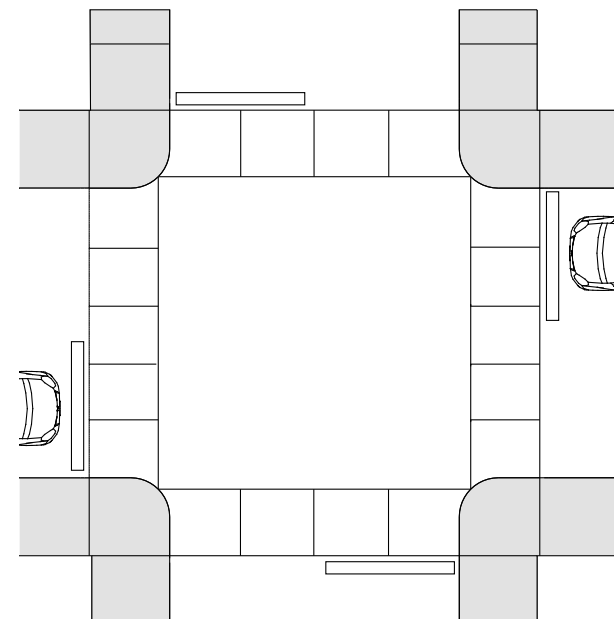

Continue paving patterns through high-traffic crosswalks

Crosswalk Improvements

In preparing streetscape plans, or through capital investments, provision for enhanced pedestrian crossings is encouraged. This can be achieved through:

- Curb extensions at intersections
- Using alternative materials for crossing areas
- Removal of right hand turn lanes, or
- Raised intersections.

If the above improvements are made to any crosswalks, they should also be designed with the special crosswalk treatment described above.

Implementation of such crosswalks would help to enhance the character of the street as a pedestrian district.

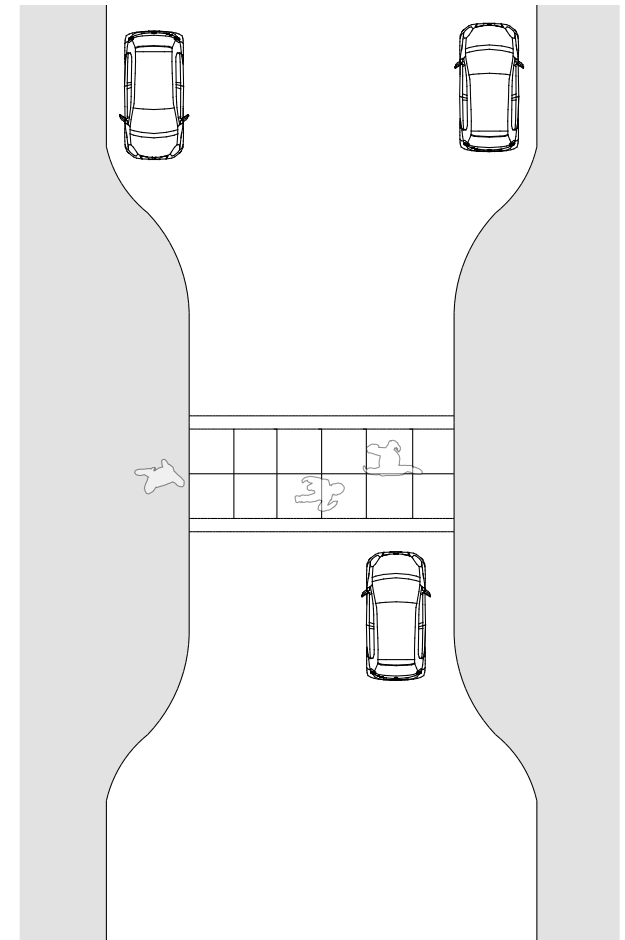

Provide curb extensions for mid-block crossings

1.4 Transit

The Downtown is heavily served by public transit and includes primary transfer points for many local bus routes.

Development in the Downtown should be mindful of the public transit function of certain streets.

1. The right-of-way, as well as private and semi-public spaces should be developed to incorporate the appropriate spaces and features that will promote easy access to, and use of, public transportation.
2. New or redevelopment of large employment sites should incorporate features conducive to transit stops. Large developments on direct routes from Old East Village, Wortley Village, SoHo and Richmond Row should also anticipate future transit stops nearby.



Transit Facility Locations

Transit is an important means of movement into and within Downtown London, and is considered an integral feature of a successful Downtown. Therefore, transit stations and transfer points should be retained in close proximity to the core retail shopping district.

Consideration should be given to removing bus routes from Dundas Street in order to achieve the Dundas Place Flexible Street project.

1. Bus stops should be located in areas where sidewalks are a sufficient width to accommodate the necessary waiting and boarding functions.
2. Heavily utilized routes and transfer stops should be located where sufficient sidewalk exists to provide shelters and/or benches.
3. Where existing sidewalk width does not conform to the minimum proposed dimension the following choices should be pursued: (in order of preference):
 - Relocate the transit stop to a location where sufficient sidewalk width exists, either within the public right-of-way or in building setback areas, subject to negotiations with the private property owner.
 - Widen the sidewalk to the minimum widths, with a sidewalk curb-extension where such a scheme will not reduce or restrict traffic movement.
4. Developers of major new Downtown projects are encouraged to coordinate the ground level plans of their buildings with the LTC, and to provide setback areas or covered arcades which could be used for transit stop facilities.
5. Owners of existing buildings are encouraged to cooperate with the LTC to provide space and/or facilities for existing transit stops.
6. Ensure the public realm provides adequate shelter and waiting areas for transit riders.



1.5

Street Trees

A number of factors will affect the type of street trees selected for use in Downtown. Among these are:

- Tolerance to low nutrient levels of soils
- Tolerance to road salt
- Appropriate sizes for available space
- Health factors (ie. diseases that may be currently affecting certain tree species)
- Species diversification to minimize losses to species-specific diseases
- Canopy spread
- Maintenance considerations
- Flowering and/or colour characteristics
- Tree availability

Because of these variables, it is preferred that the City's Urban Forester select a list of trees which are considered to be suitable for use in Downtown. Due to changing conditions, this list should be reviewed and, if necessary, revised on an annual basis.

General Provisions

The trees selected for Downtown streets should meet the following general guidelines:

1. Trees should be selected to “fit” the overall width of the sidewalk in which they will be placed:
2. Sidewalks less than 3m in width can accommodate only the smallest canopy trees with upright or columnar growth patterns.
3. In sidewalks 3m or less in width, consideration should be given to sidewalk curb extension, or wider spacing of trees so as to not obstruct the space for pedestrian movement.
4. On sidewalks 4.6m or wider, large canopy trees are encouraged to provide shaded walkways.

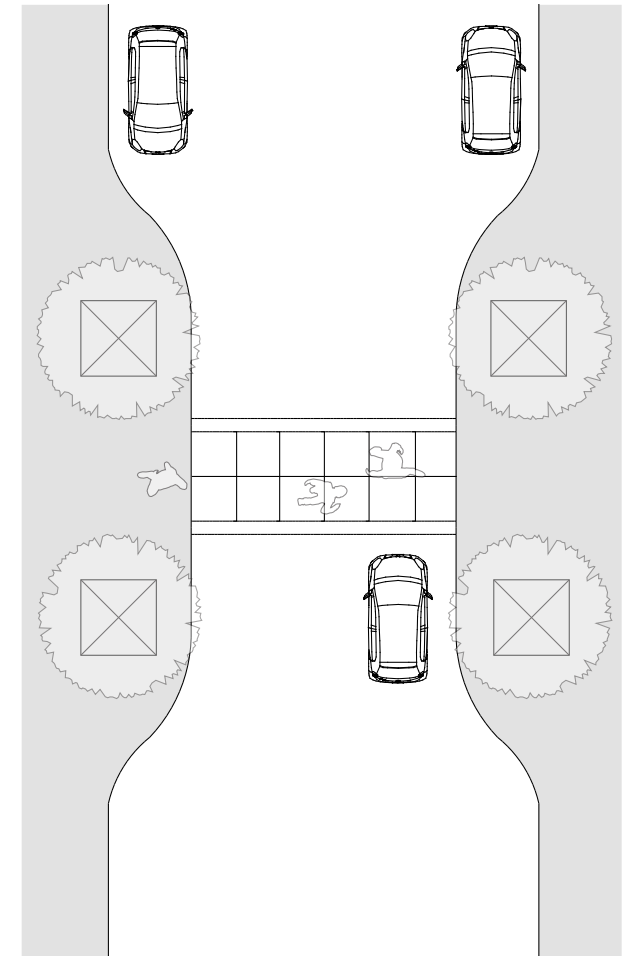

Place street trees in curb extensions when sidewalk widths are too narrow

Planting Guidelines

In addition to selecting appropriate species of trees for certain locations, the following guidelines shall apply to street tree planting.

1. Trees should be protected with “standard” London tree guards when first planted, and guards retained until the trees are established.
2. Open metal tree grates are preferred.
3. Where major street or sidewalk construction is planned, consideration should be given to sub-surface designs that provide as much soil area for tree root growth as possible (ie Silva cells).
4. Since this installation is likely to require relocation of utility lines, it must be coordinated through the City Engineer.
5. Coordinate utilities and tree planting zones through proposed streetscaping plans and/or capital investment to enhance tree growth.
6. Where possible use enhanced planting methods and materials to provide better planting zones and longer term survival.
7. Encourage the use of storm water management technologies to assist with landscape maintenance and reduce overall water usage.



1.6

Placement of Street Furniture

Street furnishings are necessary and desirable elements in the Downtown streetscape environment. Presently there are a variety of furnishings in Downtown. Most notable among these are the benches, trash receptacles and bicycle racks.

Street furnishings include the following:

- Light poles, street identification, traffic lights and traffic regulatory poles
- Trash receptacles and newspaper boxes
- Information kiosks and transit shelters
- Bicycle racks

Selection, location, replacement and maintenance of street furnishings shall be in accordance with the London Plan, Downtown Heritage Conservation District Plan, London's Downtown Plan, and City engineering standards and requirements.

In consultation with the BIA and individual property owners, the City will consider a variety of factors when assessing need and location of various street furniture items.

General Provisions

1. Furnishings should not obstruct clear and direct pedestrian movement along the building face or in pedestrian circulation areas.
2. Furnishings should not be installed where insufficient sidewalk width exists or in areas where they will obstruct sight-lines.

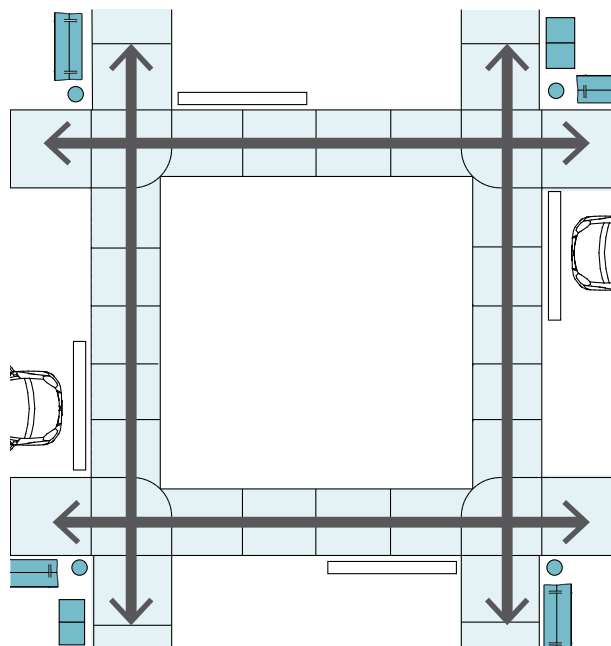

Maintain a clear pedestrian walking surface through intersections.

Curb-side Elements

1. In general, only traffic regulatory signage and poles, street identification signage and light fixtures should be permitted adjacent to the curb area.
2. Where no other location is possible, trash receptacles and newspaper boxes may be placed in the curb-side sidewalk area subject to Heritage, Urban Design and Engineering requirements.
3. Newspaper boxes, bicycle racks and trash receptacles should be kept back from corner locations so they do not obstruct pedestrian movement across the intersection.
4. The preferred location for benches, newspaper boxes, trash receptacles, information kiosks and bicycle racks is in a dedicated area next to the curb, allowing for a continuous pedestrian walkway adjacent to the building face.

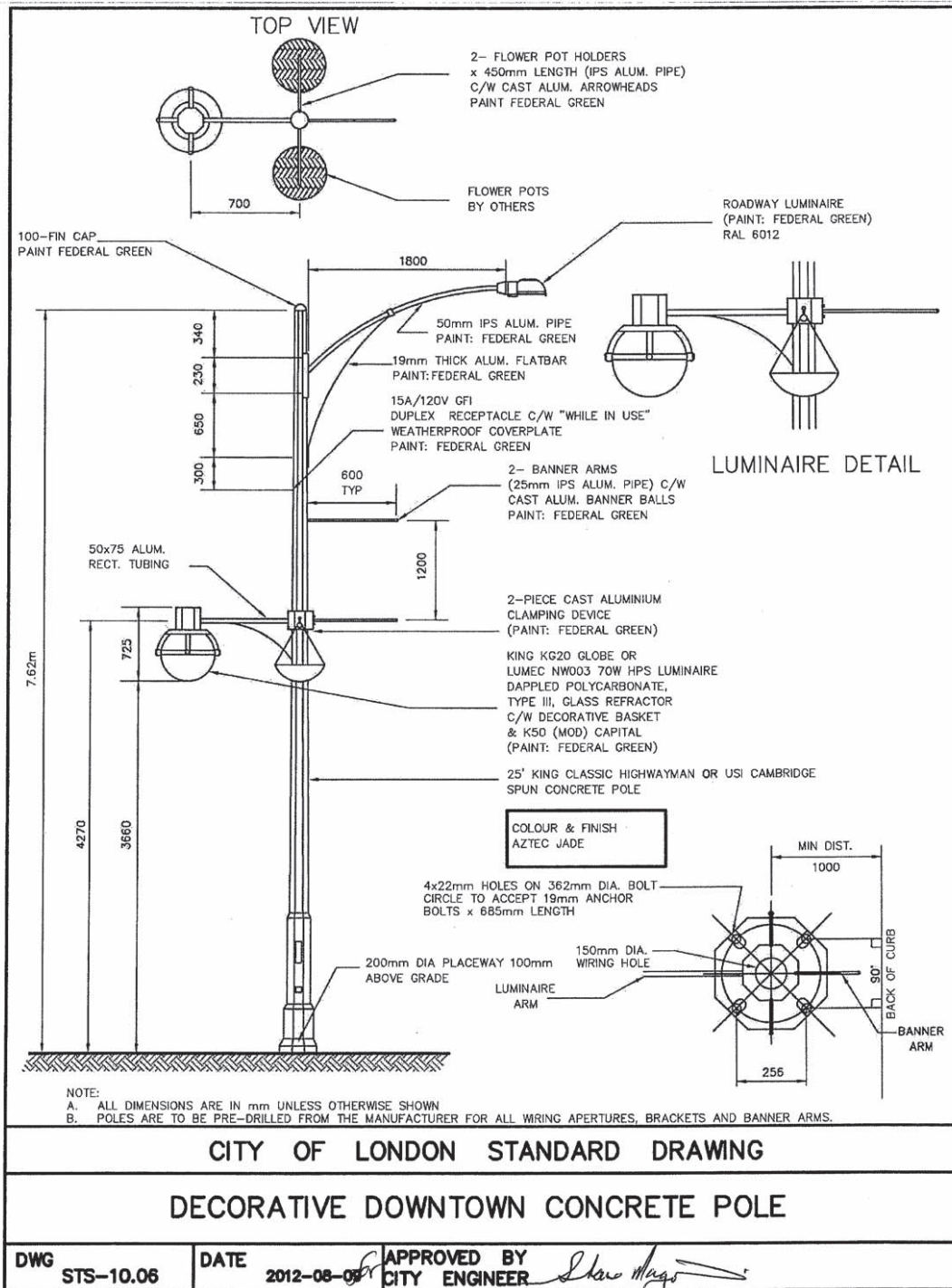

Benches & Seating

5. Benches and seating are desirable in locations where sufficient sidewalk width exists to accommodate them. The addition of benches, and alternative seating areas should be considered in locations:

- Adjacent to crosswalks and corners where other pedestrian amenities such as plazas, landscaped setbacks, and arcades are near by.
- Adjacent to transit stops in areas that receive winter sunshine, and/or are protected from winter winds.



1.7

Public Spaces

Plazas

While the preferred location of buildings is at the property line, project developers may wish to provide larger open spaces at the street level of their projects to create a special visual setting for the building, enhance the entryway, or create places for outdoor dining or other activities.

Plazas may also be created to fulfill open space or lot coverage requirements, or they may be left-over space that is not considered desirable for buildings. In all of these cases, the plazas created return open space back to the public environment along the sidewalks.

The way in which ground level open spaces are designed and positioned can have significant effects on the functionality and character of the street-level environment. The following guidelines encourage the design of plaza spaces that will contribute positively to the functional and aesthetic environment of Downtown.

General Provisions

1. Wind tunnel testing should be undertaken where a plaza is proposed to measure any potential adverse effects on the pedestrian environment. The design should then be modified as necessary to minimize street level wind impacts.
2. In order to permit maximum solar penetration, plazas are encouraged to be located on the north side of the street, facing south.
3. Plazas should be designed with a sense of spatial definition or articulation based on the type of activities to be accommodated within the space(s). Open, non-articulated expanses of paving are generally considered to be inappropriate if they provide no setting for pedestrian-oriented activities.

Spatial definition may include the use of building enclosure, landscape and site elements such as seatwalls, changes in paving material, etc. Enclosure by building elements is often an easy way to provide spatial definition.

4. Plazas serving and entrance courts to new development or as open space amenity areas, are preferred to be developed with active ground level pedestrian related uses near by. Office uses and other activities that do not require or generate pedestrian activity are not appropriate adjacent to plazas.
5. Plazas intended for public use should not be visually cut off from the sidewalk spaces to insure the safety and security of these spaces.
6. Plazas intended for private use only should clearly delineate the boundary between public and private space, while maintaining visual connection for safety.
7. Plazas completely enclosed by buildings should have at least 4 access points from the public realm. They should be designed in keeping with CPTED principles.

Plaza Landscaping

1. Landscaping is encouraged within plaza spaces to expand upon the landscape character provided by street trees in the public sidewalk. The amount and scale of landscaping should reflect the size and orientation of the space, and the amount of sunlight.
2. Plant materials must be selected that will survive in the proposed location. Private developers are encouraged to solicit the advice of the City in the selection of appropriate plant materials to coordinate with City landscape efforts.
3. If landscape elements are in raised planters, the planters should be no more than 0.5m (1.5ft) high, and be incorporated into a seat-wall edge treatment.
4. When landscaping is placed over concrete slab construction, sufficient soil depth, drainage, and irrigation must be provided to ensure the survival of plant materials.

Plaza Paving Materials

1. Paving in plaza areas should use a variation of the adjacent paving patterns and materials proposed in the public sidewalks in order to visually link the spaces together.
2. Where plaza paving materials are not the same as the public right-of-way paving materials, they should incorporate a framing treatment which provides a finished appearance along the sidewalk's edge. Private paving materials should not extend into the public right-of-way.

Relationship of the Plaza to the Street

1. The arrangement of built elements and site topography may influence the vertical location of plazas relative to sidewalks. It is preferred that plazas be at the same grade as adjacent sidewalks to provide for visual and functional connections.
2. Where large changes in the existing grade of the site cannot be accommodated internal to the building, amphitheater or cascading terrace design solutions may be required.



Urban Parkettes & Civic Spaces

Where opportunities arise to redevelop City-owned land in the Downtown, the City of London should consider incorporating urban parkettes and other small civic spaces into the public realm.

The creation of these spaces should consider CPTED principles as well as the individual contexts of the spaces. Where appropriate, street furniture and public art should be included in the design of urban parkettes.

Off-street Pedestrian Trails

There are defined and established multi-use pathways along the Thames River open space system, including the Harris Park area. Beyond these linkages, pedestrian movements are accommodated along brick and concrete sidewalks that are found on all the streets within the Downtown.

1. Additional off-street pedestrian routes should be established when new public spaces are redeveloped.
2. Private developers are encouraged to incorporate off-street pedestrian corridors into the redevelopment of large sites, to provide direct access to important public spaces and the transit system through mid-block connections.

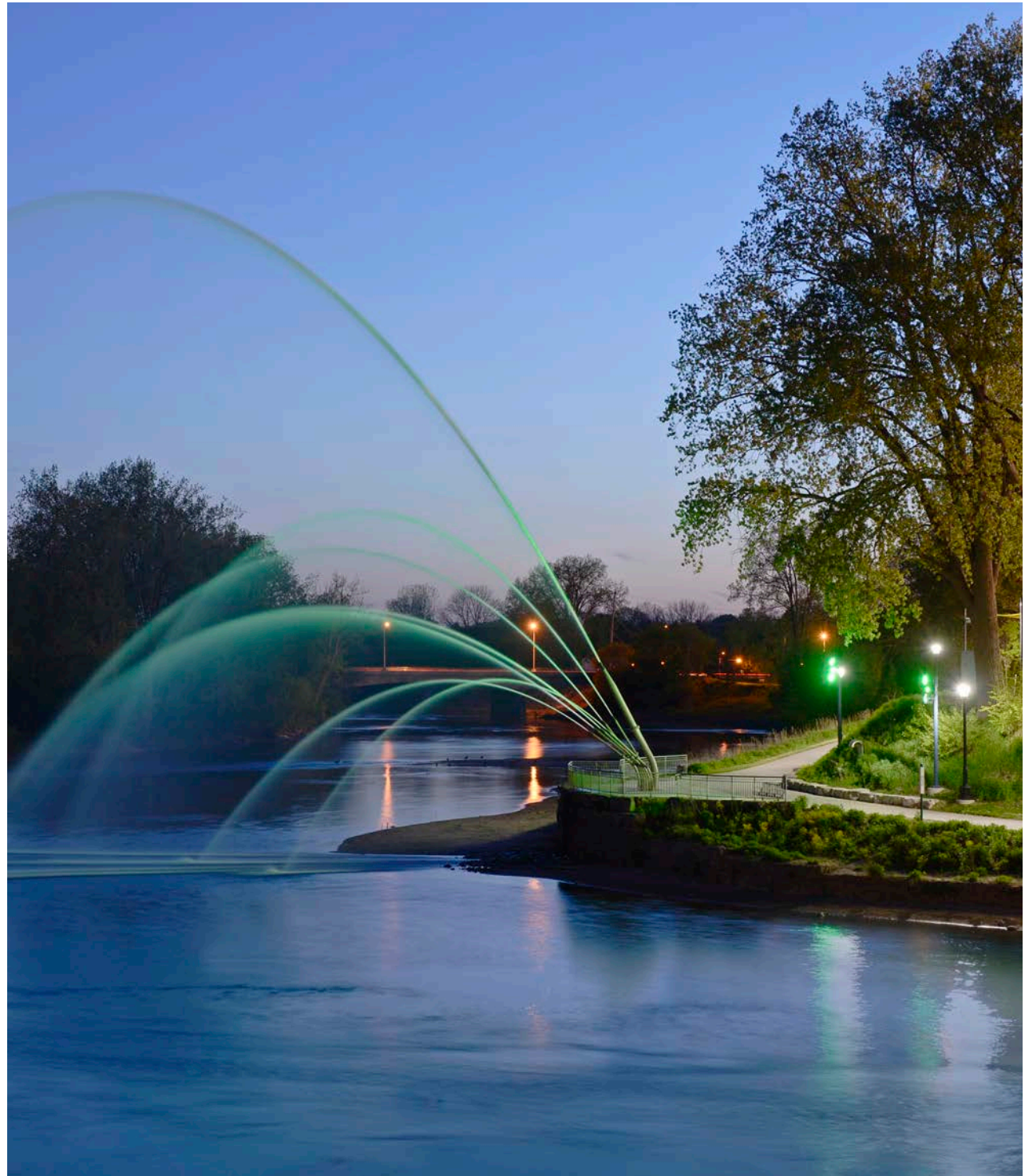



Bike Network

Cycling in the City of London is recognized as playing an important role in achieving a balanced transportation system and promoting an active and healthy lifestyle. Within the Downtown study area, there are a number of cycling network linkages established and/or planned.

1. Development on public land within the Downtown should implement the London Bicycle Master Plan through the establishment of the proposed on and off-road commuter and recreational bicycling network.
2. Complete the Queens Avenue bike lane and consider converting it to a buffered or segregated bike lane.
3. Consider converting the King Street bike lane to a buffered or segregated bike lane.
4. Continue the Colborne Street bike lane north from Dundas Street to Central Ave.
5. Connect the Ridout Street bike lane from Thames Park to the Harris Park Entrance.
6. Convert the shared lane on Dufferin Avenue to a bike lane.
7. Convert the signed bike route on Talbot Street to a bike lane from Dufferin Avenue, north to the University.
8. Convert the signed bike route on Central Avenue to a bike lane.
9. Enhance bicycle connections from Downtown to the Thames Valley Parkway at the Fork of the Thames, Harris Park and the Blackfriars Bridge.
10. The City adopt a set of standard design specification for the bicycle network including buffered and segregated bike lanes.

1.8

Landmarks & Gateways



Forks of the Thames

Riverfront Promenade

The Forks of the Thames is a very important public open space in the Downtown. The spaces surrounding the Forks should be developed to draw people to the river and create a desirable space that will further influence private investment in the area.

Views and access to the Thames River and adjacent public spaces should be protected and enhanced where possible.

The Forks of the Thames should be enhanced on all sides, including the redevelopment of the east side into a year-round regionally significant attraction that will draw visitors for both passive and active recreation. The transformational project envisions an urban promenade with links through an urban park space to the Dundas Place flexible street.

Cross-river Connection

The Cross-river transformational project aims to strengthen the pedestrian connection from the west side of the Thames to the Downtown. Through this project, the Kensington Bridge will be converted into a pedestrian-only crossing.

The design of open spaces on both sides of the river, and the treatment of the Kensington Bridge itself, will need to be coordinated and integrated to ensure an attractive and safe pedestrian environment further links the surrounding areas to the Downtown and public open spaces.

Victoria Park

Victoria Park is an important focal point of the Downtown, particularly because of events that attract a significant number of visitors to the area. The park also serves a way-finding function in the Downtown, allowing pedestrians and vehicular traffic to navigate the surrounding blocks with ease.

Views into and surrounding Victoria Park should be protected and enhanced as much as possible.

Views to Landmark Buildings

Important and historic views to landmark buildings in the Downtown should be protected and enhanced. These include:

- The Armouries Building, as seen from Waterloo and Dundas St.
- The Middlesex County Courthouse – as seen from Dundas and Ridout St.
- The London Life Building as seen from Victoria Park.

- St. Paul's Cathedral, as seen from Fullerton St.
- Eldon House and its garden, as seen from Ridout St.
- One London Place

The design of future landmark buildings in the Downtown should promote a distinctive downtown and skyline.



Gateways

Major entryways into the Downtown should be developed as Gateways, when the opportunity arises. This includes primary vehicular and pedestrian accesses, as well as the train station, which brings a large number of visitors to the city each day for business and leisure.

City Gateway Project

The train station on York Street serves as an important gateway into Downtown for travelers and those entering the city on business. When an opportunity for development occurs around the station, the surrounding area should be enhanced in the following way:

1. A public square be developed in front of the station that allows for passive gathering and active programming.
2. A mid-block connection be established providing direct and convenient access to Dundas Street.
3. Mixed-use development is encouraged in the blocks surrounding the train station to support the activation of the public spaces, and enhance the pedestrian experience.
4. The Richmond Street underpass should be improved to create a safe and enjoyable pedestrian environment as part of this transformational project.

2.0

Built Form &
Site Design



2.0

Introduction

The following Built Form and Site Design guidance applies to planning and construction in the Downtown that is located on private property. This section may also apply to publicly owned buildings or sites which contain buildings, parking lots and structures, and other built forms.

The main goal is to promote the development of buildings and properties that is sensitive to the unique character of Downtown and the individual context of each site. This section of the Downtown Design Manual is to be used by private developers and property owners when preparing applications for Official Plan amendments, Site Plans, Heritage permits and Downtown Incentive programs. It will also be used by City staff in the review of the above development applications and any recommendations regarding them.

Proposals for development within the Downtown should conform with the intent of these guidelines, in addition to the policies of The London Plan, Downtown Heritage Conservation District, Downtown Master Plan, and the regulations set out in the Site Plan Control Bylaw.





2.1

Site Layout

In order to create and maintain a pleasant pedestrian environment in the Downtown, it is desirable to retain the scale and perception of spatial enclosure that currently exists along the majority of streets in the Downtown.

The relationship of buildings to open spaces is also important in Downtown. Two major amenity areas and open spaces, Victoria Park and the Forks of the Thames, form boundaries of the Downtown area.

New development and the reconstruction of facades in the Downtown should aim to establish a high-quality pedestrian oriented environment that is visually interesting, comprehensive, varied and well-connected.

The following guidelines are intended to reinforce the scale and sense of enclosure along Downtown streets and open spaces.

Site Organization

1. In general, buildings within the Downtown should be built at or near the building line to maintain visual continuity and spatial enclosure of the street.
2. Parking should be provided internal to buildings, or in the rear yards of buildings.
3. Where parking is to be included in the ground level of buildings, active uses should be provided fronting the street wrapping the parking located at the rear of the building. This is outlined in more detail in the *Parking* section of this manual.
4. Gaps in the streetwall greater than 10m are strongly discouraged. Building mass should be distributed to fill in the streetwall as much as possible.

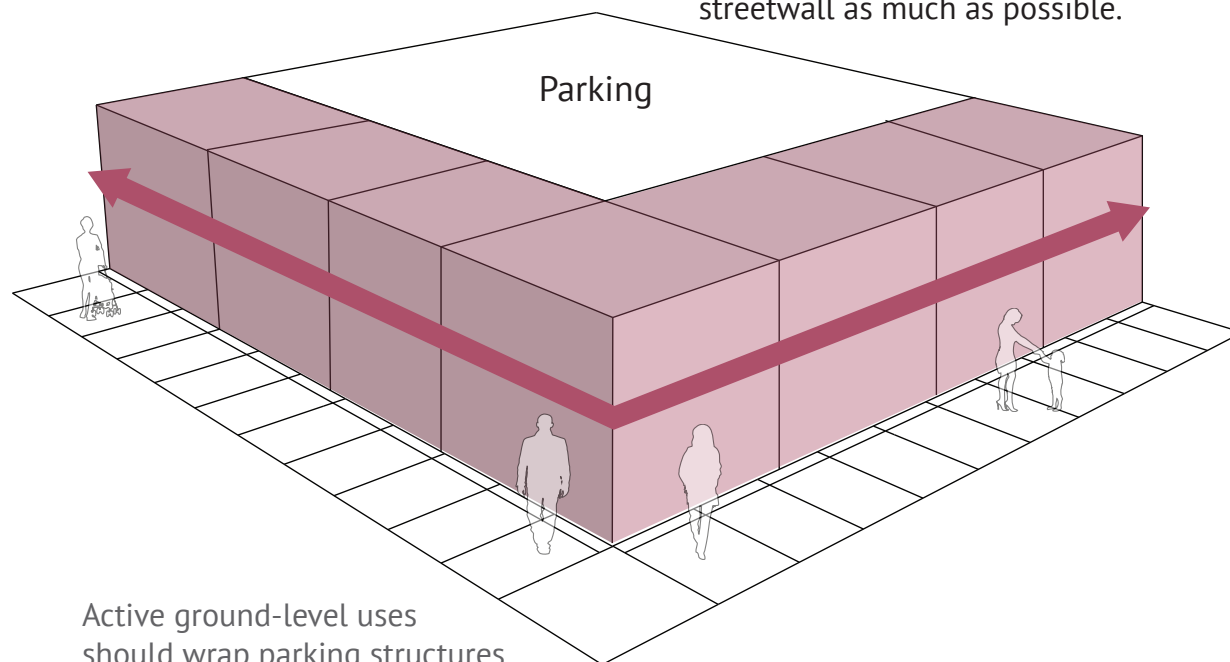

Active ground-level uses should wrap parking structures.

5. Measures should be taken to minimize the appearance of large openings, such as:
- Enclosing openings within the podium of buildings, or creating false facades at the second storey to enclose the gaps.
 - Incorporating landscape walls of the same building materials along the street edge and in line with the buildings.

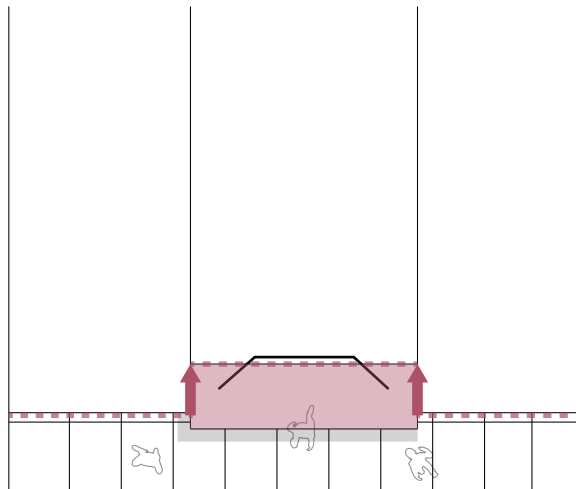

Ground-level setback to provide weather protection.

Massing

1. Corner sites should have the building massing located at the corner.
2. In the case of tall buildings on corner sites, the tower portion of the building should be located on the corner, whereas a rectangular base may continue to the middle of the block.
3. In the case of large corner properties, the building should be located closer to the higher order street where it cannot complete both streetwalls.

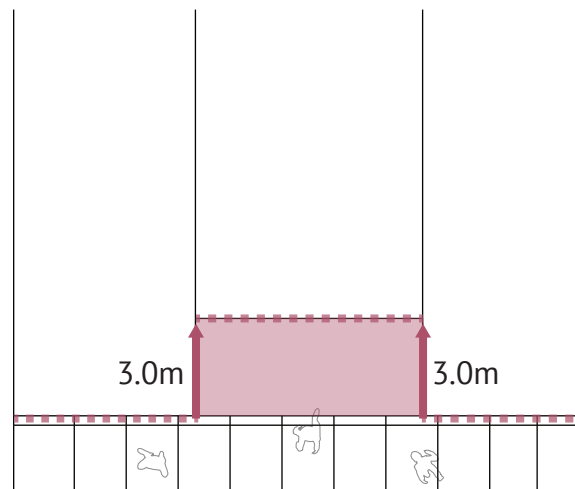

Ground-level setbacks should not exceed 3m

Building Setbacks

1. Minor ground level setbacks may be acceptable along individual building facades in order to provide covered pedestrian entrances, covered arcades for weather protection, and to establish individual building identity.
2. Where new structures abut existing buildings, the locations of ground level building walls should enhance the continuity of the sidewalk and pedestrian movement patterns, and avoid awkward discontinuities in the sidewalk.
3. Minor setbacks at grade should not exceed 3m in depth to maintain street continuity and avoid “non-defensible” recesses.
4. Spaces greater than 3m in depth and width are considered to be plazas and are covered in the Public Spaces section in *Streetscape Design*.

The following guidelines describing the preferred visual character of building facades at the ground level, and the preferred built form for various types of structures.

2.2

Built Form

Building Height Guidelines

1. With the exception of development along York St, new development along streets within the Downtown is encouraged to retain a three to four story height at the building line.
2. Where new buildings abut existing structures at the building line, the new structure should align with the adjacent building cornice lines, or provides a clearly visible and readily apparent offset in height so as to maintain the visual integrity of the existing structure.

The construction of a variety of dwellings is encouraged within the Downtown to accommodate various lifestyles. Dwellings should consist of both low and high-rise built form, depending on context and location.

Orientation

For buildings that face major open spaces along the Thames River and Victoria Park:

1. The first three to five stories should be built as a continuous streetwall. This may be accomplished using a solid building mass, a continuous arcade treatment or covered walkway design. The intent is to provide spatial enclosure for these important spaces.
2. The portion(s) of the building above the first three to five stories should be oriented with their long axis perpendicular to the open space to maximize view opportunities toward these spaces. Orientation maximizing views should take precedence over orientation to maximize solar penetration.
3. For buildings that front onto east-west streets, portions above the first three to five stories should be designed with the long axis of the building oriented in a north-south direction to maximize opportunities for sunlight penetration into the street-level pedestrian environment.

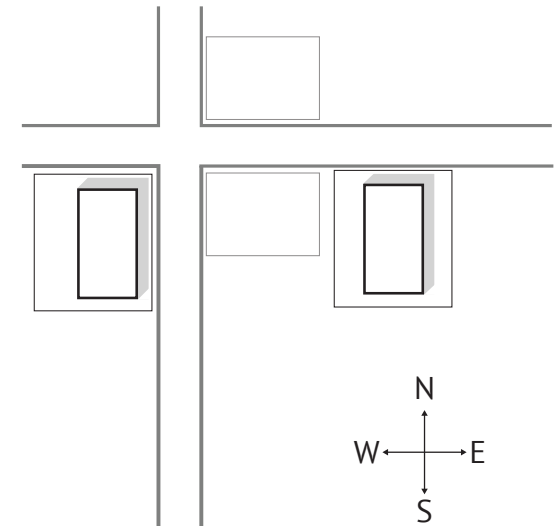

Towers of buildings oriented North-South

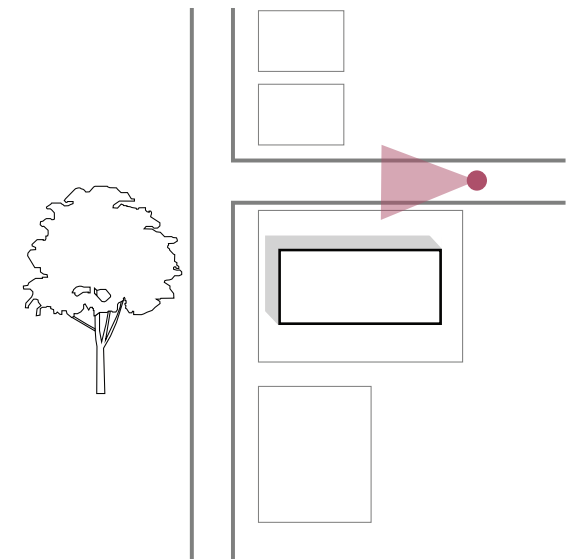

Towers allowing views into open space



2.3

Tall Buildings

Definition

A tall building is defined as a building with a height that is greater than the width of the adjacent street right-of-way or the wider of two streets if located at an intersection.

Design of tall buildings in the Downtown may differ in response to the street type and building use. A tall building is divided into the following three parts, which should be carefully integrated into the form and design of the building.

While architectural creativity and innovation may result in unique building designs that do not following the below building parts, it is recognized that the majority of tall buildings in Downtown will generally have a base, middle and top.

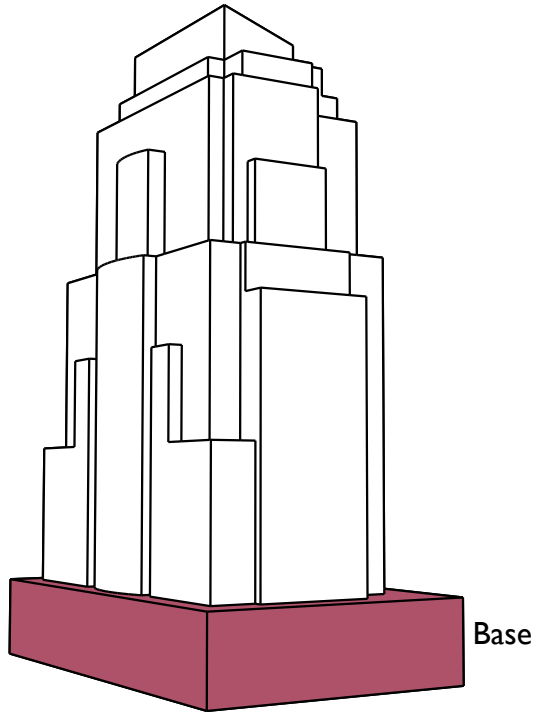

Base: The base of the building consists of the lower stories of a tall building.

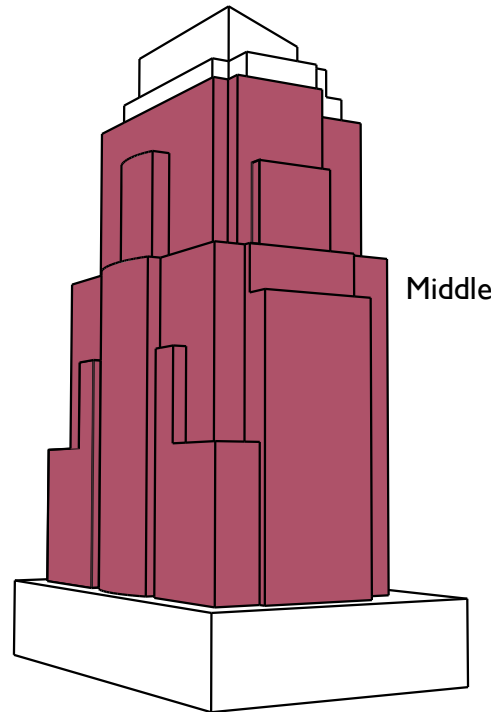

Middle: The middle portion of the building consists of all the stories above the base and below the top.

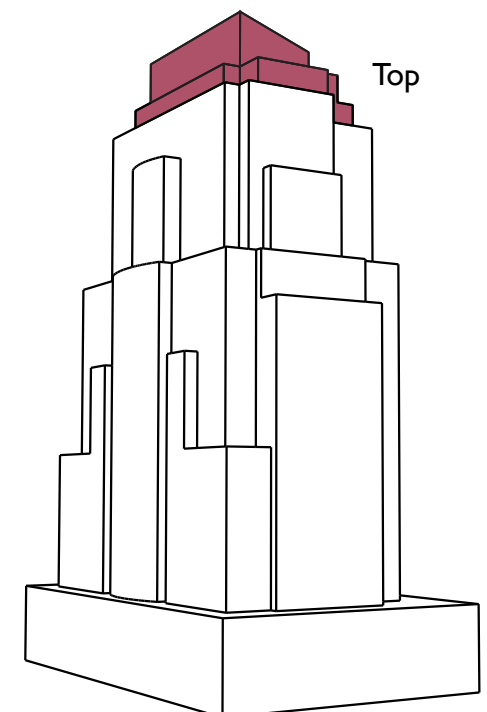

Top: The top of the tall buildings include upper floors and roof-top mechanical equipment, signage and amenity space.

Building Base

The role of the base is to frame the public realm, articulate entrances, create an attractive and animated public realm, and provide a high-quality and safe pedestrian experience. The base of the building defines and supports adjacent streets, parks and open space. It integrates with the existing built form on the street, helps to transition building heights and minimizes the impact of parking.

Scale and Height

Design the base to integrate seamlessly within existing building heights and scale.

1. Where there is an existing context of street wall buildings with consistent height, align the new base building with the height of the street wall.
2. Where a consistent street wall height context is not present, provide a minimum base building height between three to five stories.
3. Base height greater than 3 stories may be appropriate provided that a stepback of at least 3m is incorporated and provided that the total height does not exceed 100% of the adjacent street right-of-way.

4. On corner lots, the height and form of the base should be varied to address the height and form of both adjacent streetwalls.
5. Where neighbouring sites are lower in scale and not anticipated to change, the base should transition in height down to the lower scale. The portion of the base immediately adjacent to the neighbouring building should match the lower scale.
6. The scale and height of the base should respect the proportion of adjacent streets, parks and public or private open space.

Active Street Frontage

Include active, grade-related uses in the base to promote a safe and animated public realm.

1. On streets with a mixed-use or commercial character, include a series of ground floor commercial and retail uses in the base
2. On streets with an exclusively residential character, include grade-related residential units with front entrances and windows into living spaces in the base.
3. On streets where an active street frontage character is not yet established, design the base to provide for flexibility to accommodate any future transitions.

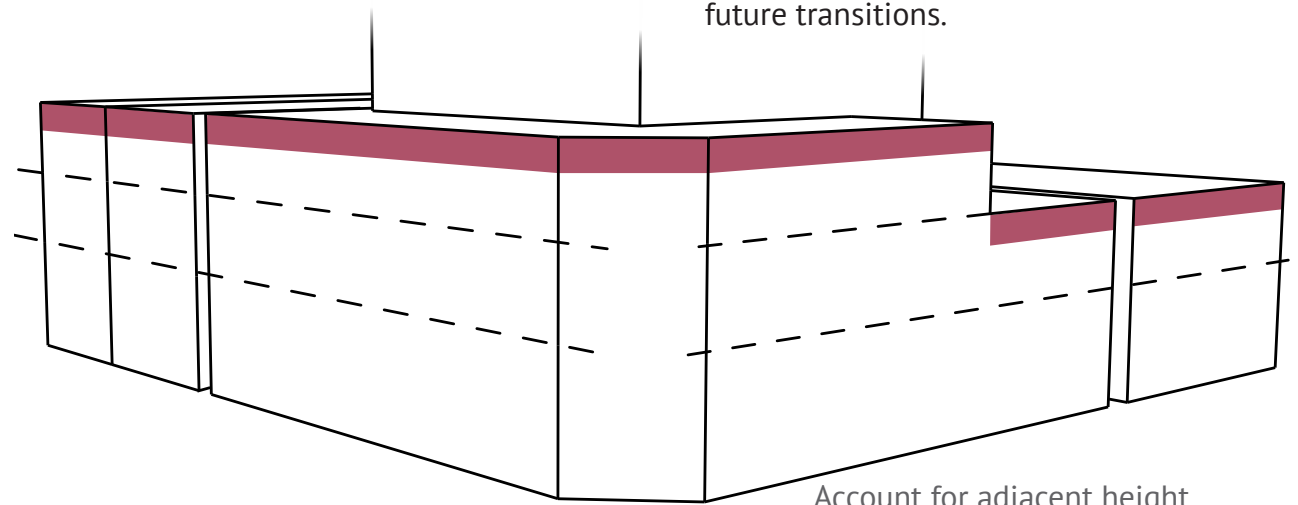

Account for adjacent height differences within the building base.

First Floor Height

First floor height should be a minimum of 4.5m high.

1. Maintain a relationship between first floor heights of neighbouring residential buildings and the first floor height of the base.

Facade Articulation and Transparency

Articulate the base with high quality materials and design elements that fit with the character of neighbouring buildings and contribute to the public realm.

1. The base facade should be articulated with design elements, such as cornice lines, window bays, entrances, canopies, high-quality building materials, and fenestration, in an appropriate pattern, scale, and proportion that relates to neighbouring buildings and enhances the pedestrian realm.

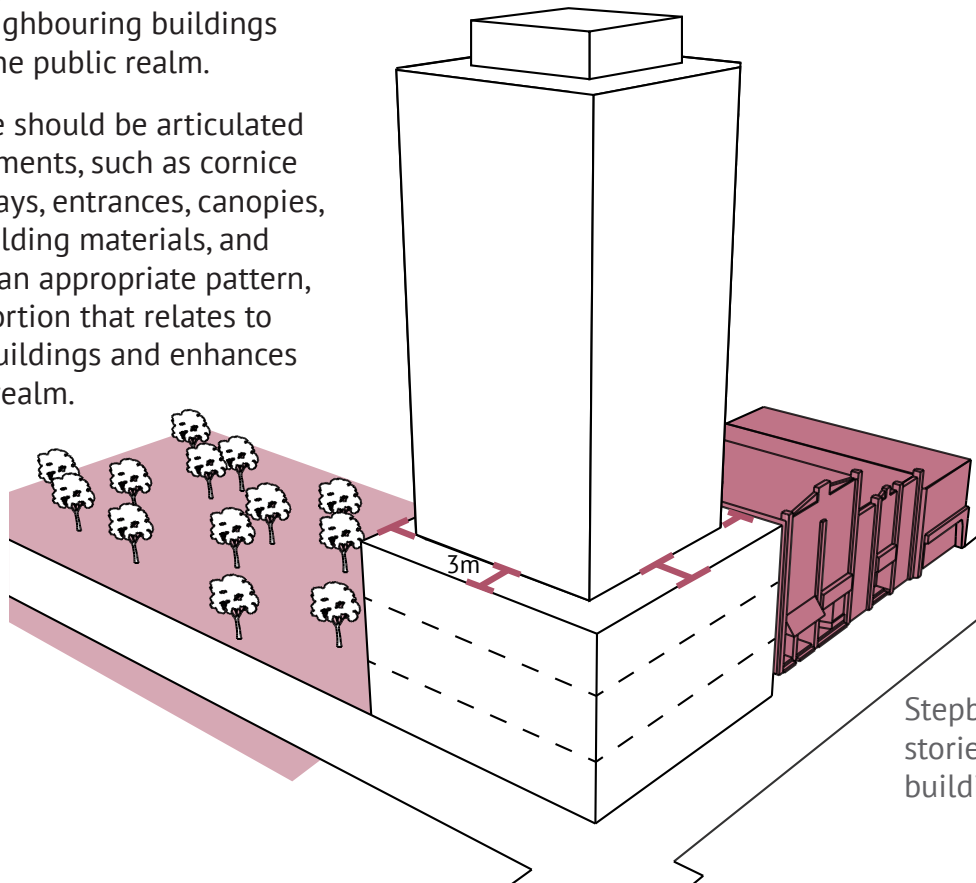

Stepback building facades above 3-4 stories when adjacent to existing buildings, the street or public open spaces

Building Middle

The role of the middle is to provide the vertical extension of the building between the base and the top. Location, scale, floor plate size, orientation and separation distances of the middle have an impact on sky views, privacy, wind, sunlight and shadows. The design and placement of the middle should mitigate these impacts on surrounding streets, open spaces and neighbouring buildings.

Floor Plate

The middle floor plate should be limited to 800m² or less per floor.

1. The tower floor plate should be located to minimize adverse shadow and sky view impacts, allowing for maximized natural light that visually reduces the overall scale of the building.

Placement

The middle of buildings should be setback from streets, parks, open space, and neighbouring properties to reduce its visual and physical impacts. The base should be the primary defining element for the site.

1. Step back the middle, including balconies, 3m or greater from the edge of the base, along all street, park, and open space frontages
2. Middle setbacks greater than 3m are encouraged, especially in site that contain or are adjacent to heritage properties.

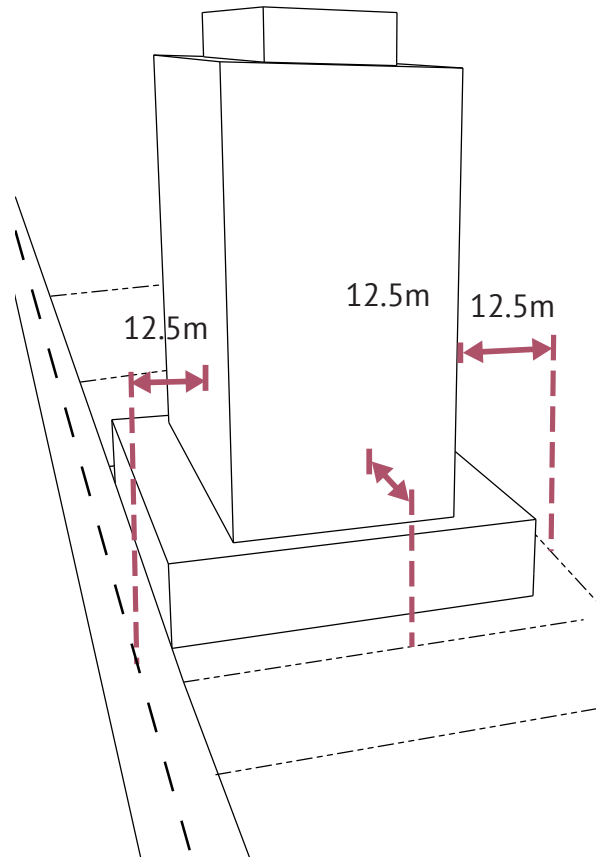

Middle portions of the building should be offset 12.5m from street centerlines and property lines to split the 25m separation distance for buildings on adjacent properties.

Separation Distances

1. Provide separation distance between towers on the same site of 25m or greater.
2. Setback tall building middles 12.5m or greater from the side and rear property lines or street centreline.
3. Where taller buildings or larger middle floor plates are proposed, provide greater setbacks and separation distances in proportion to building size and height.
4. Apply creative building designs, such as offset towers/views, non-parallel walls, tapering or curved tower forms where possible, to increase actual or perceived tower separation distances.
5. On small sites, minimum middle setback and stepbacks shall be applied to determine the resultant floor plate size and feasibility of the site size to accommodate a tall building.

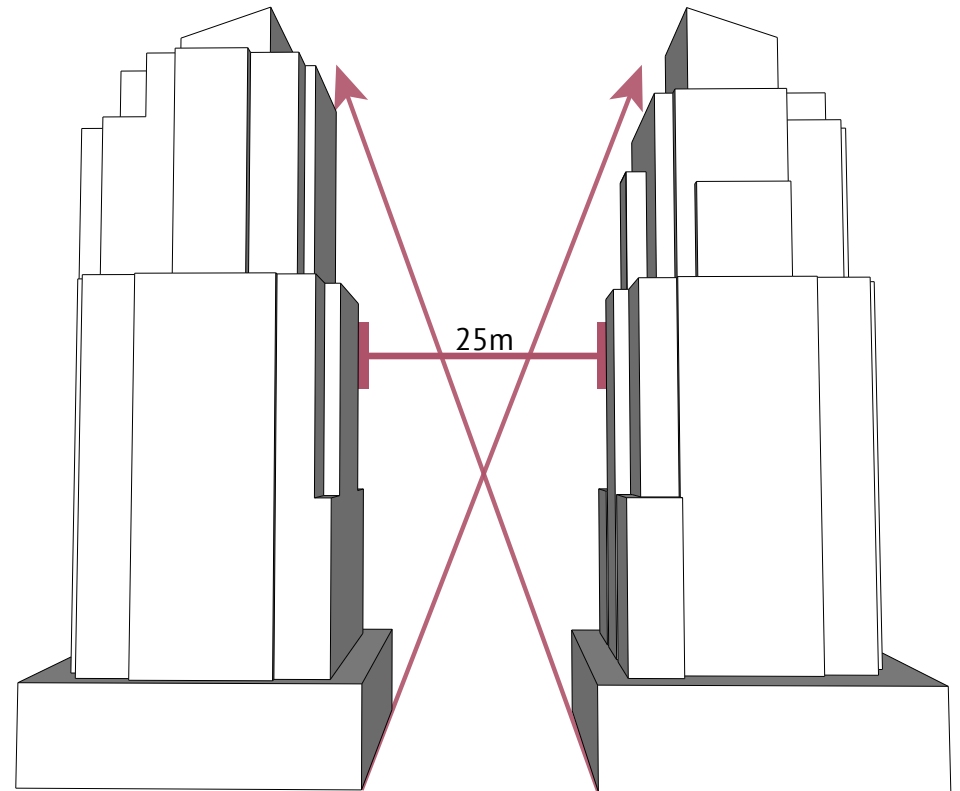

Minimum tower separation of 25m

Orientation and Articulation

Orient the middle of buildings to improve building energy performance, natural ventilation, and daylighting, provided that access to sky view is maintained and that wind and shadow impacts are minimized.

1. Variation in the design and articulation of each façade is encouraged to provide visual interest.
2. When multiple towers are proposed, vary the tower heights to create visual interest, mitigate wind and improve access to sunlight and sky.
3. Articulation of the middle with high-quality materials and finishes is encouraged to promote attractive building facades.

Materials

1. Non-reflective materials should be chosen that prevent bird strikes on tall buildings.

Building Top

The top of a tall building contains the upper floors and roof-top mechanical or telecommunications equipment, signage, and amenity space. This area should be designed to create an integrated and attractive finish to the tall building.

Tower Top Design

Design the top of tall buildings to contribute to the quality and character of the city skyline

1. Integrate roof-top mechanical or telecommunications equipment, signage, and amenity space, where appropriate, into the design and massing of the upper floors of the tall building.

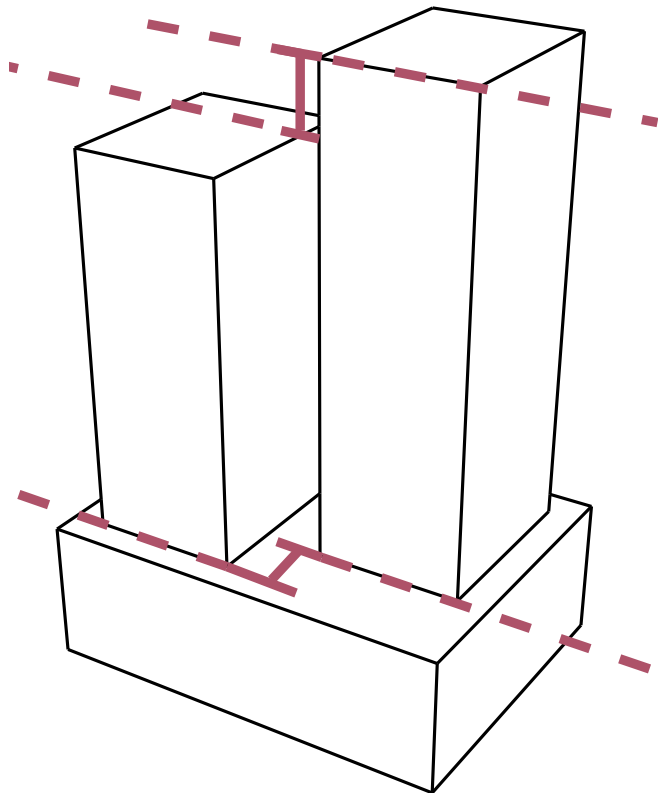

Offset heights & setbacks for multiple towers



2.4

Architectural Details

Architectural Treatment

The following guidelines are intended to outline the preferred treatment for certain architectural elements on building facades. As a general rule, buildings should appropriately relate to one another and positively contribute to the existing pattern of Downtown development.

Complementary colours, textures, cornice lines, window treatment, scale and massing, are important elements of the overall urban design of Downtown. This would not prescribe that every building look like its neighbour, but rather, that it complement and not overwhelm its neighbour.

The following guidelines shall apply to new and redevelopment projects:

1. Where possible, existing facades with architectural or historical merit should be retained and incorporated into new development.
2. The removal of non-historic or inappropriate facade materials on existing structures is encouraged. Existing quality materials should be preserved and uncovered wherever possible, and new materials chosen to complement the existing development.

3. New development should continue the horizontal and vertical proportions of surrounding existing buildings.
4. Development should incorporate 25% to 60% glazing on upper levels, to retain the proportions characteristic of the existing structures in Downtown.
5. Major horizontal facade elements such as cornice lines, floor elevations, and trim bands should be continued through new development.

6. Creative and innovative design is encouraged in Downtown. The use of signature elements such as articulated roof pediments, exterior lighting, etc. is encouraged, particularly at locations identified as important Downtown gateways.
7. Where possible new and retrofit buildings should look to achieve LEEDs gold rating. To assist with greening the downtown and reducing the heat island effect opportunities to use green roof technologies should also be examined.

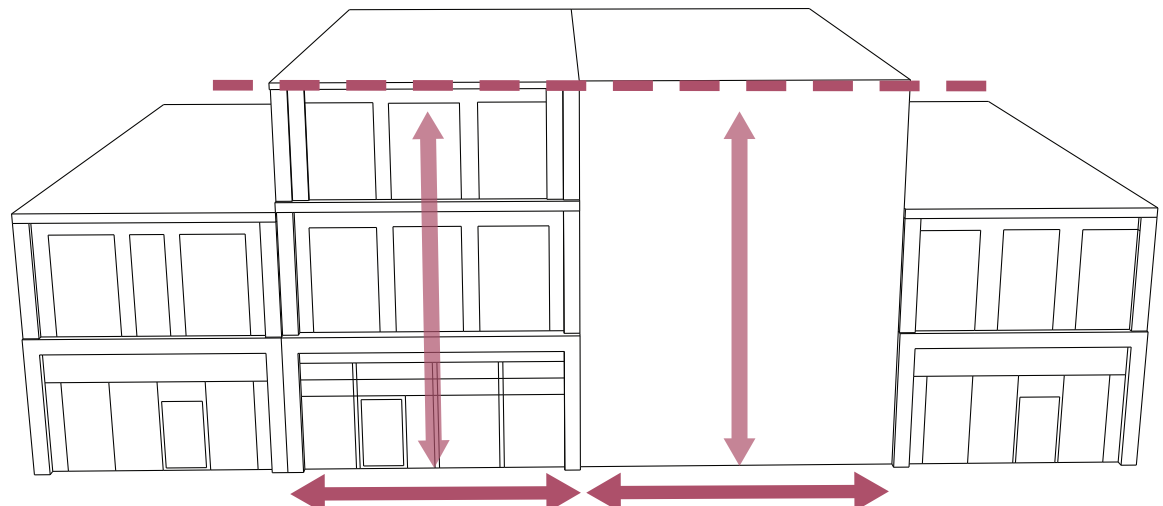

Continue horizontal and vertical proportions

Building Materials

The Heritage Conservation District Plan outlines building materials that are considered to be appropriate and inappropriate in Downtown, based on historic use. The selection of building materials should consider the following:

1. The most common building materials in Downtown include cut stone, brick, masonry, and concrete, with many new buildings incorporating glass curtain wall. Each of these materials is considered to be appropriate.
2. Natural materials should be used in lieu of synthetic simulations or substitutes where possible. When this is not practicable, alternative materials should be designed and utilized to produce attractive architectural treatments.
3. The restoration of original building facades and materials through City and BIA Incentive Programs is encouraged.
4. Where new construction abuts existing structures, distinctively different materials should be used in the new construction. If similar materials are proposed, design details should be used at the intersection of the new and existing materials to retain the architectural integrity of the existing structure.



25% to 60% glazing on upper stories

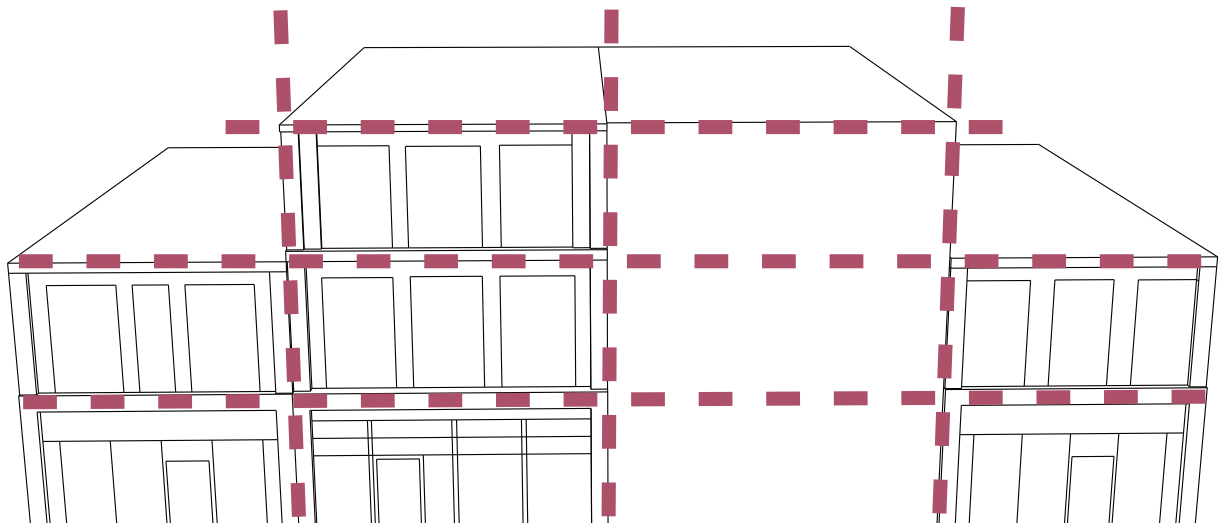

Continue roof, cornice and trim lines

Storefronts

The pattern of windows and building openings is an important element of the visual character and functional vitality of the street. Much of Downtown London is characterized by the storefront layout that was typical of late 19th and early 20th century commercial architecture.

“Standard” elements of the storefront included tall windows and glass doors, a recessed opening flanked by display windows, and a low “kick-plate” beneath the storefront windows. Awnings were often incorporated to provide pedestrian weather protection. Business signage was typically located immediately above the storefront in a specifically designed sign panel.

The following guidelines are intended to encourage development that is sympathetic to the existing development pattern in the Downtown:

1. Generally, the existing condition along the primary retail streets is a series of continuous storefronts. Continuous expanses of blank wall, greater than 3m wide, at the street level are discouraged.
2. 40 to 50% of building facades at the street level should consist of vision glass or entrances.
3. Multiple openings and entrances along multi-tenant building facades are encouraged over single, shared entrances to maintain a small scale and promote individual identity and character.
4. The Site Plan Control By-Law requires planting material to be placed every 3m along blank building walls and enclosures. This provision should not be applied to blank wall conditions in Downtown.



40% to 50% glazing on ground floor facades

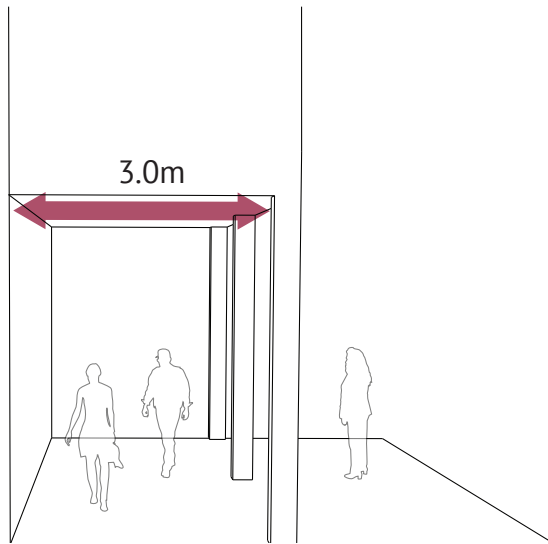

Minimum horizontal depth for arcades

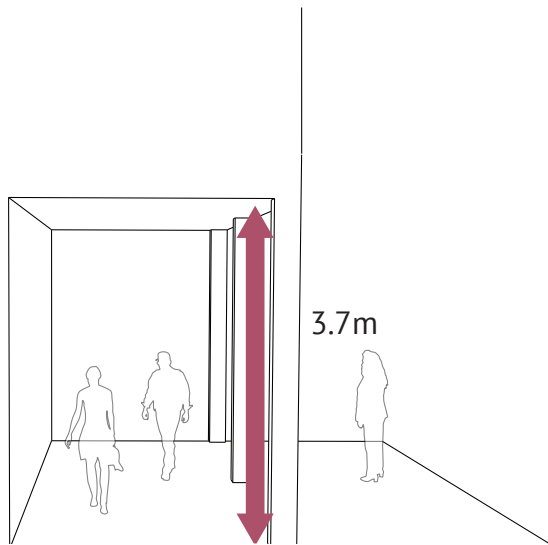

Minimum vertical clearance for arcades

Arcades

Arcades are considered to be desirable street-level features of Downtown buildings. They provide shelter for pedestrians, and add to the visual interest of the street. Building cantilevers (not supported by columns) above the ground floor are considered to be variations of arcades.

The following guidelines apply to any new development which includes an arcade feature:

1. Arcades should provide a minimum of 3m between the face of the building and the face of the supporting vertical elements along the sidewalk.
2. Arcades should have a minimum vertical clearance of 3.7m between the sidewalk surface and the underside of the arcade ceiling.
3. Arcades should not be permitted to extend into the public right-of-way. Special exceptions may apply in extraordinary circumstances where property and roadway configuration permits, and where significant space would be added to the public sidewalk area.
4. For uses abutting arcades the Plazas guidelines of the *Public Realm Spaces* section should be referenced.

Relationship of Arcades to the Sidewalk

1. In general, arcades should be at the same grade as the adjacent sidewalk areas in order to extend the public sidewalk environment.
2. Grade changes of 0.3m or less should be avoided due to safety considerations.
3. Arcades should be open to the adjacent sidewalk areas. Cutting off the arcade space from the sidewalk area with planters, railings, etc. is discouraged.
4. Arcades should provide for continuity of pedestrian movement between the covered space and the adjacent sidewalk areas. Dead end cul-de-sac type layouts are strongly discouraged.

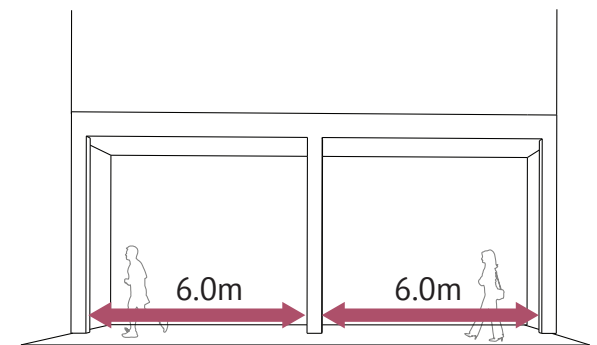

Vertical elements placed max. 6m apart

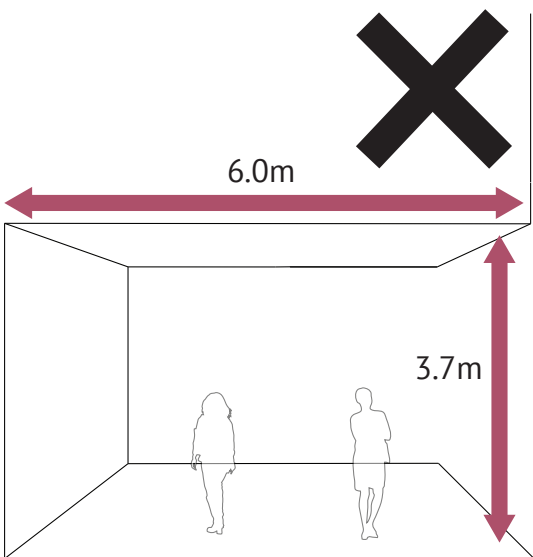
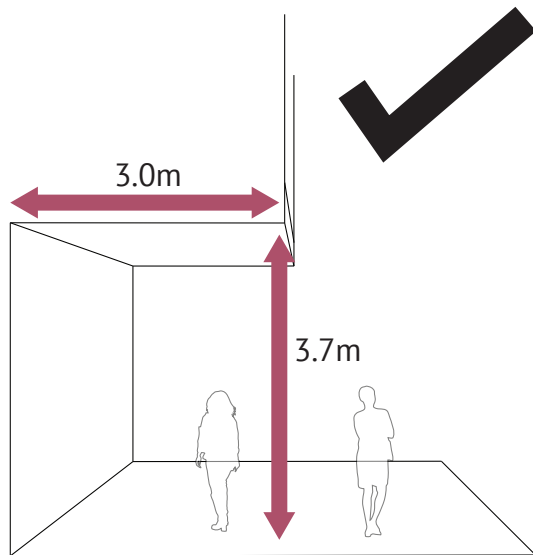

Arcade depth should not exceed its height

Arcade Architectural Treatment

1. To maintain the small scale street-level environment that exists in the Downtown, the spacing of the vertical elements along the sidewalk edge should not exceed 6m, which approximates the width of the storefronts in existing older Downtown structures.
2. Arcades should be designed as recesses into the building facade, as opposed to outward extensions from the main building facade, to maintain the characteristic of older buildings.
3. In general, arcade-type structures are preferred, over a cantilever design in order to provide weather protection and continuity of the street facade lines.

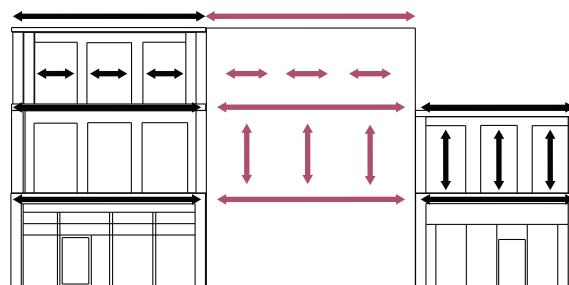

Maintain rhythm of cornice lines, floor elevations and glazing

4. The depth of the space should not exceed the opening height, in cantilevered designs.
5. The floor surface of arcades should be the same paving materials as the adjacent sidewalk, to visually extend the sidewalk area to the face of the building beneath the arcade.
6. If materials other than those in the adjacent sidewalk areas are to be used, they should be distinctively different than those used in the sidewalk areas in order to maintain the design integrity of the paving used on the public sidewalk.

Upper Floors

Upper storey windows, cornice lines and roof pitches should be complementary to the existing buildings surrounding the property. Where possible, these elements should line up with neighbouring buildings. Where it is not possible to align windows, cornices and horizontal details, care should be taken to ensure these elements are significantly offset.

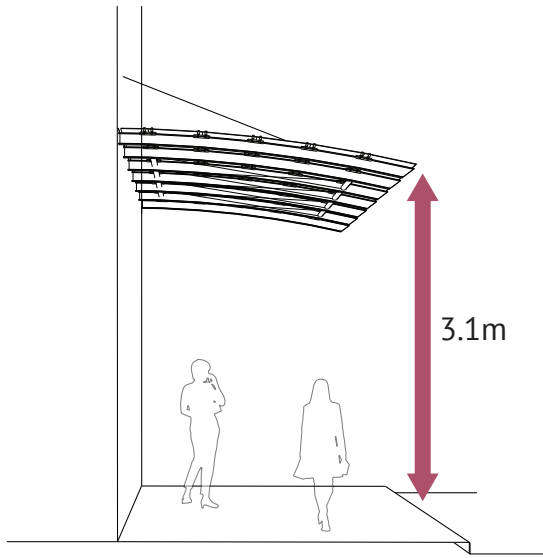

Minimum vertical clearance

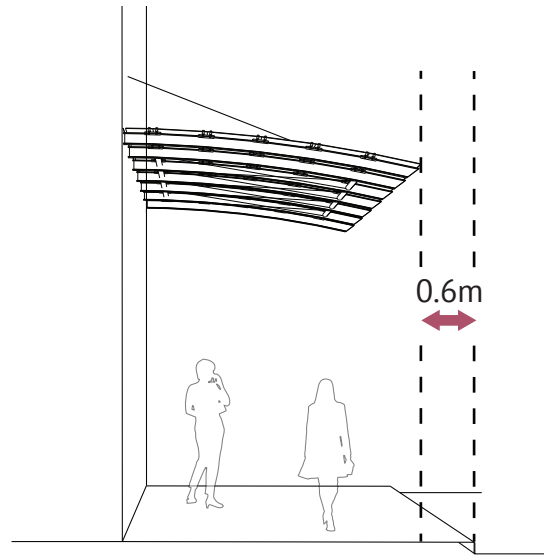

Setback awnings 0.6m from curbline

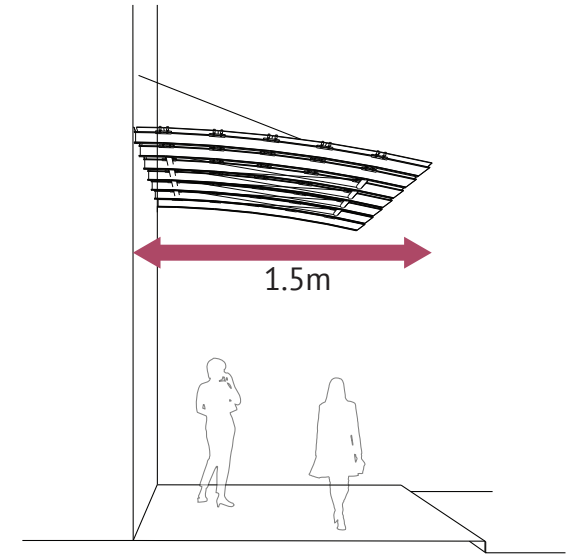

Minimum depth from building face

Awnings and Canopies

Awnings or canopies are roof-like covering fixed to a building and extending over the sidewalk. Awnings are generally made of fabric, while canopies are hard and structural.

Awnings and canopies are regulated by the sign and canopy by-law and require a licensing agreement as well as a permit.

1. In the Downtown, awnings and canopies are appropriate, especially along retail shopping streets. They provide colour, enhance the scale of building facades, and contribute to a distinctive street identity.

2. Awnings and canopies provide a distinctive visual quality to the street, but must be coordinated to prevent visual clutter.
3. Awnings should fit the proportions of the building facade to which they are attached and will extend into the right-of-way on structures built at the building line.

Dimensional Criteria

Awnings and canopies should meet the following dimensional criteria:

1. A minimum clearance height above the sidewalk of 3.1m.
2. A minimum clearance of 0.6m between the curb line and the outside edge of the awning.

3. A minimum depth of 1.5m to provide pedestrian weather protection. However, this dimension must not intrude into tree canopies located in the sidewalk area, or into the 0.6m distance from the curb line.
4. The vertical and horizontal dimensions of awnings and canopies on adjacent frontages should be coordinated. However, they must meet the minimum dimensional criteria listed above.

Where possible, adjacent structures should match the vertical height and vertical clearance of the awnings above the sidewalk. Where it is not possible, a distinctly visible offset is preferred.

Aesthetic Criteria

Awnings and canopies should meet the following aesthetic criteria:

1. Awnings should not be used to cover attractive architectural details on existing structures.
2. Signs and advertising on canopies and awnings is subject to the applicable sign guidelines.
3. Fabric awnings are preferred. Plastic or metal awnings are strongly discouraged.
4. Solid colour awnings are preferred. However, vertical stripes have an historic precedent in Downtown. If vertical stripes are used, only two colours (exclusive of colours for lettering) should be used. It is preferred that these stripes be 0.4m in width, or be very narrow with a wide horizontal separation.
5. Awnings designed for internal illumination of the entire awning surface are discouraged.
6. Awnings designed for internal illumination of a sign panel on the valance of the awning are acceptable.

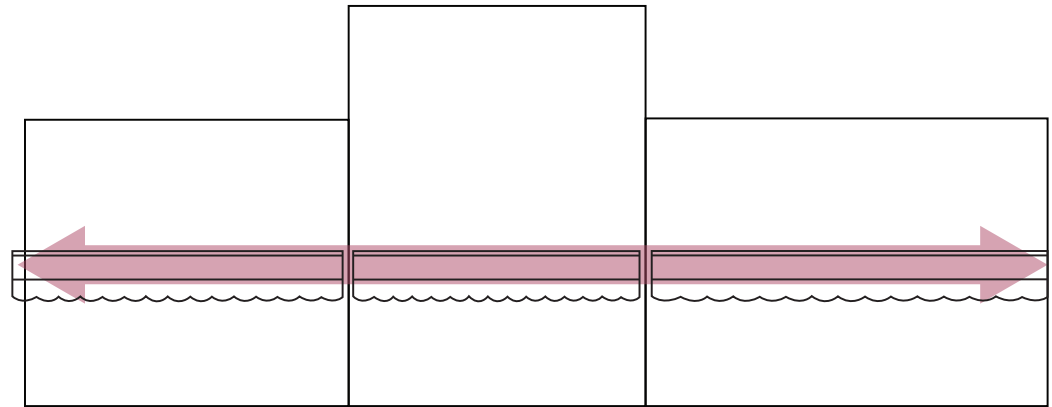

Maintain canopy and awning heights along the streetline

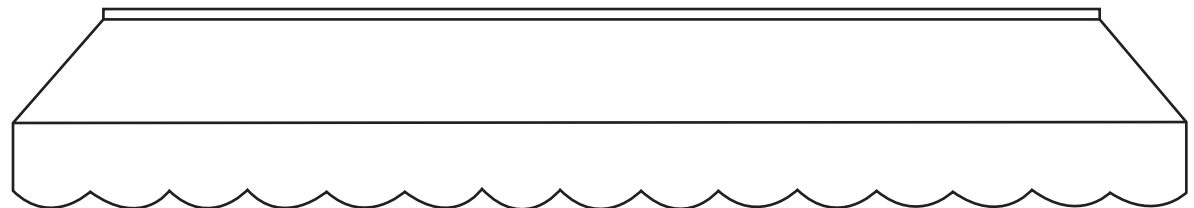

Preference for solid coloured awnings

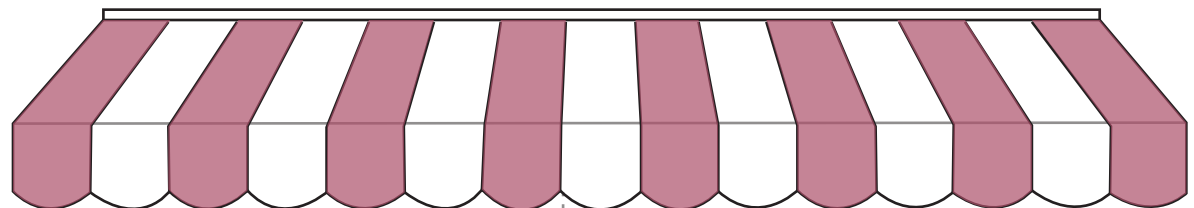

Two-colour awnings with 0.4m wide stripes

Signage

These guidelines are meant to outline general principles for building signage that are sympathetic to the needs of the property owner, while encouraging the improvement of the visual quality of Downtown.

The older retail buildings along the major streets in Downtown provide a historic precedent for the location of signs. The prevailing sign type on 19th century buildings was the fascia sign. This type of sign was horizontal, and located in the fascia, the flat band between the display windows and the frieze and cornice that defined the ground floor of the building.

These signs traditionally were made of wood, with the store name either painted on the sign board, or channeled letters painted in a contrasting colour. Other fascia signs include individual carved letters attached directly to the building face.

Other sign types include projecting signs that hang over the sidewalk perpendicular to the building face, wall signs mounted parallel to the building face, and movable, sandwich-board type signs often used by restaurants. All of these sign types are considered appropriate in Downtown, if used properly.

Types of Signage

1. Billboard signage, both freestanding or mounted on buildings, are prohibited in the Downtown. Free-standing, pole mounted signs and movable, temporary flashing signs (except highway or work crew signs) are also prohibited.
2. Projecting signs are strongly discouraged above the ground level. Signs above the ground level should be placed on and parallel to the facade.
3. Small projecting signs perpendicular to the sidewalk are appropriate on the ground floor level. These signs are considered secondary to the main signage, and are oriented towards pedestrians on the sidewalk, adjacent to the storefront. Because of their function, it is encouraged that these signs not exceed 0.37m^2 (4ft^2) of surface area.
4. Small projecting signs may be underhung from awning structures or attached to the facade of the building. The bottom of the sign should be a minimum of 2.4 m (8ft) above the sidewalk surface.
5. Advertising signage on transit shelters, benches, and other furnishings should be designed to visually complement, rather than “overwhelm,” the structure to which they are attached.

6. Movable, ‘sandwich-board’ signs are acceptable, provided they do not obstruct pedestrian movement along the sidewalk. These signs should be placed on private property where possible. They may be permitted on the curb-side of sidewalks where space is available. Signs placed in the public right-of-way are to be removed at the end of the day.

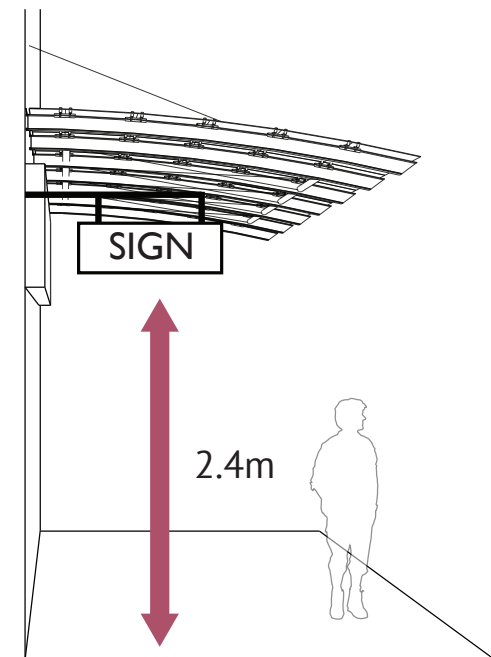

Projecting signs underhung from canopies with 2.4m minimum clearance height

Location of Signage

1. It is preferred that the primary sign used to identify a business be located immediately above the storefront, or above the awning if one exists.
2. On existing buildings, owners are encouraged to place signage within the architectural framework of the ground level facade. It is preferred that signage not cover or otherwise obscure attractive architectural details.
3. Signage may be incorporated into awning or canopy valences.
4. Signage on the glass of store fronts is acceptable, but should be designed so as to not obscure interior displays.
5. Signage on boards or cards mounted to the inside surface of storefront windows is strongly discouraged.

Lettering Size

1. In general, the streets in Downtown are oriented toward pedestrian shopping activities and related uses. The street widths do not require large lettering in order to be visible from the opposite sidewalk.
2. The lettering for primary business signs should not exceed 0.6m (2ft) in height.
3. Lettering on awning valences and projecting signs should not exceed 0.2 m (8inches) in height.
4. Lettering on glass storefronts should not exceed 0.3m (12 inches) in height.
5. In general, merchants are encouraged to use graphic symbols and “logos”, rather than excessive numbers of words, to achieve a distinctive identity.

Sign Illumination and Materials

1. Internally illuminated box-type signs are generally discouraged.
2. Reverse-channel letters with internal, concealed illumination, or externally illuminated signs with concealed light sources are preferred.
3. Plastic sign lettering is discouraged. Painted wood, brass and cast aluminum or other metal are considered to be preferred materials for sign lettering.



2.5

Interior Spaces

Interior Pedestrian Walkways

Interior ground-level pedestrian spaces and walkways are considered to be desirable additions to the overall pedestrian environment in Downtown.

The location and design of interior ground level pedestrian spaces should be subject to the following design guidelines:

1. Interior pedestrian spaces are encouraged to provide connections to existing or planned activity centres, such as large offices and shopping areas.
2. Interior pedestrian spaces are encouraged to provide linkages between parking facilities and existing or planned activity centres.
3. Where interior walkways are clearly intended for public use, their interior design should reflect this purpose.
 - Interior paths should be clearly marked for orientation to the outside sidewalks, streets and areas through way-finding signage.
 - Blind twists and turns should be avoided in interior pedestrian routes.
4. For visual surveillance and security, ground level uses adjacent to interior spaces should have a high proportion of a clear glass in the partition between these activities and the interior walkways. Blank wall surfaces should be avoided.
5. Ground level activities adjacent to interior walkways should have their main entrance oriented to the exterior sidewalk. Pedestrian access to these activities solely from the interior is strongly discouraged.
6. Interior pedestrian walkways that are to remain open in the evenings, when other activities in the building may be closed, should incorporate security and lighting to maintain a safe pedestrian environment.
7. Courtyards intended for public use are encouraged to have clear visual linkages to the public sidewalk. Appropriate way-finding signage should be provided indicating entrances to and exits from such spaces.

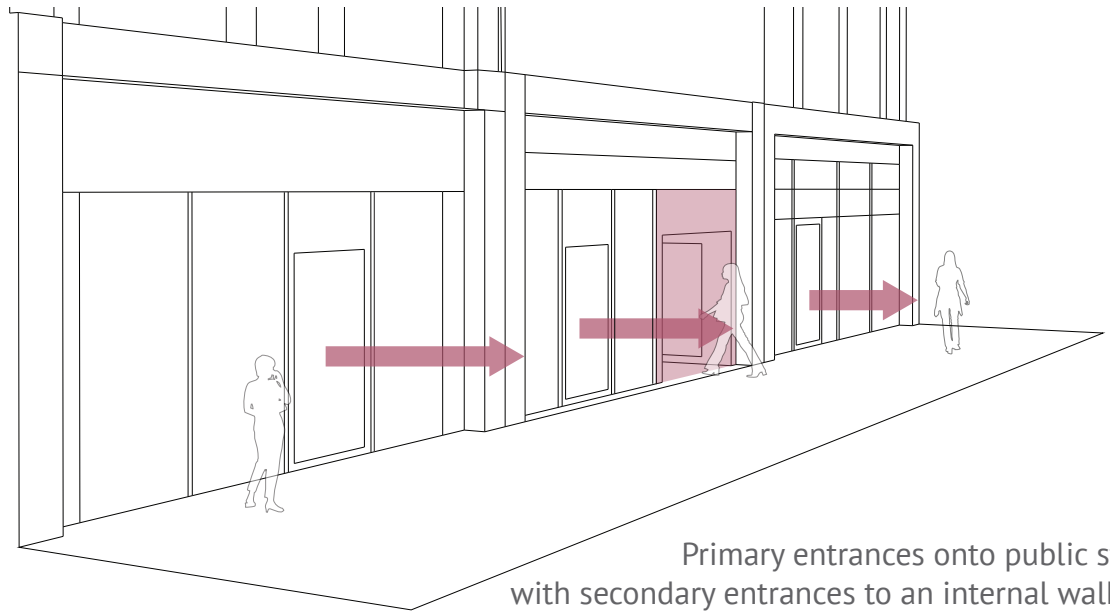

Large Converted Buildings

Large structures converted into various smaller shops should incorporate design devices that visually present the various interior shops or uses to the exterior sidewalk area. Combined exterior signage panels are one common method used to identify interior activities. Display of graphic symbols, or of individual shop “logos” is another technique that might be employed.

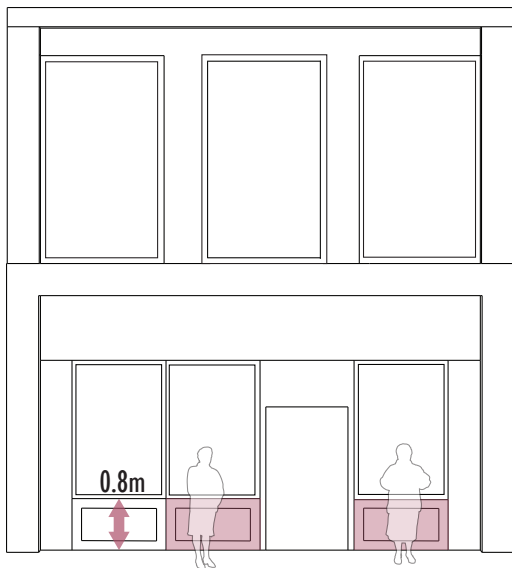

Maximum wall panel height under windows

The following guidelines shall apply to large converted buildings, and other shopping mall development:

1. Reflective or dark tinted glass at the street level is discouraged. Glazing that allows for views into buildings is preferred. Window elements at the street level such as framing and mullions should minimize obstructions of views into display windows.
2. Building entrances should not be recessed more than necessary to provide space for the door to open within going into the right-of-way.
3. Solid wall panels beneath storefront display windows should be no more than 0.8m above the sidewalk level, to maintain the open character of traditional storefront design.
4. New buildings should be designed and constructed to be flexible enough to accommodate a range of uses over time.

Atriums

Where atriums are proposed as a component of large multi-unit commercial or mixed use developments, efforts should be made to tie the interior and exterior spaces together.

The design of atriums should incorporate the following:

1. The use of vision glass.
2. The coordination of materials and finishes from inside and outside the building.
3. Patios and other elements that can create a seamless indoor-outdoor transition are encouraged adjacent to atriums.

2.6 Parking

General Provisions

1. Parking lots and structures should be designed to minimize the number of curb-cuts required for ingress and egress.
2. Shared ingress and egress points between two or more separate parking facilities are encouraged.
3. Curb-cuts should be set back from corners and intersections in accordance with By-Law requirements, or as may be determined to be necessary by the City Engineer.
4. It is preferred that entrances to parking facilities not occur on the following streets:
 - Wellington St between York and Victoria Park
 - Dundas Street
 - Richmond Street

5. Parking facilities with controlled access points should provide sufficient stacking space for vehicles outside of the right-of-way. A minimum of one car length (6m) between the control point (ticket booth, etc.) and the inside edge of the sidewalk is encouraged.
6. Sufficient sight lines shall be required from parking lot exits to provide safe vehicular crossing of the pedestrian right-of-way.

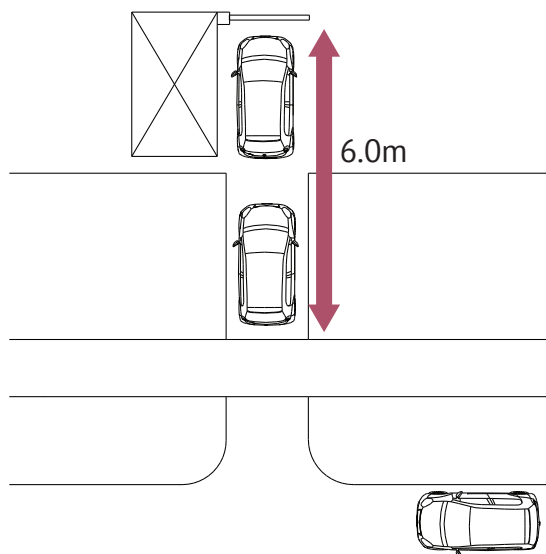

Stacking lanes for parking lots and structures

Surface Parking Lots

1. Surface parking areas should be screened from the street by landscape walls with a minimum height of 1.0m, subject to the retention of required sight lines on corner properties.
2. Wall materials should be consistent with the building materials of surrounding structures, or of brick or cut stone.
3. Chain link fences, pressure-treated timber, and wood are not considered to be appropriate along the street frontage in any Downtown locations. The paving treatment of adjacent sidewalk areas should continue across entrances and exits to parking areas.
4. Interior areas of surface parking lots are encouraged to be paved and provided with landscaping in order to improve the visual quality of these large open spaces.

Surface Parking Lot Landscaping

1. Surface parking lots require a 3m setback from the street line and a 1.5m setback from any property line. These setback areas are to be landscaped.
2. Landscaping may be used for screening in conjunction with, but not instead of, walls. Landscaping alone is not sufficient. It is subject to wear and tear in urban areas, and does not provide effective screening during the winter.
3. Coniferous shrubs should be used for landscape screening materials.
4. Large coniferous trees are inappropriate as screening material Downtown, and are better suited to large-scale spaces and open landscape areas.

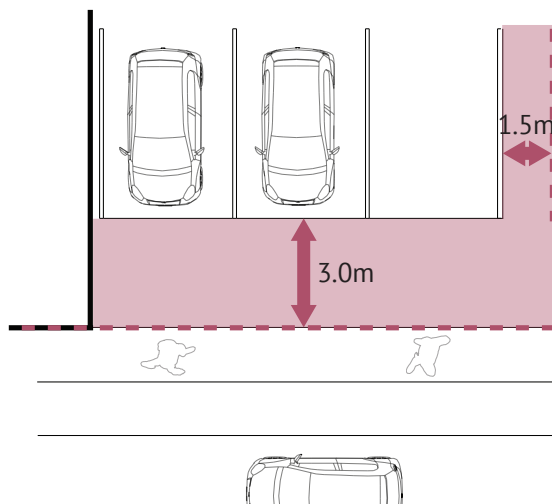

Provide sufficient landscaped setbacks

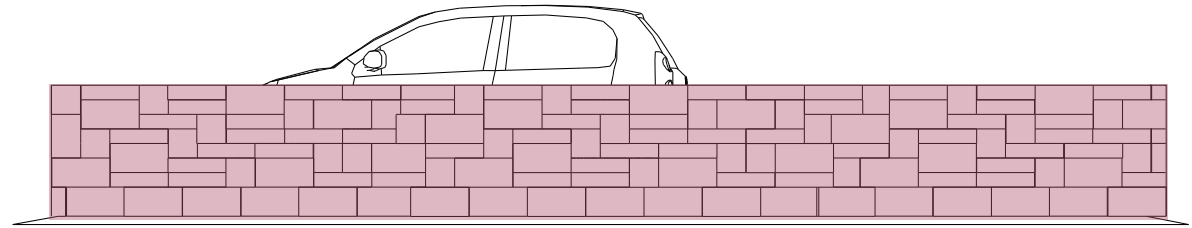

Screen parking with landscape walls

Parking Structures

1. The ground floors of parking structures that face the street should contain pedestrian-oriented uses such as retail or personal-service uses. Continuous blank walls are discouraged.
2. Parking structures should be integrated into the overall structure of a building or large-scale development rather than as a free-standing structure, to reduce the visual impact on Downtown.
3. The architectural treatment and materials of parking structure facades should be the same as those used on other building(s) in the development.
4. Parking structure facades visible from the public realm should incorporate vertical architectural elements to maintain the small scale environment.
5. Ground level facades of parking structures that do not incorporate retail or other active uses along the public sidewalk should be designed to screen views of the interiors. Perforated grilles or screens are one method to accomplish this.

Service and loading facilities in densely developed urban areas such as Downtown London often conflict with pedestrian

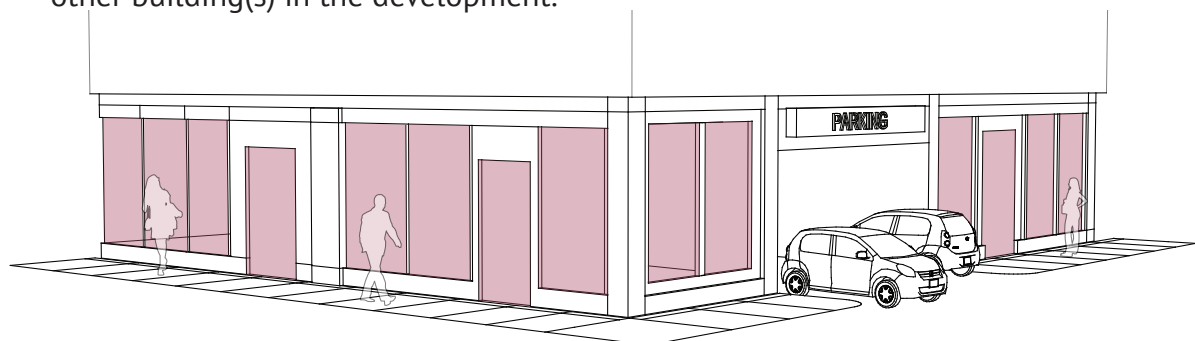

Wrap parking structures with active uses

2.7

Service & Loading

movement, and if not properly designed, can negatively impact the visual environment. The following guidance aims to minimize the potential adverse effects of these facilities.

1. In order to minimize the disruption of pedestrian movement on important pedestrian-oriented streets in Downtown, loading and service areas are strongly discouraged along the following streets:
 - Wellington St between York and Victoria Park
 - Dundas St in the Downtown
 - Richmond St in the Downtown

2. It is encouraged that service and loading facilities be provided within the building, enclosed from views from public spaces.
3. Shared entrances to common loading and service areas are encouraged to minimize the number of curb-cuts on a given street. Developers are encouraged to work with the owners of adjacent properties, through the Site Plan Review process, to provide shared entrances and facilities.
4. Where loading and service areas must be located along the street frontage of a building, these entrances be located at mid-block.

5. Entrances to service and loading areas should be architecturally integrated into the building facade and should not be a dominant visual feature from the public right-of-way.
6. Where sight lines and turning radii permit, service and loading facilities and their entrances should be perpendicular to the street to minimize their presence at the building line.
7. Where parallel or angle loading and service areas are necessary for functionality, the side of the service area facing the public right-of-way should be visually screened and integrated into the architectural treatment of the building.

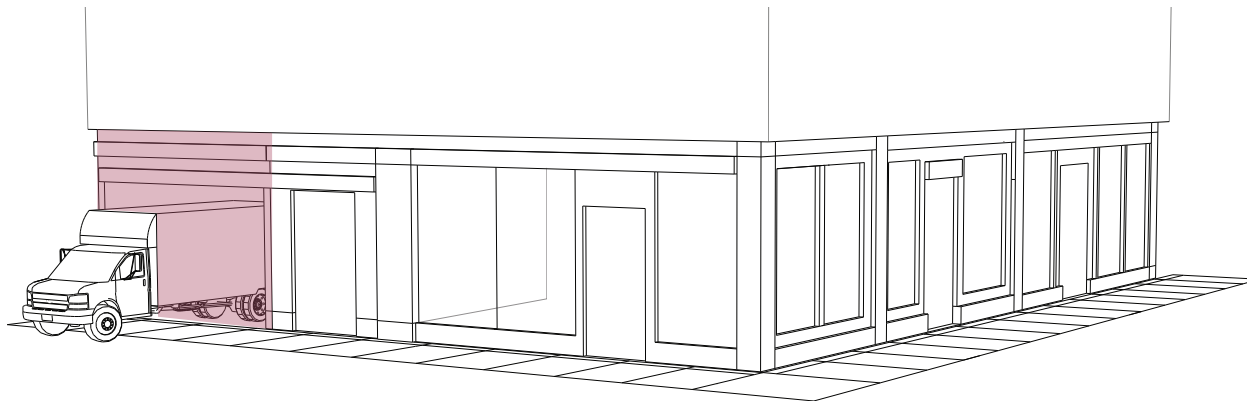

Integrate entrances into the building facade

8. Unless otherwise required by the Zoning By-Law, buildings should have no more than two service bays located on the street. These service areas should be constructed with sufficient depth to allow service vehicles to be located out of the right-of-way. Opaque doors should be used to screen these service bays when they are not in use.

9. Where site conditions or building design require a change of grade between the level of the loading and service area and the street, the grade change should be incorporated within the structure or behind a garage door or gate.

This will help to avoid conditions that create “cave-like” service entrances along the street.

Interface with the Sidewalk

1. The sidewalk surface treatment should continue across the entrance to any loading or service area to maintain the continuity of the pedestrian walkway.
2. Sufficient sight lines should be retained from loading and service areas across the pedestrian right-of-way.
3. In instances where the preceding guidelines may not be possible or practical, service and loading activities are encouraged to take place outside of regular business hours to minimize disruption of the Downtown pedestrian environment.
4. Ensure that vehicular driveways and laneway access points are minimized to enhance pedestrian and cycle safety.

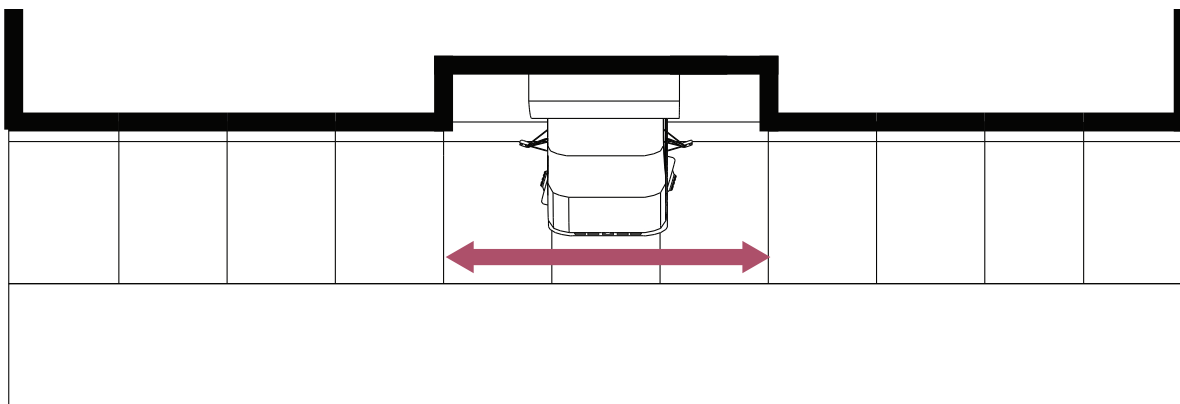

Minimize openings in the streetwall and ensure a continuous sidewalk surface

3.0

Patio

Design Guidelines



3.1

Purpose

The following guidelines illustrate the design requirements for patios within the public right-of-way. While encompassed within the Downtown Design Manual, these guidelines may apply to patio establishment throughout other parts of the city.

The intention is to ensure that universal access, public safety and the streetscape experience are enhanced and not negatively impacted by the introduction of a patio.

Sidewalk patios can bring activity to the street and create a more vibrant urban atmosphere for those who experience the space. By providing opportunities for outdoor dining, the City, and establishments within it, can encourage use and enjoyment of the outdoor environment.

In order to establish a sidewalk patio, an applicant must consult with city staff and follow this illustrated step by step guide to determine the location, features and materials.





3.2

Application Process

The process to developing a sidewalk patio consists of eight steps, to ensure the use of City property is in compliance with the guidelines and requirements set out by the City to protect the public.

Steps in the Application Process

1. Consult

Meet with staff to discuss your desire to develop a sidewalk cafe within the Public Right of Way.

2. Select Patio Location

Use this document to determine which patio location is best suited for your situation.

3. Plan & Elevation Drawings

Provide a plan (overhead view) that shows the design and layout for your patio, including compliance with the requirements and location of specific features, such as furniture and lighting.

Provide an elevation (street level view) drawing of your proposed cafe that shows all proposed features and compliance with design guidelines.

4. Photographs & Material Samples

Provide at least four images:

- View from the front,
- View from the right
- View from the left
- View in context of surroundings, including neighbouring properties and the streetscape.

If available, provide any samples, photographs, or drawings of design features such as furniture, plantings, awnings etc. to be used.

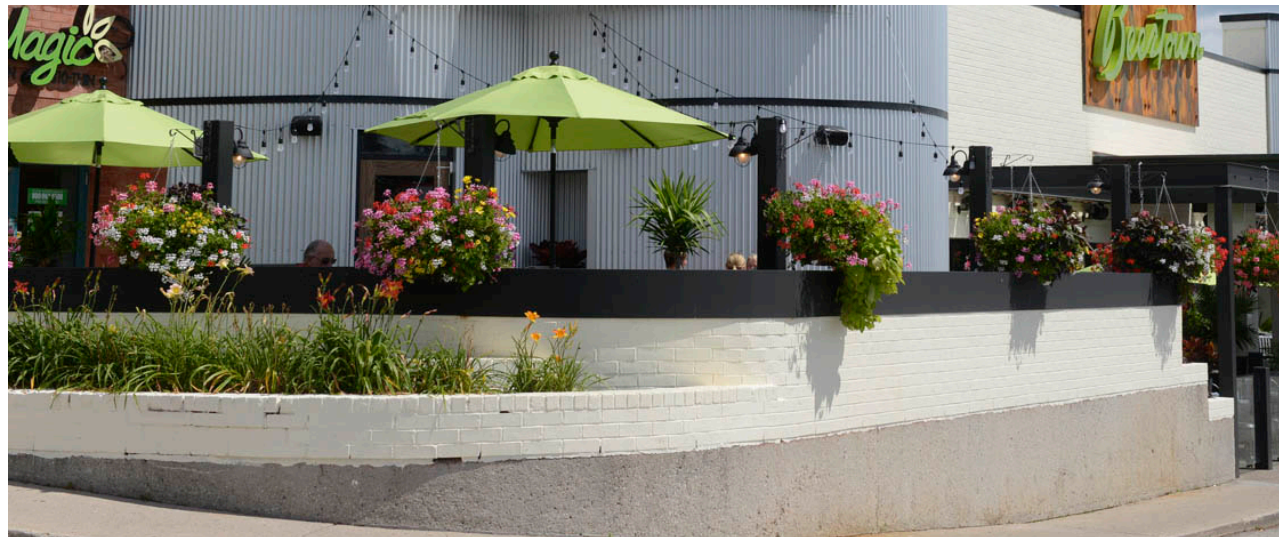

5. **Comply with Design Guidelines**

Follow the design guidelines to ensure your patio complies to the minimum standards and where standards are enhanced, meet the desired outcomes of these guidelines.

6. **Complete Form**

Complete the form, found at Realty Services.

7. **Submit for Staff Review**

Submit your application package to Realty Services.

Staff from various City of London departments will review your application and consider it for approval or recommend modifications. A licencing agreement will be entered into and a new application is required each year.

8. **Construct & Operate**

Once your patio has been approved, you can construct and operate your sidewalk patio in compliance with your approved submission package.

Annual licensing is required to operate a Sidewalk Patio. The license can be obtained through Realty Services.



3.3

Classifications

There are several potential sidewalk patio locations within the public Right of Way. Each location is suitable in different scenarios and choosing the right location for your situation will ensure the streetscape is enhanced and the safety of patrons and members of the public is secured.

When choosing the location of a patio, key considerations include the existing streetscape, surrounding uses, and availability of space.

Patios are to respect their adjacent establishments and considerations must be made to the flow of pedestrian traffic. Proposed patios are to operate within the available Right of Way without interfering with pedestrian traffic movements.

The following pages explain in detail each of the six potential patio locations and include minimum and maximum measurements related to each situation.

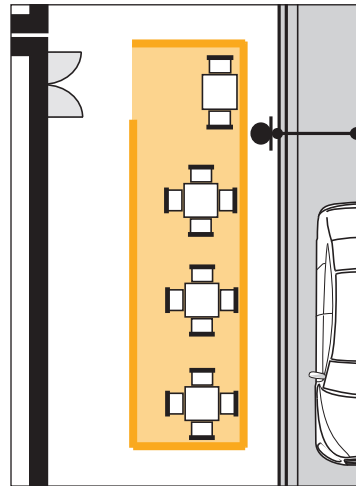

Along the Curb

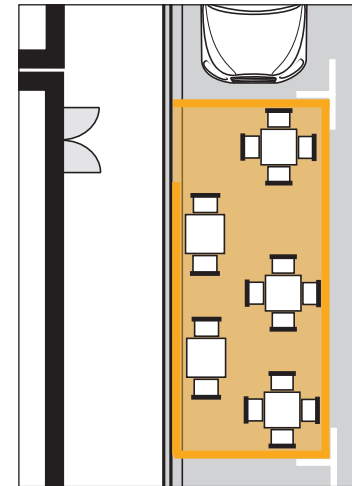

On-Street Parking

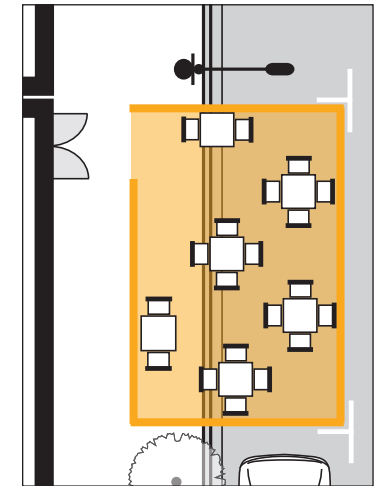

Combination

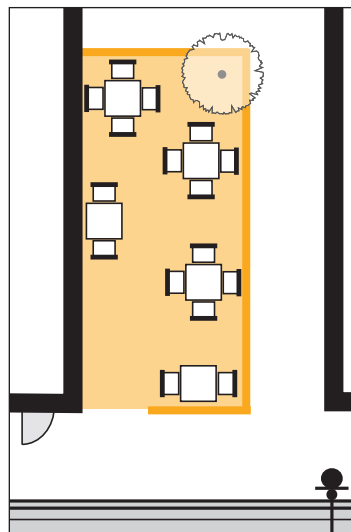

Alleyway

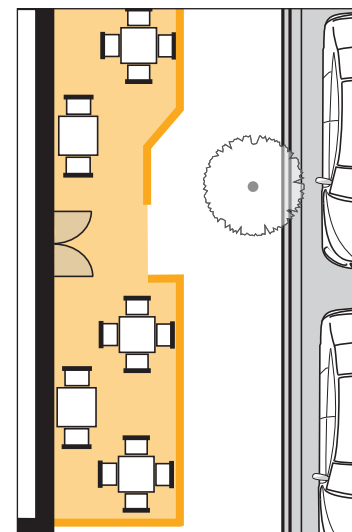

Along Building

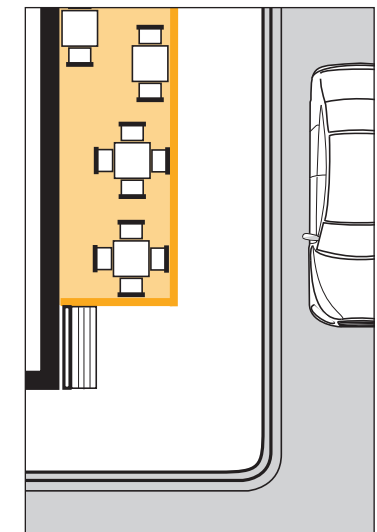

At A Corner

Along the Curb

1. Patios along the curb are located on the exterior edge of the public Right of Way with the clearway located between the building and the patio.
2. Between the boundary of the patio and the curb, a minimum buffer of 0.25m must be provided.
3. This location is most preferred as it maintains a consistent flow of pedestrian traffic along the fronts of shops and businesses, while still providing the patio.

Summary of Required Distances

Clearway	1.5m (min)
Distance from Curb	0.25m (min)
Entrance	1.2m (min)
Distance from Streetscape Objects	1.5m (min)

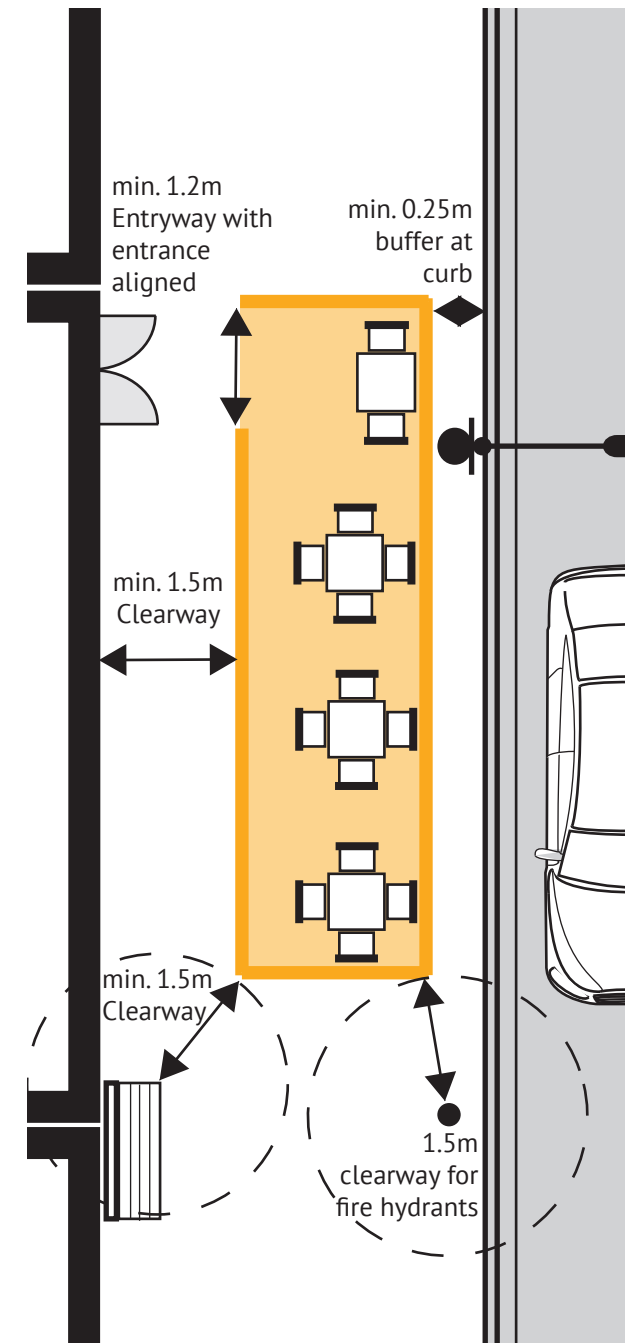

In On-Street Parking Space

1. Where the public right-of-way is not large enough to support a patio on the sidewalk, patios may be located within an on-street parking space subject to an agreement with the City.
2. The clearway shall be located between the curb and the associated building.
3. Patios located within an on-street parking space must be brought to the same height as the sidewalk.
4. Patios in on-street parking spaces may only occupy complete spaces and shall have a minimum of 4m of the parking space located directly in front of the associated establishment.
5. This location is also preferred for its minimal effect on the flow of traffic within the public right-of-way.

Summary of Required Distances

Clearway	1.5m (min)
Length	8m (min) [1 parking space]
Entrance	1.2m (min)
Distance from Streetscape Objects	1.5m (min)

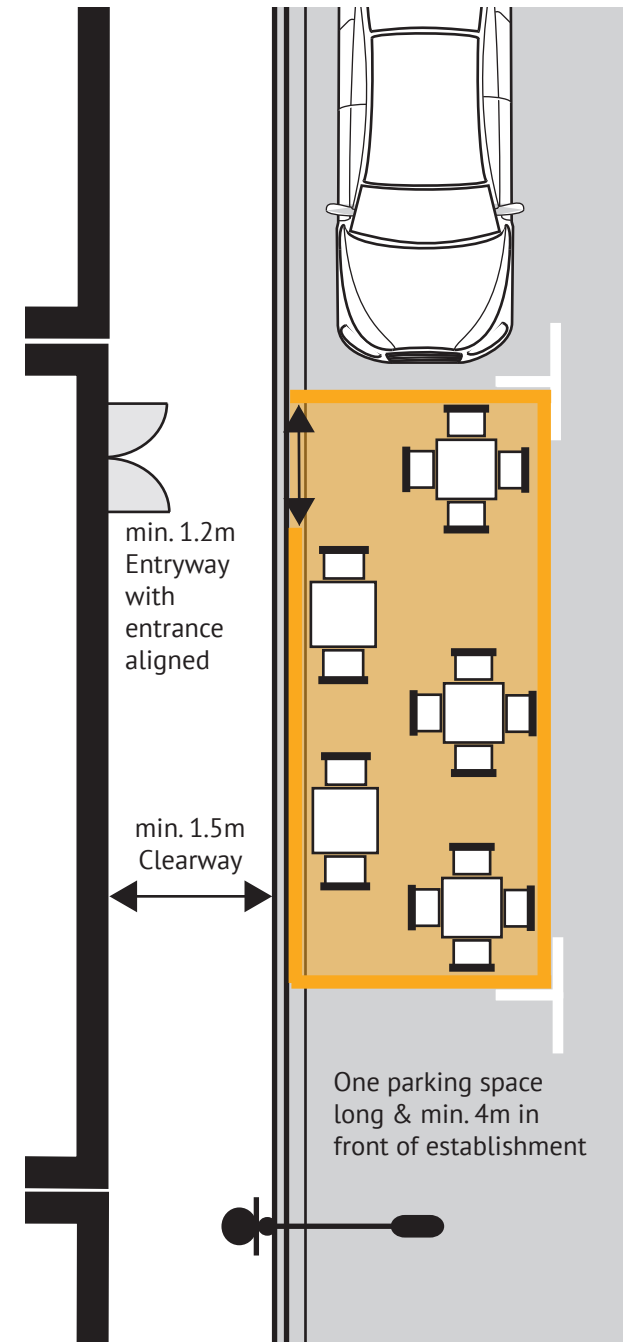

Boulevard & On-Street Combination

1. In order to create a larger patio, it may be suitable in some cases to combine a patio in the boulevard with a patio in an on-street parking space. The combined, enlarged space will act as one patio.
2. The clearway shall be located between the interior boundary of the patio and the associated building.
3. The use of an on-street parking space is subject to an agreement with the City.
4. The portion within the on-street parking space must be brought to the same height as the public Right of Way. A level transition between the two portions shall be provided.
5. Like options A and B, this is also preferred for its ability to accommodate more patrons while maintaining a clearway for consistent flow of pedestrian traffic along storefronts.

Summary of Required Distances

Clearway	1.5m (min)
Length	8m (min) [1 parking space] 1m (max) [beyond property]
Entrance	1.2m (min)
Distance from Streetscape Objects	1.5m (min)

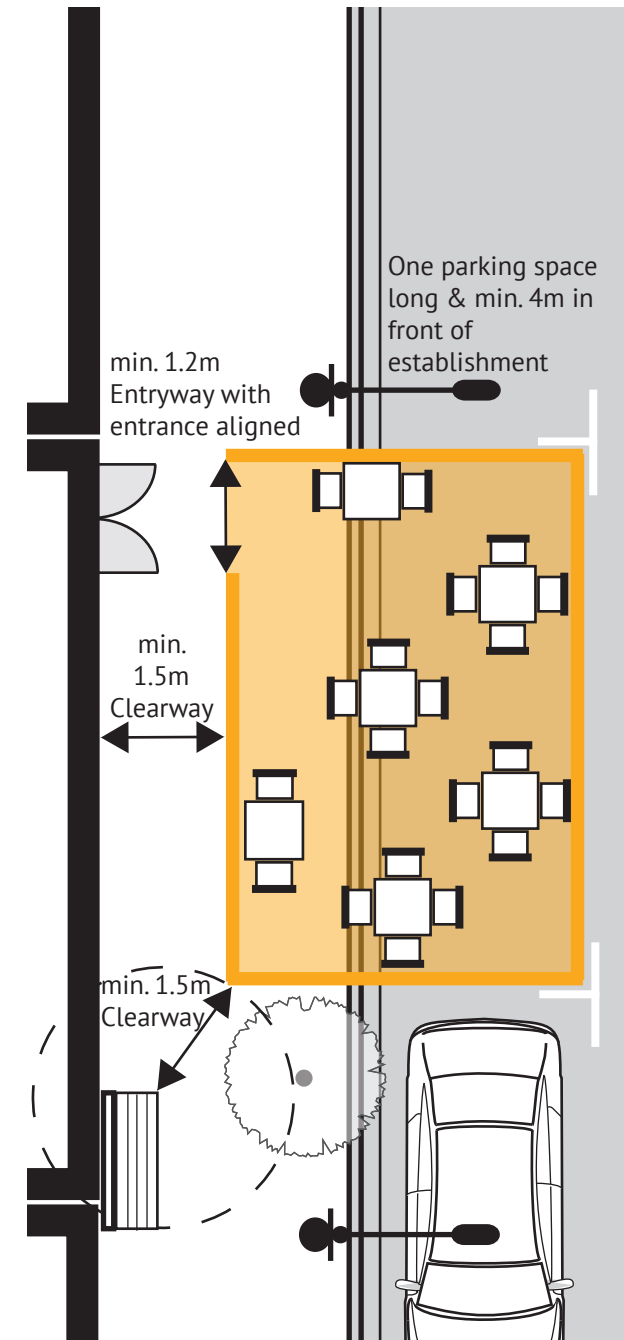

Alleyways

1. Where there is a public alley between two buildings, a patio may be located in the space adjacent to the establishment provided the proposed patio does not prevent vehicular access.
2. Where vehicular traffic has an alternate route available or if vehicular access is not required, the patio may still be located within the alley, but shall provide a clearway for pedestrian access.
3. The clearway shall be located between the outer edge of the patio and any neighbouring buildings and/or the curb.
4. The entrance to the patio should be located as close as possible to the entry of the associated establishment. This will provide ease of access for the patio to serve patrons.

Summary of Required Distances

Clearway	1.5m (min)
Entrance	1.2m (min)
Distance from Streetscape Objects	1.5m (min)

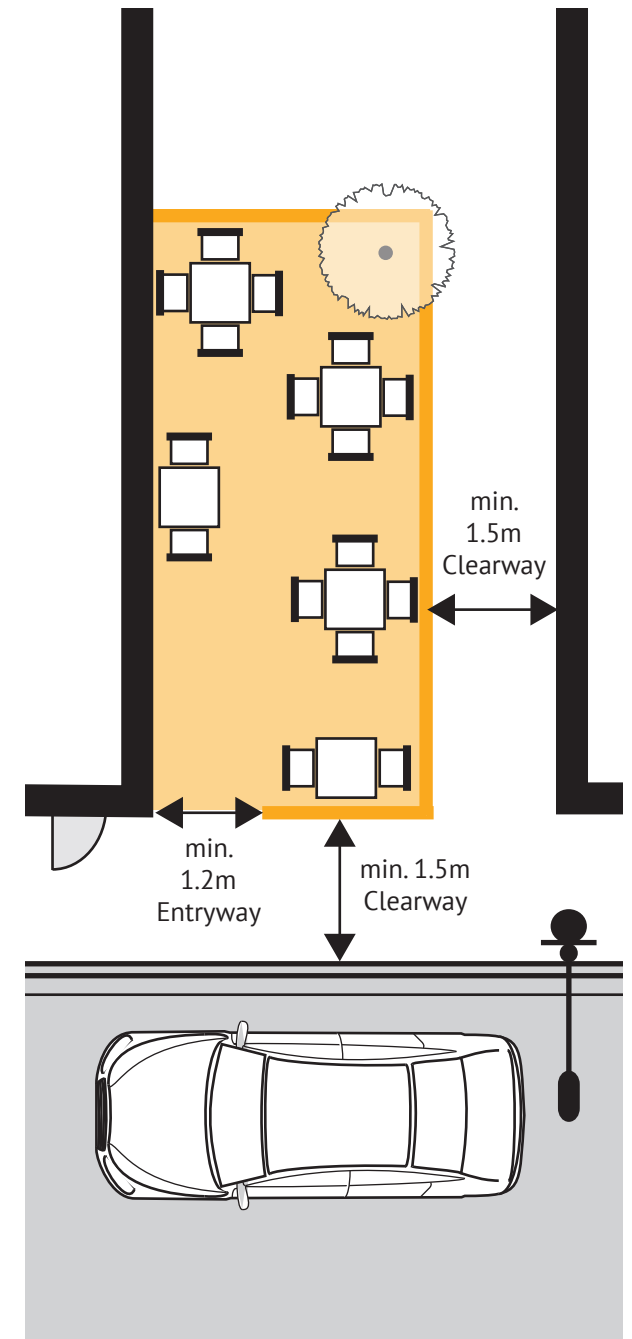

Along the Building

1. This classification includes patios located immediately adjacent to the building, but extending beyond the front property line into the public Right of Way.
2. The clearway shall be located between the outer edge of the patio and the curb.
3. This patio location is the least preferred as it causes a zig zag effect for pedestrian traffic. This location is particularly unsuitable where the existing streetscape consists of primarily retail shops that would not provide patios in the Right of Way. Should this patio location be the only viable option, it will be permitted provided these guidelines are followed and implemented.
4. Where patios can be located elsewhere, this location should not be considered.

Summary of Required Distances

Clearway	1.5m (min)
Entrance	1.2m (min)
Distance from Streetscape Objects	1.5m (min)

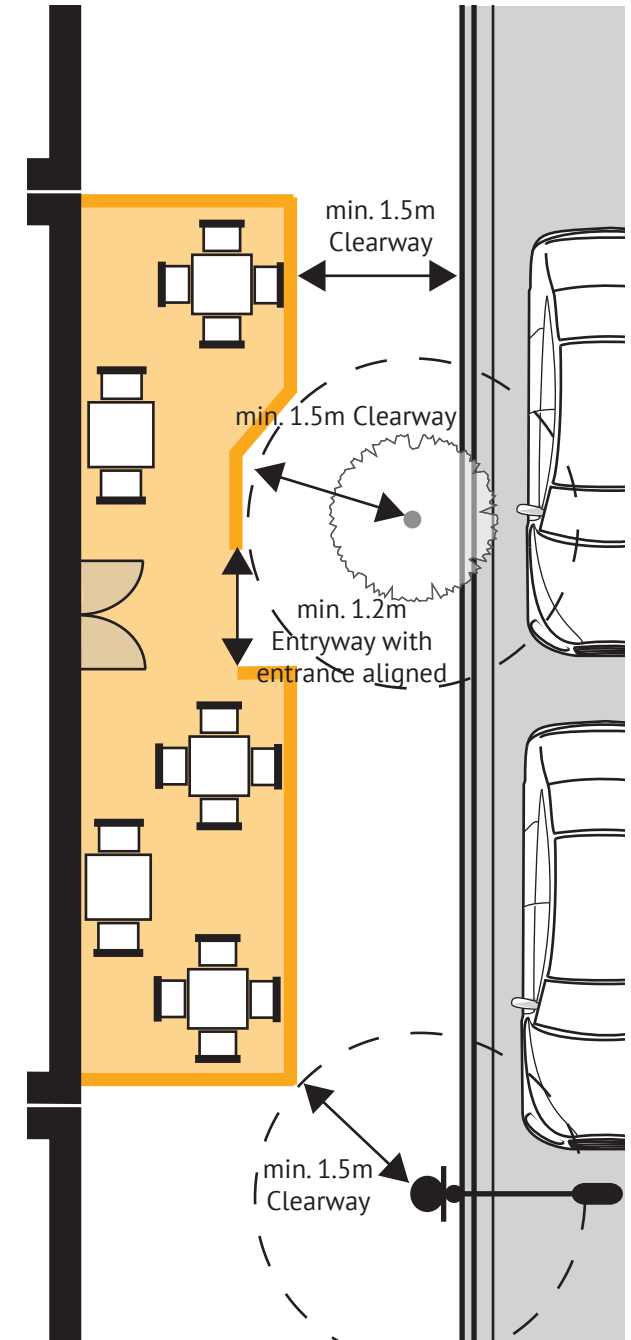

Patio At A Corner

1. Corners and intersections require special treatment to ensure the increased pedestrian volumes and general activity can be accommodated without interference.
2. Where a patio is in close proximity to an intersection, an addition to the clearway is required.
3. From the corner of the intersection, a minimum clearway of 3 metres is required.
4. This clearway distance is required for patios located along the building at a corner and in the boulevard at a corner.

Summary of Required Distances

Clearway	1.5m (min)
Clearway from Corner	3.0m (min)
Entrance	1.2m (min)
Distance from Streetscape Objects	1.5m (min)

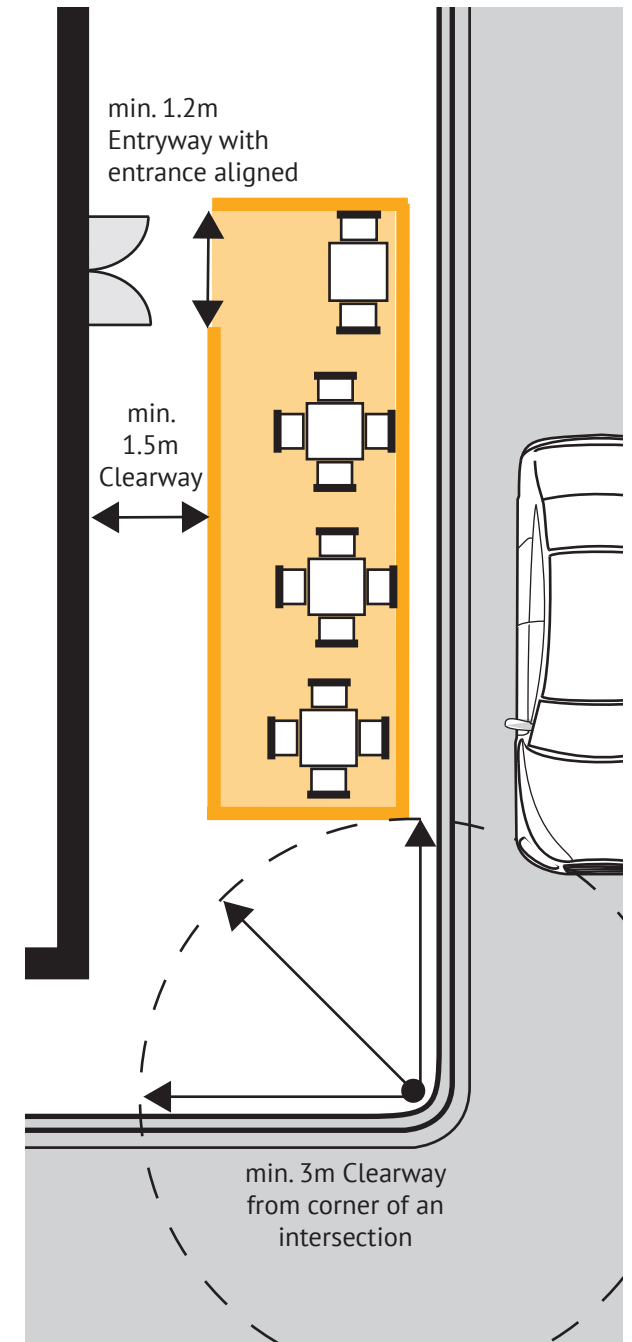
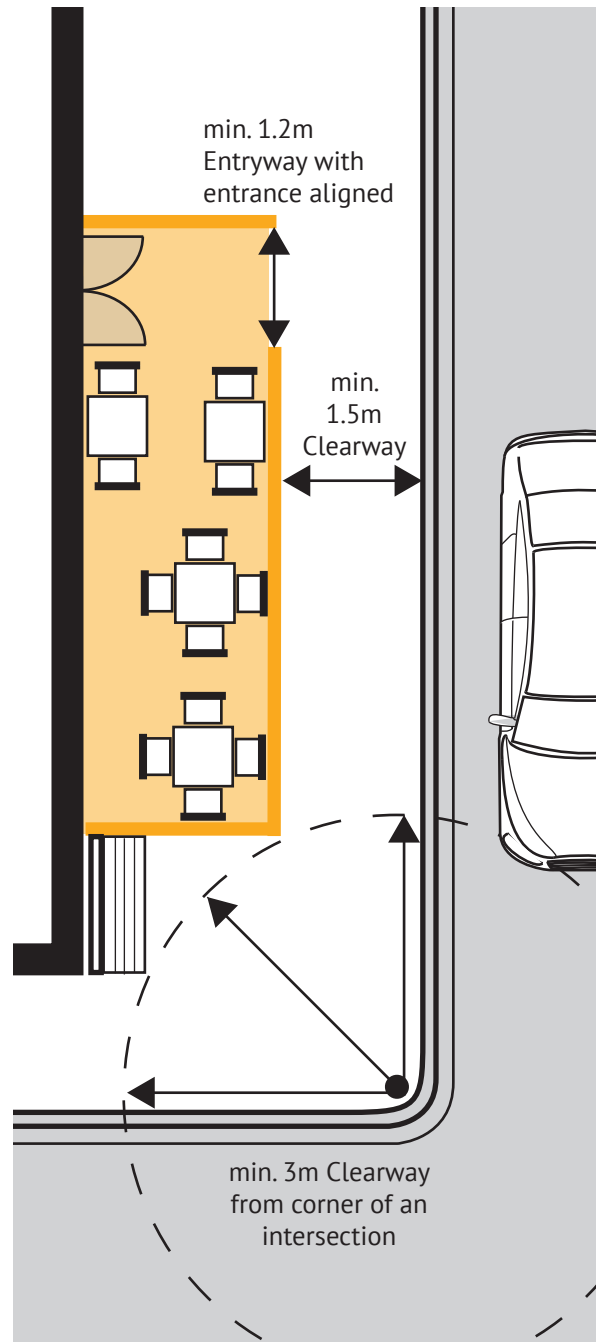



3.4

Design Details

Sidewalk patios will be comprised of structural, functional, and decorative features. To ensure public safety and general aesthetic continuity, the following design details provide the minimum requirements for various features within a sidewalk patio.

These design details include dimensions, locations, and materials for features such as furniture, fencing, lights, and plant materials.

The City encourages creativity and the development of unique outdoor dining spaces within the requirements provided.

Functionality

1. Clearway

An unobstructed pedestrian pathway of at least 1.5m must be maintained at all times. The location of the clearway relative to the patio will depend on the location of the patio.

Patios located at a corner will require a clearway of 3m from the corner of the intersection.

2. Entryway

An entryway of at least 1.2m must be provided to the patio, and where possible, should be aligned with the entrance to the corresponding establishment.

When entrances cannot be aligned, they should be provided in close proximity to each other to ensure ease of movement and service between the establishment and the patio.



Clearway

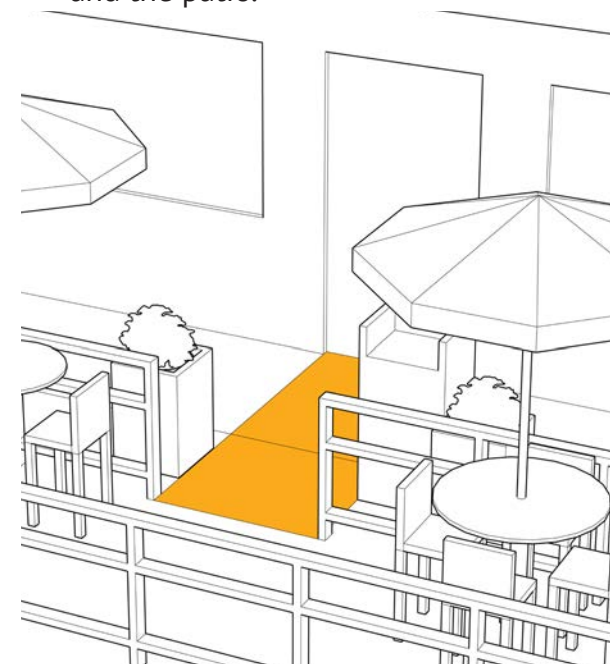

Entryway

3. Streetscape Elements

Streetscape elements shall not be located in the clearway. These include, garbage receptacles, tree grates, fire hydrants, street furniture, and any other item that poses an obstruction within the clearway.

Fire hydrants require a 1.5m buffer at all times.

All other streetscape elements, outside of the clearway do not require a buffer.

Street trees may be incorporated into the patio as long as they are not within the clearway.

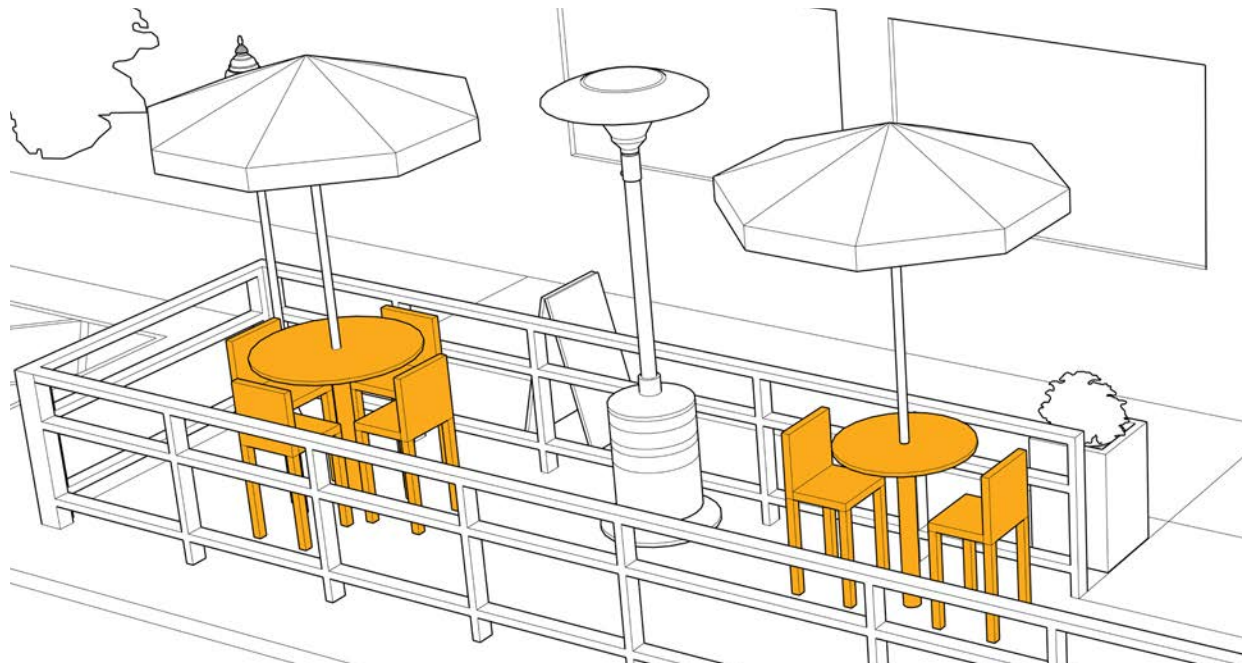
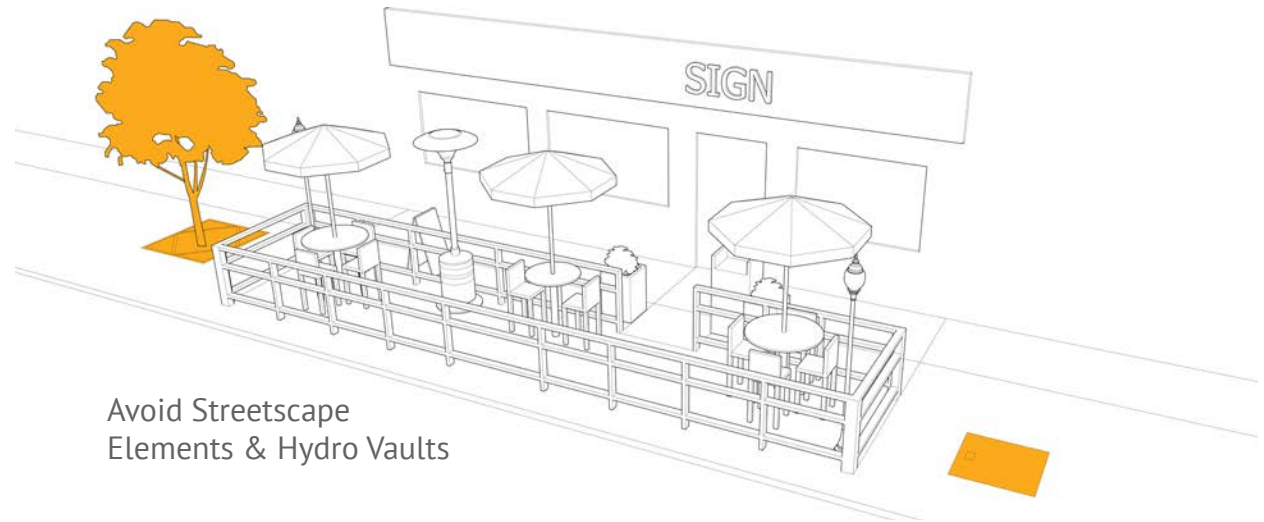

4. Hydro Vault

No patio can be situated on top of, or within 1m of an underground hydro vault.

5. Seasonal Use

Sidewalk patios, in their entirety, may only operate as seasonal features. All elements must be removable and disassembled at the end of the season.

6. Consistency

Tables and chairs should be made of matching sets and should be consistent throughout the patio.

7. Materials

All furniture, including fencing, should be made of durable, weather resistant materials, that are easily cleaned.

Composite, metal, or painted & stained wood is preferred. Pressure treated wood and plastic are strongly discouraged.

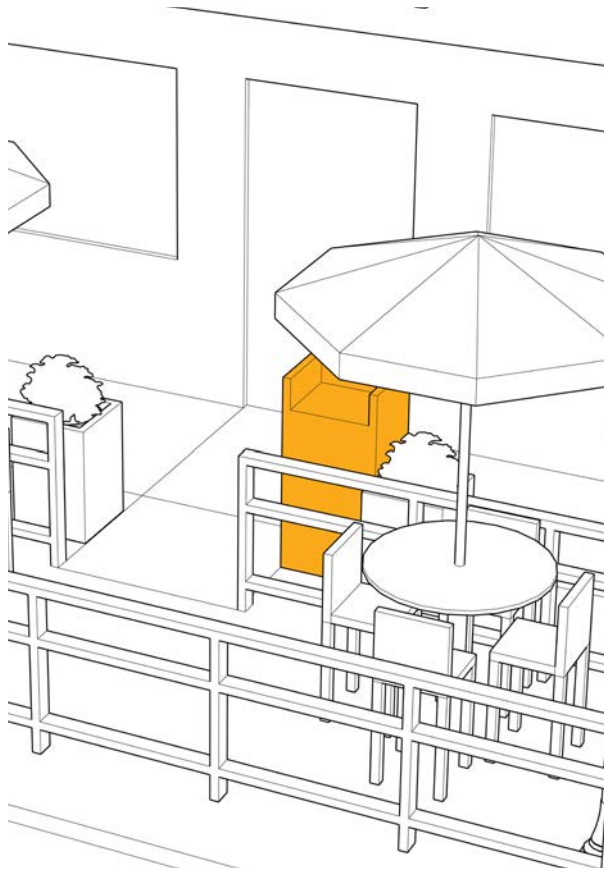

Host Stands

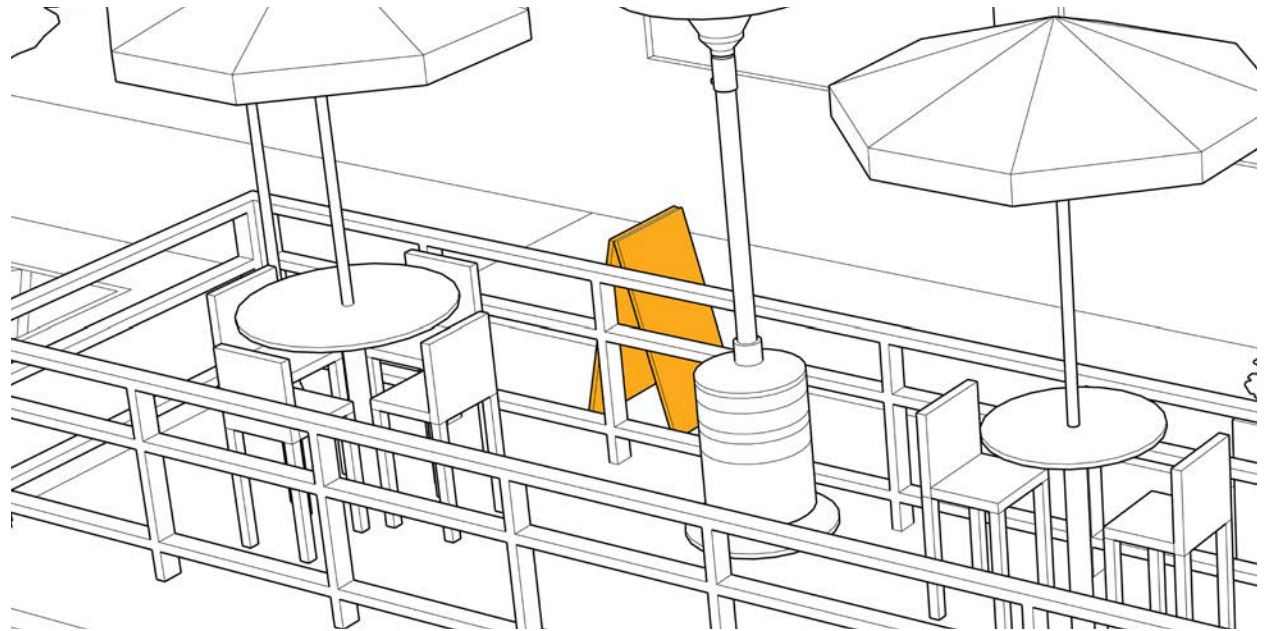

Menus & Sandwich Boards

Furniture

8. Host Stands

Host stands are permitted within the patio provided they are consistent with the furniture in the patio and do not enter the clearway.

9. Garbage Receptacles

Garbage receptacles are permitted within the patio provided they are located with host stands and cannot be seen as a prominent feature within the space.

10. Menus & Sandwich Boards

Menus and sandwich boards are permitted, provided they compliment the furniture within the patio and they do not enter the clearway.

Menus and sandwich boards may not obstruct views within or into a sidewalk patio. Therefore, menus and sandwich boards may not extend beyond 1 metre from the ground.

Fence and Plantings

11. Fences

Fencing is required when a business is licensed and serves alcohol on the patio. Patio fencing is optional for unlicensed establishments.

Regardless of a license, where a patio is located in an on-street parking space, fencing is required at all times.

Patio fencing must be 0.75-1m in height, and have a low barrier bar 0.15-0.3m high.

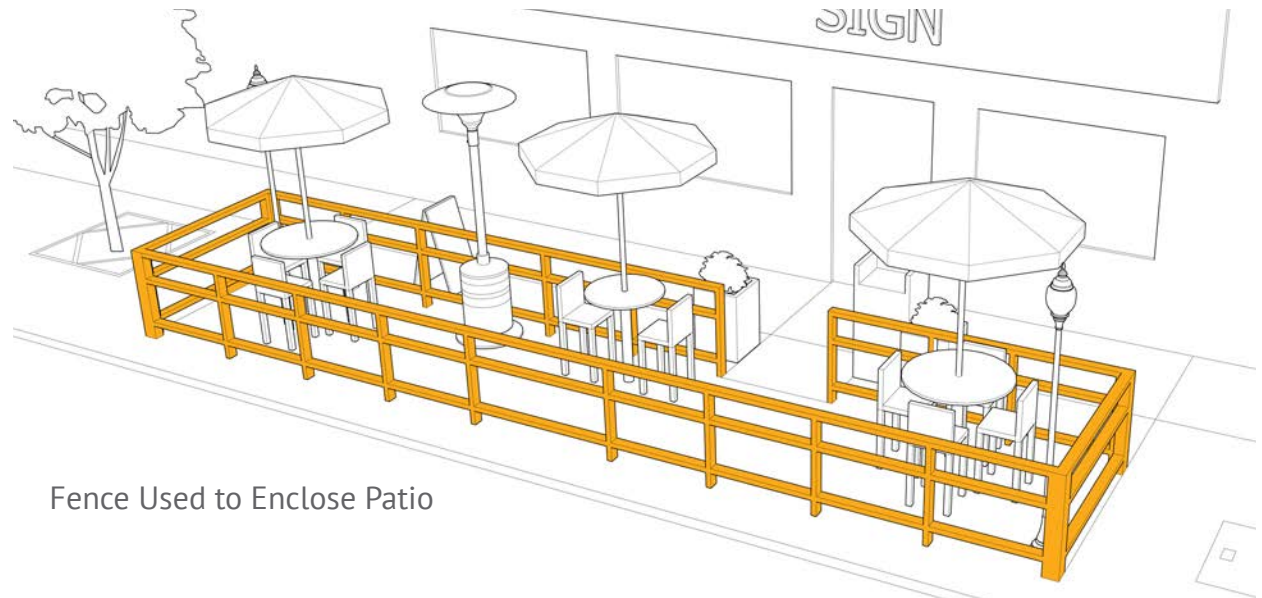

Fence Used to Enclose Patio

12. Plant Materials

Plants must be healthy, living and maintained throughout the season.

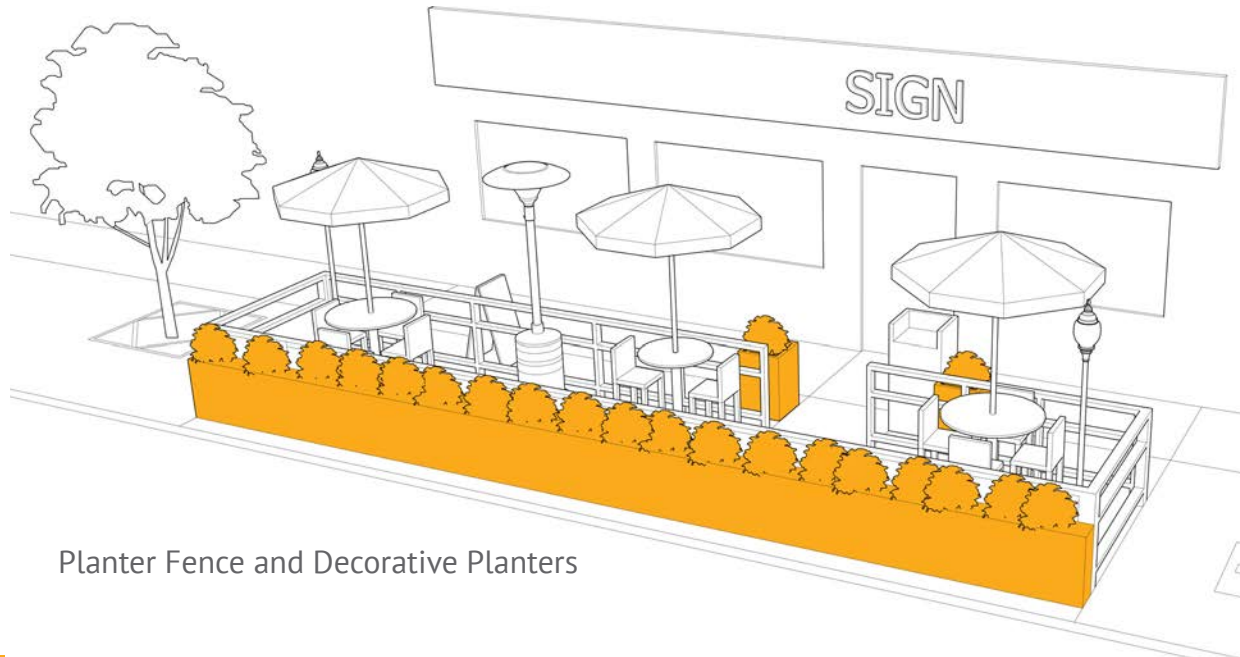

Planter Fence and Decorative Planters

13. Planter Fence

Planters can be used in lieu of a fence, but must be adequately sized to define the patio space.

The planter, with plants, must be 0.75-1m in height and must be a continuous length to delineate the patio space.

A 0.15-0.3m low barrier bar is required.

14. Decorative Planters

Ground planters may be used within the patio for decoration. The planters may not exceed 0.5m in width and 1m in height. Planters with plant material, may not exceed 1.5m in height.

Hanging planters may also be used. Plant material may extend a maximum of 0.5m from the hanging planter box.

Additional Features

15. Awnings & Umbrellas

Awnings and umbrellas must have a minimum height of 2.4m. Awnings must be installed on the first storey of the building.

When fabric is being used for awnings and umbrellas, flame and fade resistant materials are recommended.

16. Heaters

Heaters are permitted within the patio provided they do not exceed 3m in height.

17. Lights

Lighting for the patio is permitted, provided it is located within the boundaries of the patio and does not infringe upon the clearway.

Lights may not exceed 3m in height. The brightness of the lights should be sensitive to the uses surrounding the patio and should be directed onto the patio and away from neighbouring properties and the street.



Table Umbrellas

18. Paving

Site specific paving or surface treatment is not permitted in the public right-of-way.

Where paving surface is required, such as to level an on street parking space to the sidewalk, the material should be strong, durable, complimentary to the existing paving materials, and removable at the end of the season.

19. Third Party Advertisements

No third party advertisements shall be permitted on umbrellas, awnings, furniture or any element in the public right-of-way.

All other signs are subject to the City of London Sign and Canopy By-law.

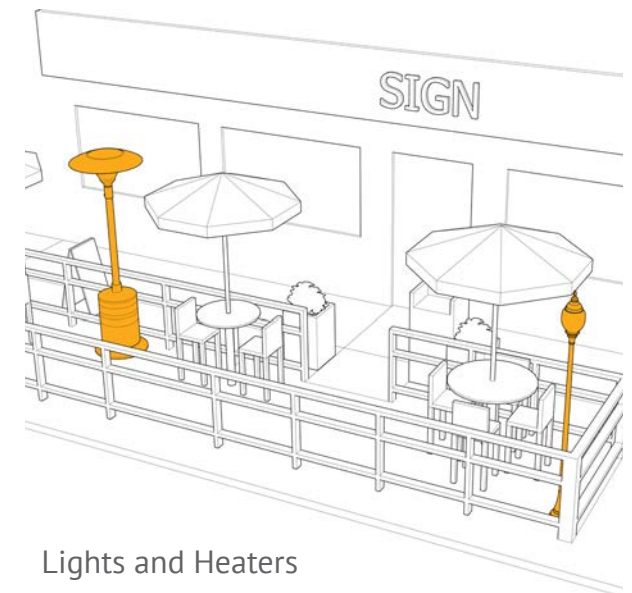

Lights and Heaters

