

Cycling Advisory Committee

Report

1st Meeting of the Cycling Advisory Committee
December 19, 2018
Committee Room #4

Attendance PRESENT: D. Mitchell (Chair), D. Doroshenko, D. Foster, R. Henderson, J. Jordan, W. Pol, R. Sirois, D. Szoller, M. Zunti; and P. Shack (Secretary)

ABSENT:

ALSO PRESENT: S. Harding, P. Kavcic, L. Maitland, A. Miller and S. Wilson

1. Call to Order

1.1 Disclosures of Pecuniary Interest

That it BE NOTED that no pecuniary interests were disclosed.

2. Scheduled Items

2.1 Wilton Grove Road Reconstruction Commerce Road to Westchester Bourne

That the following action be taken with respect to Wilton Grove Road Reconstruction-Commerce Road to Westchester Bourne:

a left turn lane BE CREATED on Wilton Grove Road to Old Victoria Road, heading south;

it being noted that the attached presentation from H. Houtari, Parsons Canada, with respect to the Wilton Grove Road Reconstruction Commerce Road to Westchester Bourne, was received.

3. Consent

3.1 11th Report of the Cycling Advisory Committee

That it BE NOTED that the 11th Report of the Cycling Advisory Committee, from its meeting held on November 20, 2018, was received.

4. Sub-Committees and Working Groups

That it BE NOTED that the Cycling Advisory Committee heard a verbal update from A. Miller, with respect to the inventory of public accessible bike parking racks in the downtown area.

5. Items for Discussion

5.1 ReThink Zoning Draft Terms of Reference

That it BE NOTED that the Cycling Advisory Committee held a general discussion with respect to the ReThink Zoning Draft Terms of Reference.

6. Deferred Matters/Additional Business

6.1 (ADDED) Lifestyle Home Show - A. Miller

That it BE NOTED that the Cycling Advisory Committee (CAC) held a general discussion and heard a verbal presentation from A. Miller, Coordinator, Transportation Demand Management, with respect to the CAC's participation at the Lifestyle Home Show.

6.2 (ADDED) Cycling Wrap Up Survey - D. Szoller

That it BE NOTED that the Cycling Advisory Committee 2018 Wrap Up Survey Questions document, as appended to the agenda, was received.

6.3 (ADDED) Transportation Advisory Committee Representative

That it BE NOTED that D. Foster is the representative of the Transportation Advisory Committee on the Cycling Advisory Committee.

7. Adjournment

The meeting adjourned at 6:05 pm.

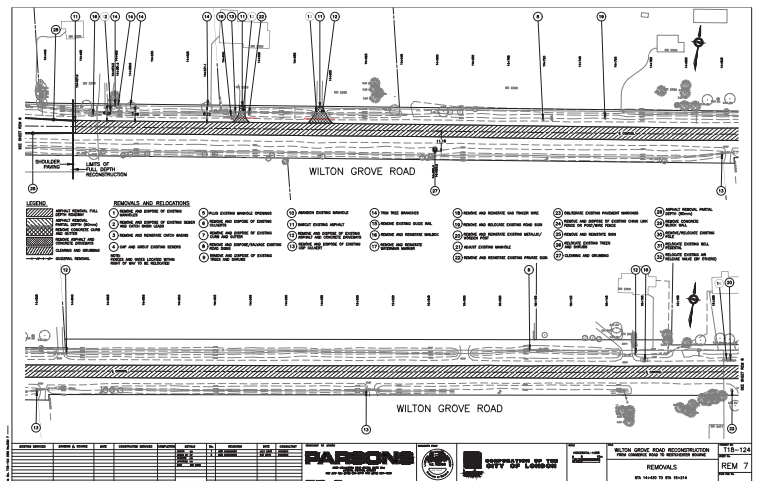
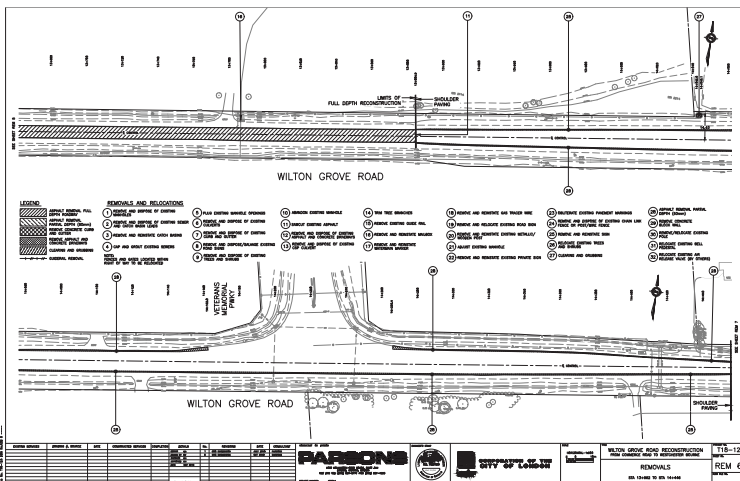
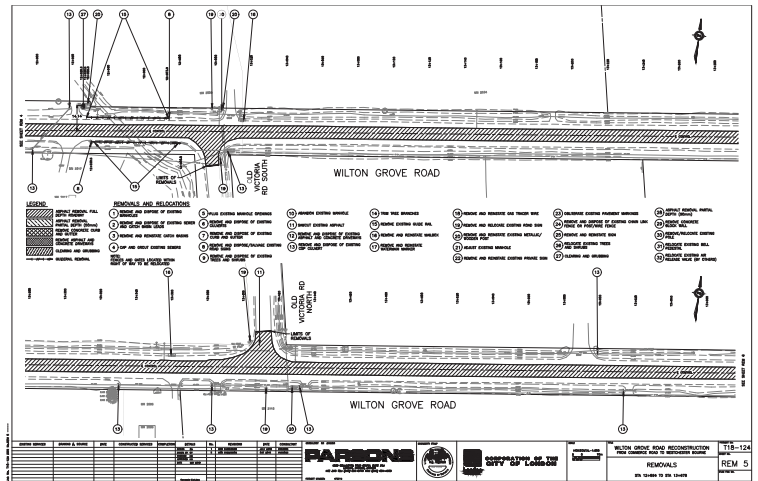
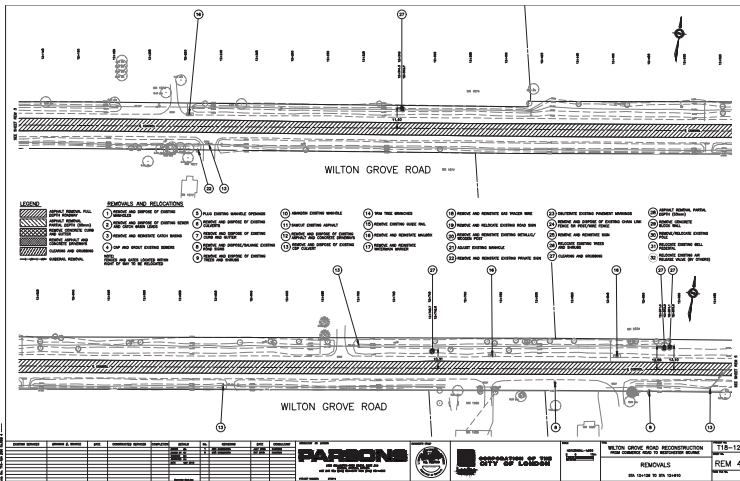
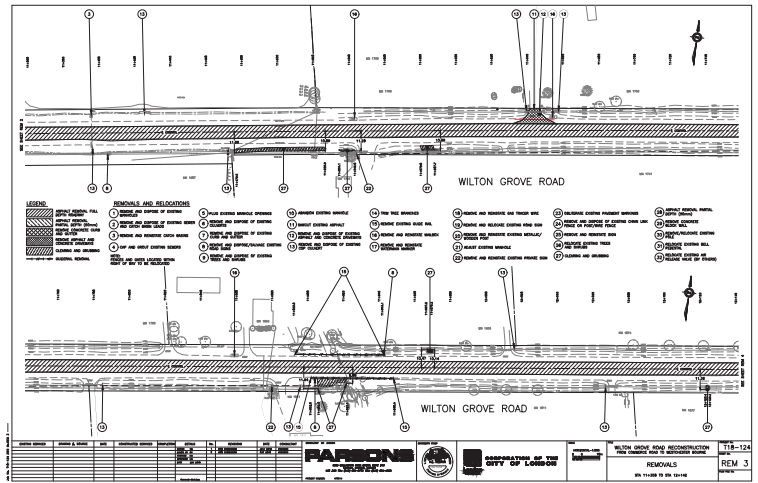
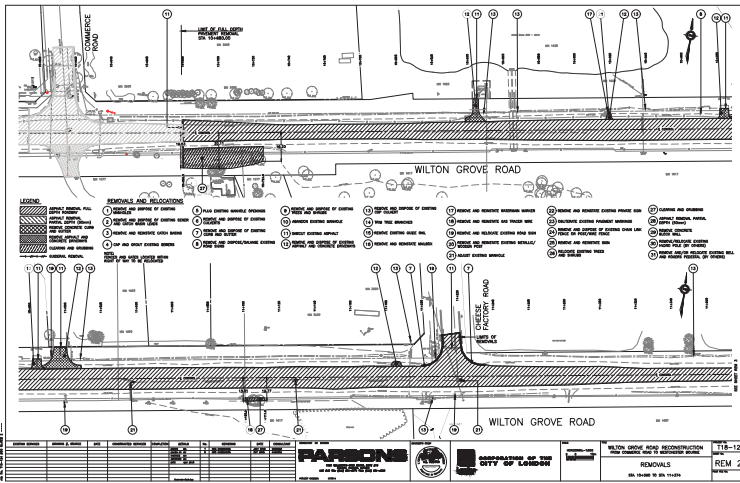

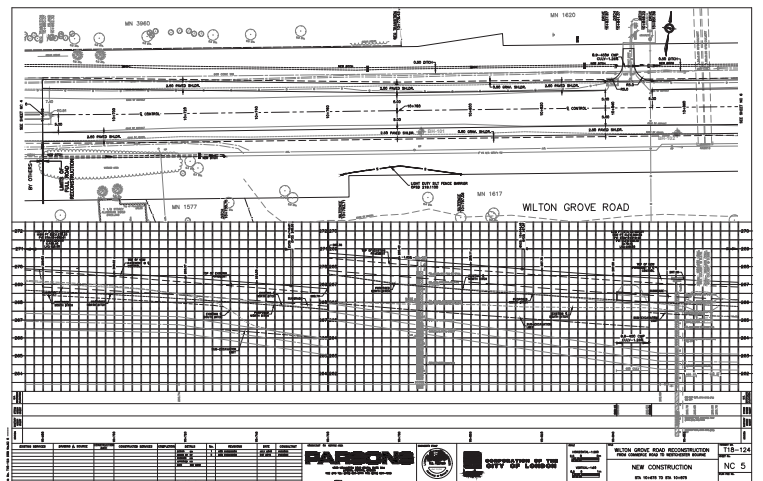
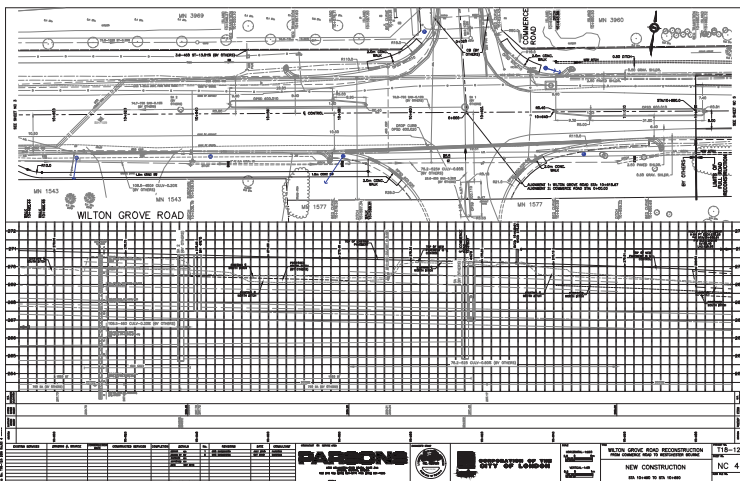
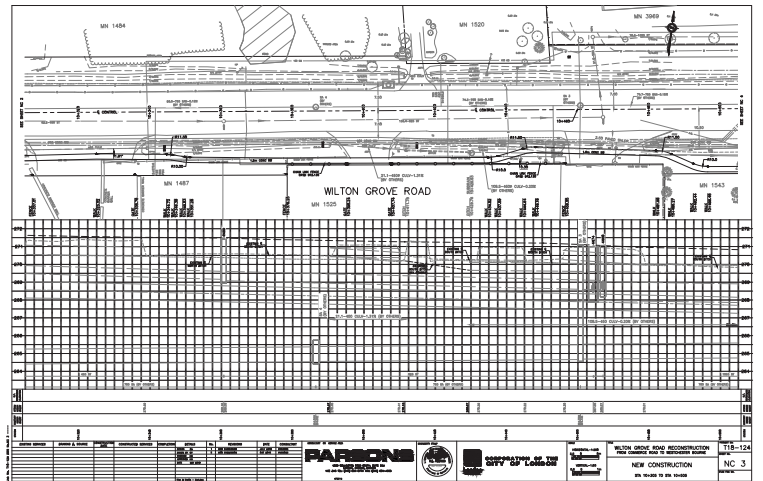
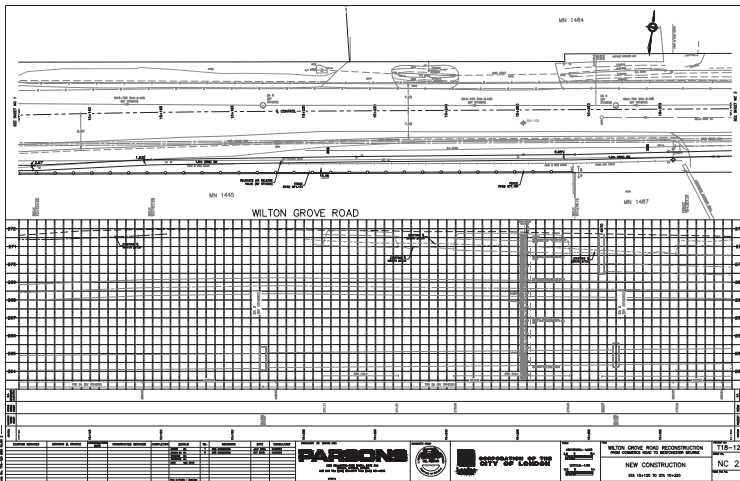
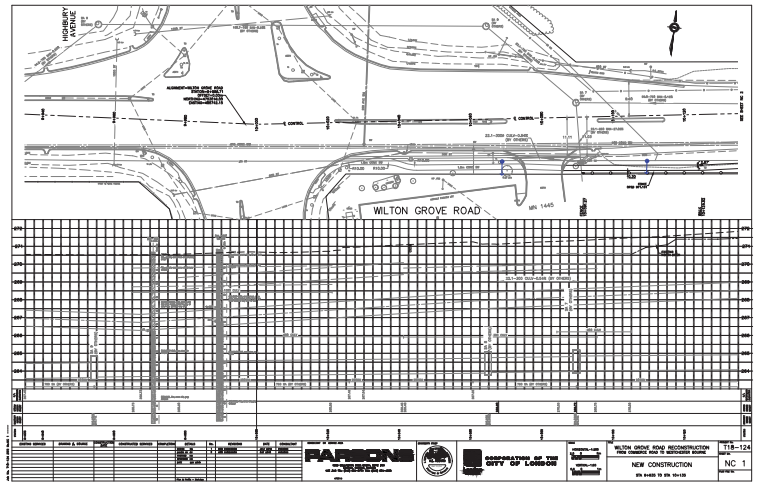
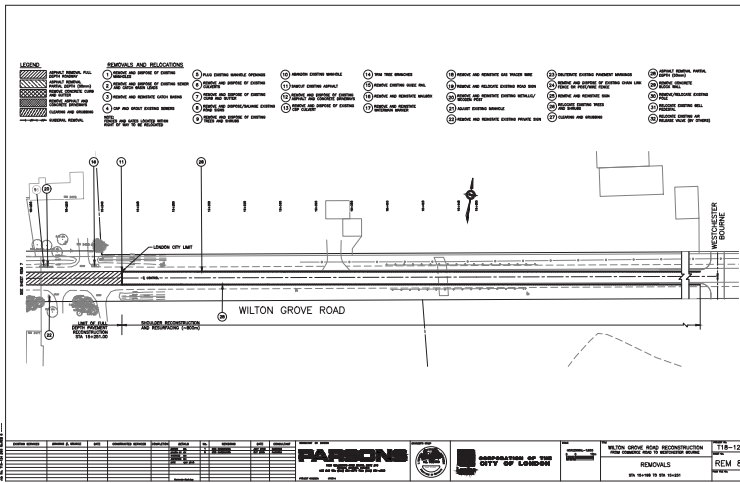

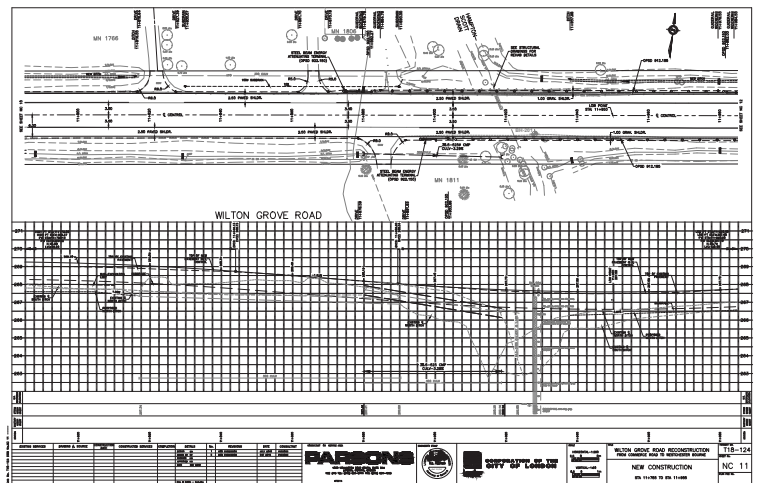
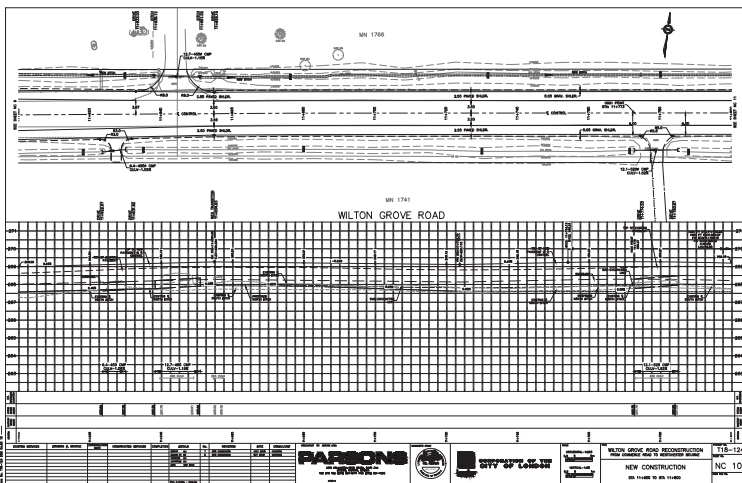
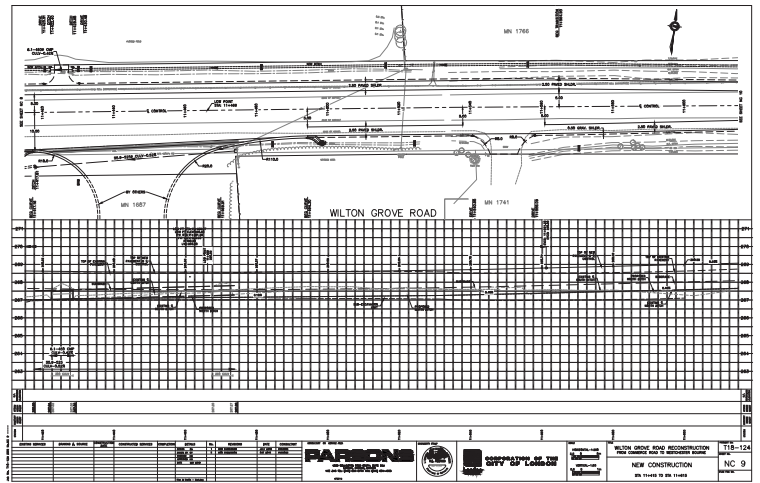
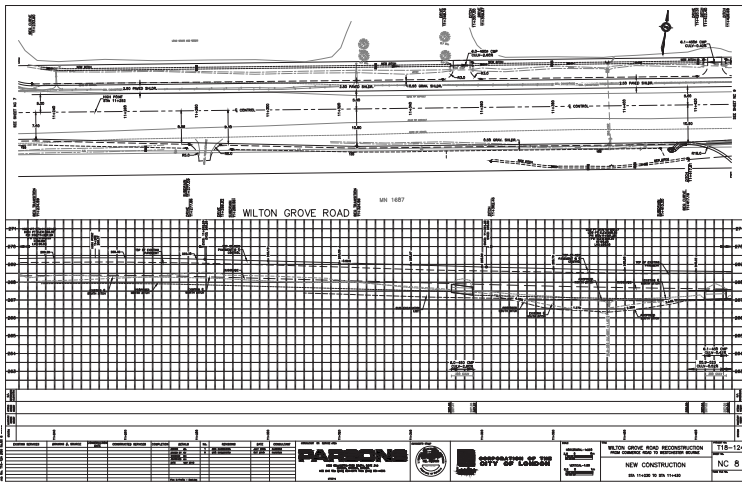
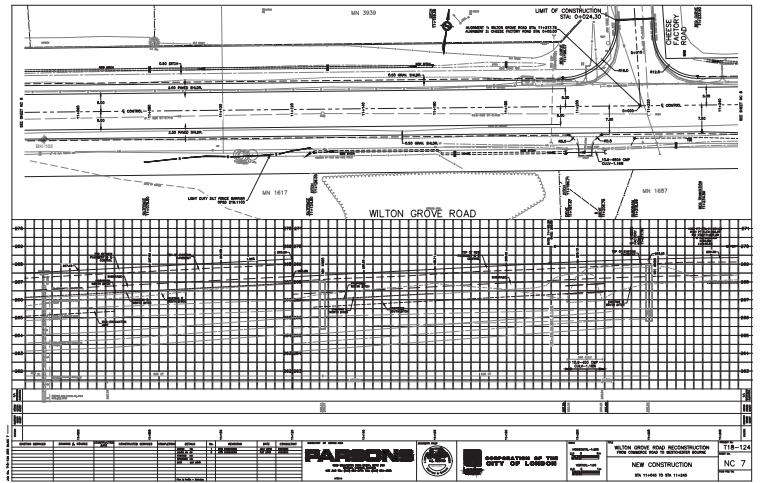
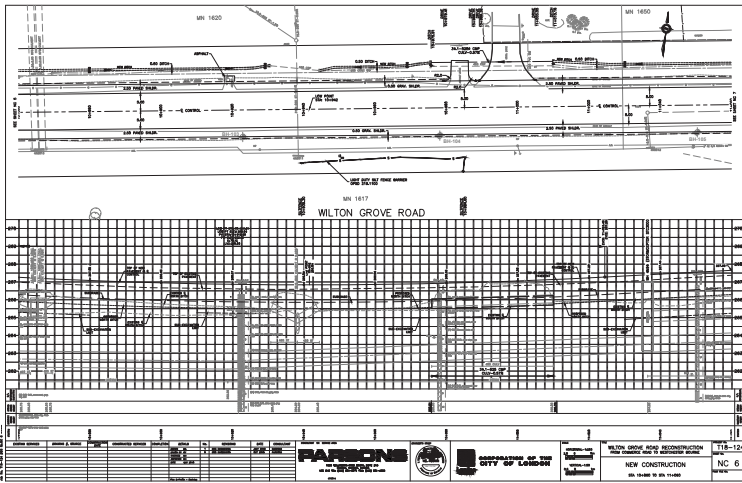

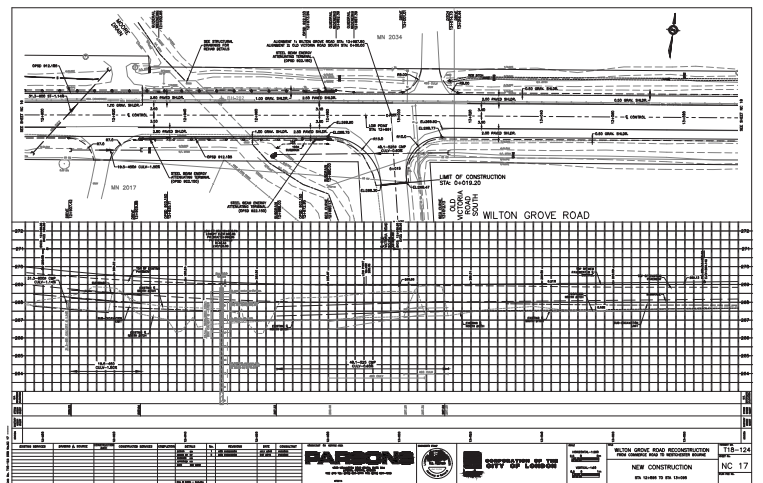
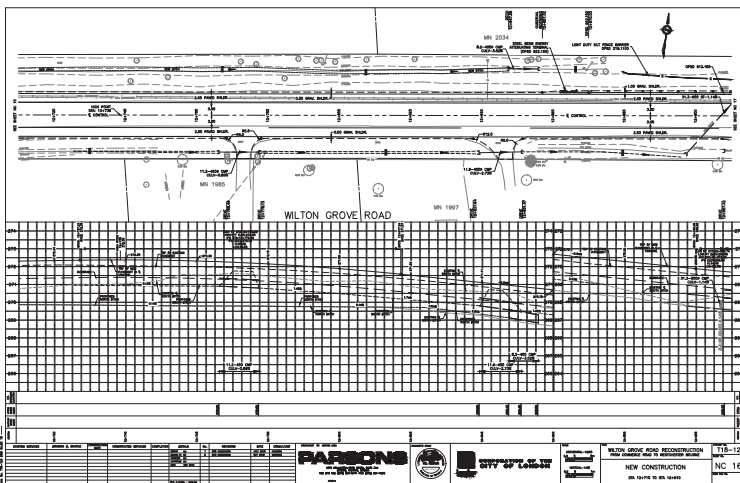
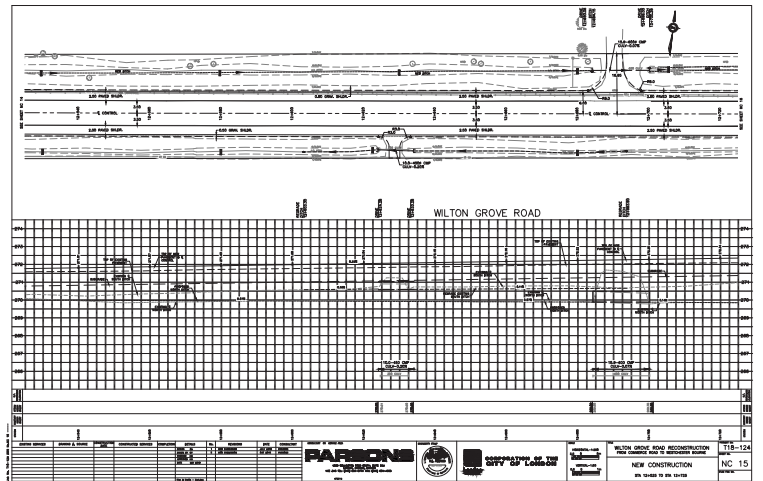
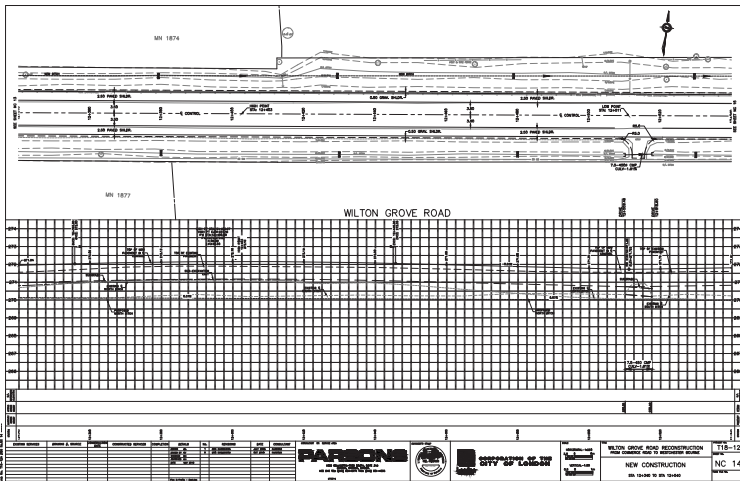
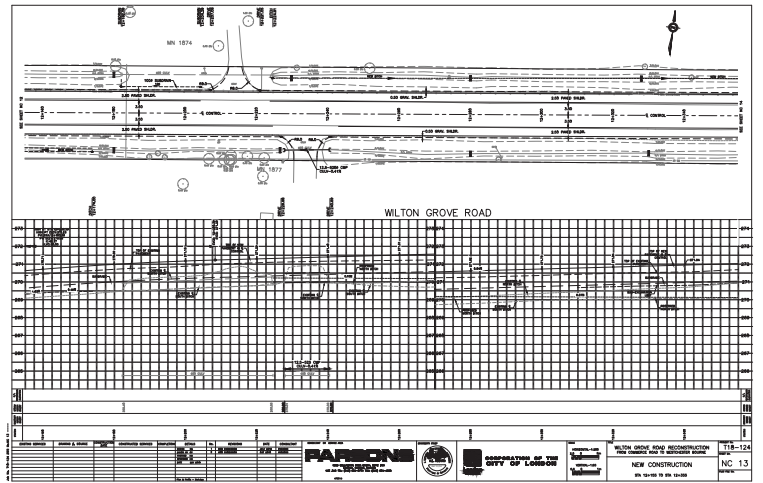
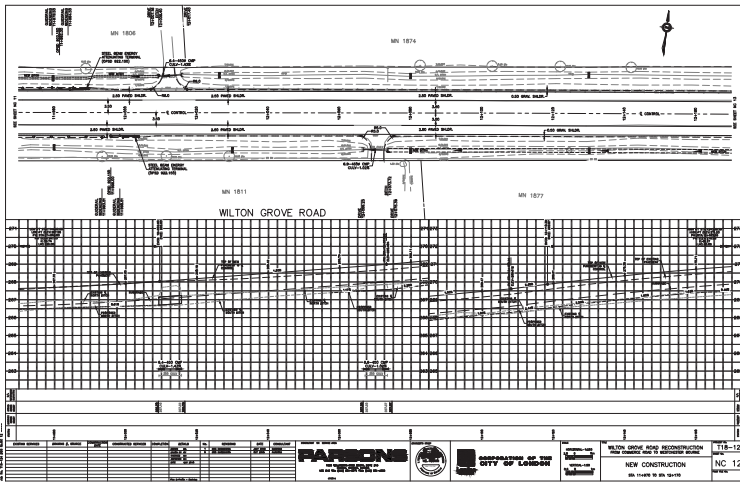

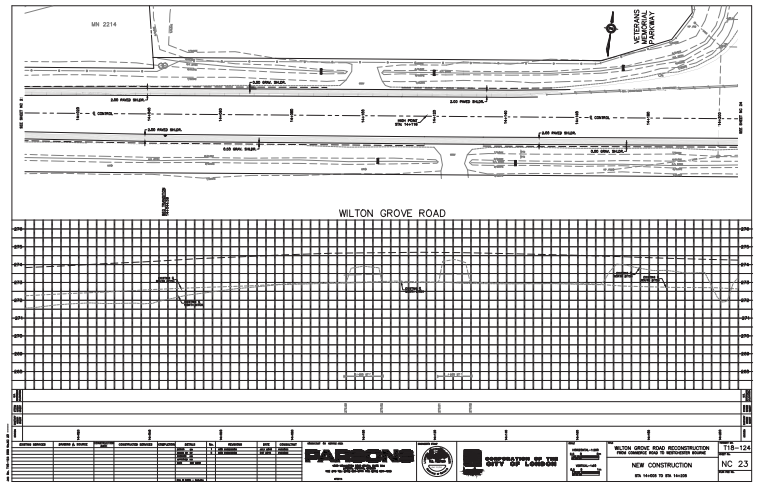
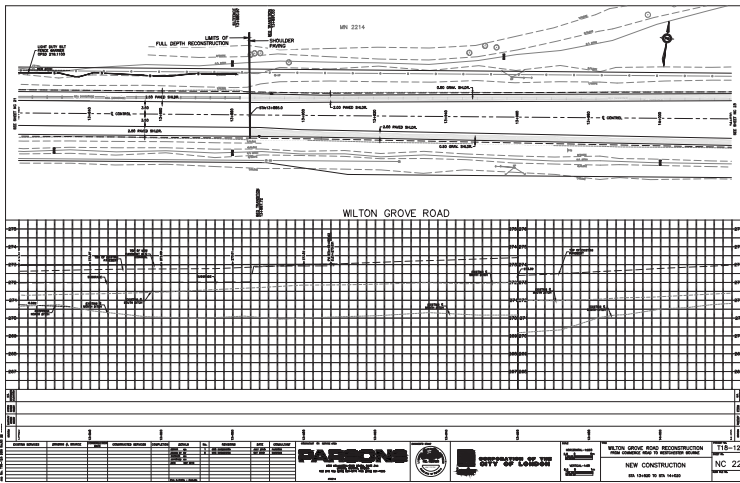
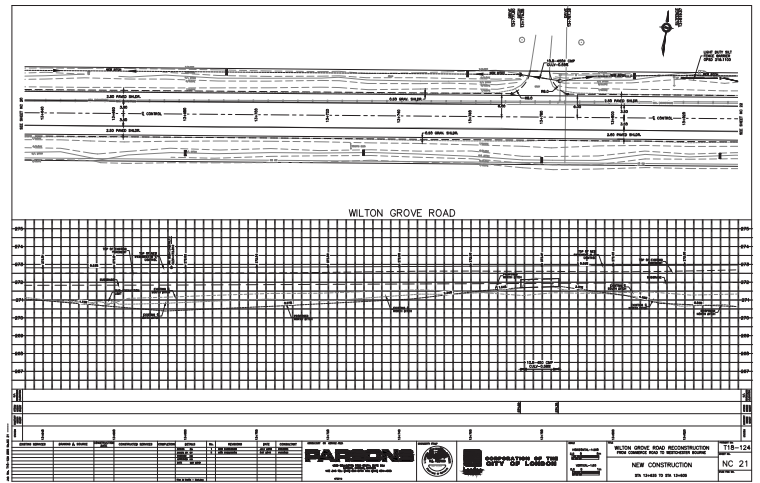
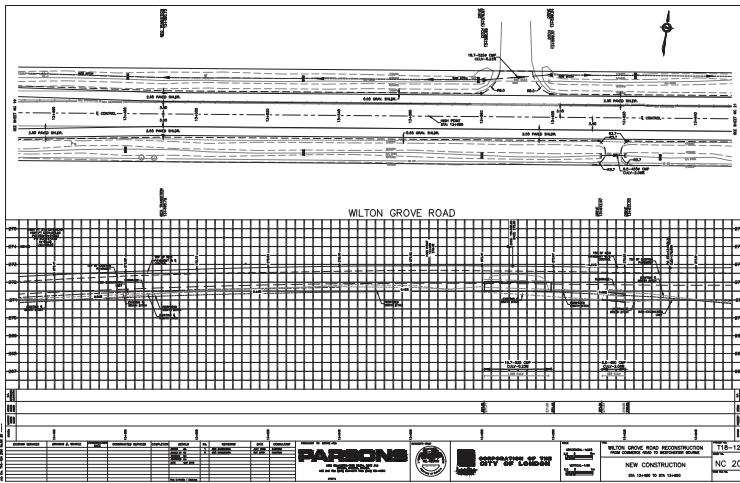
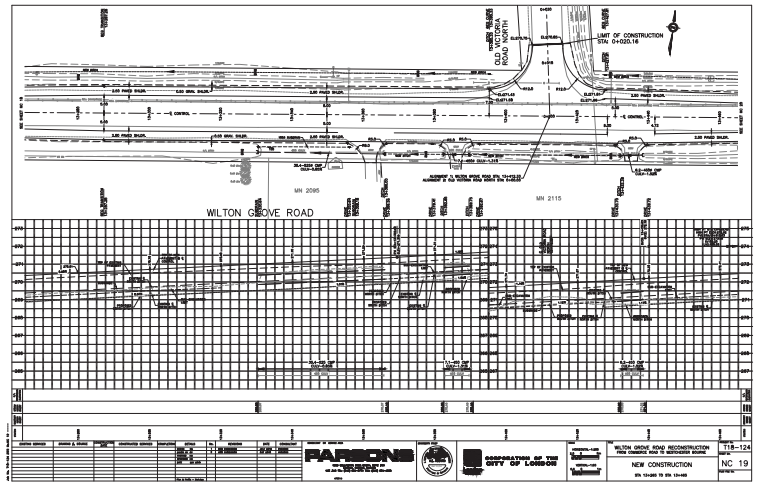
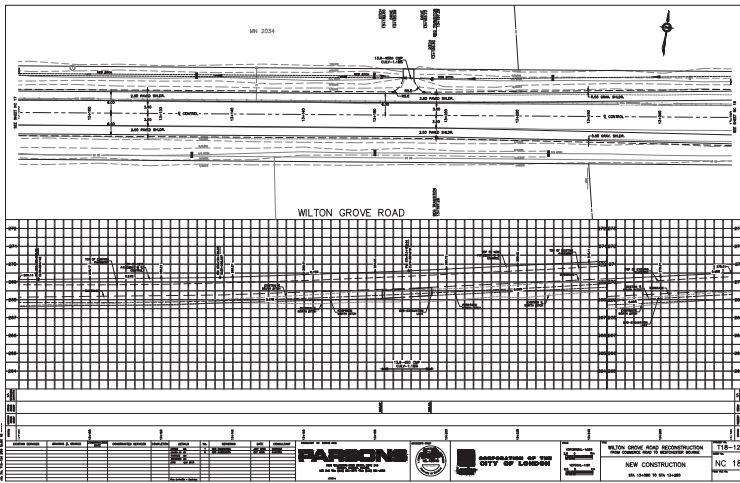

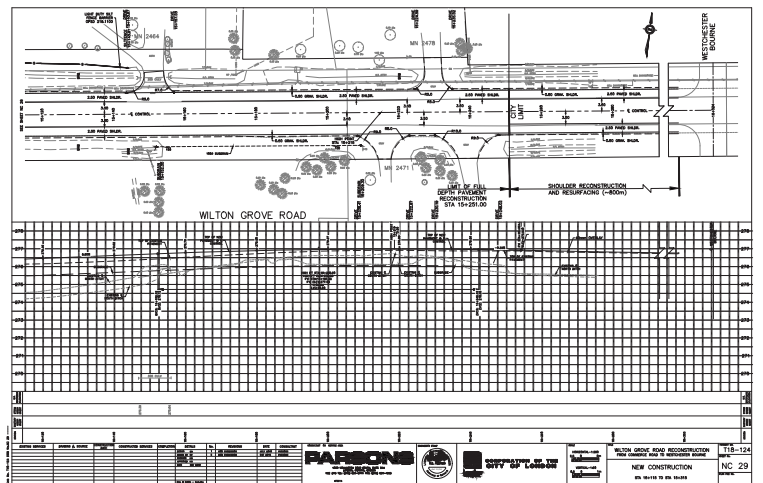
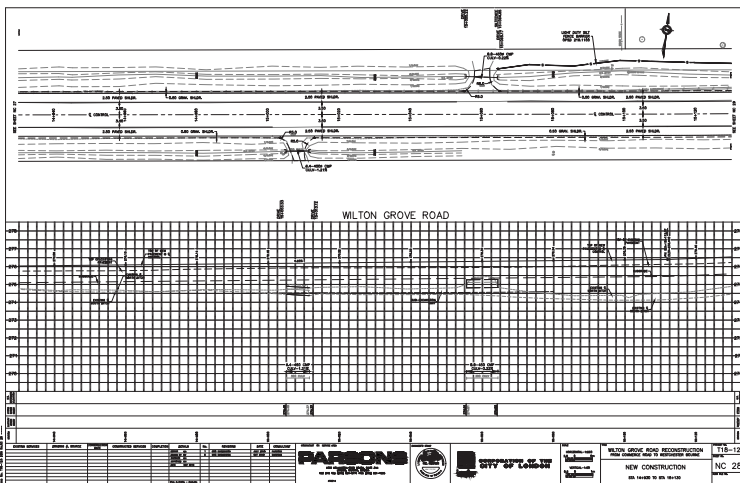
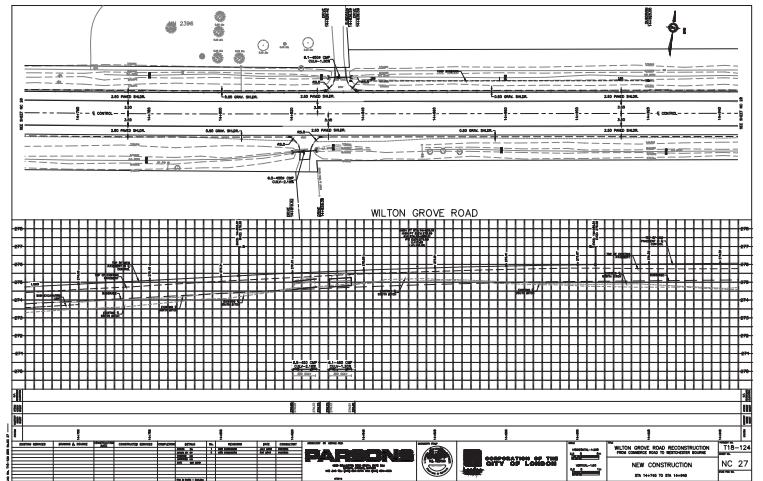
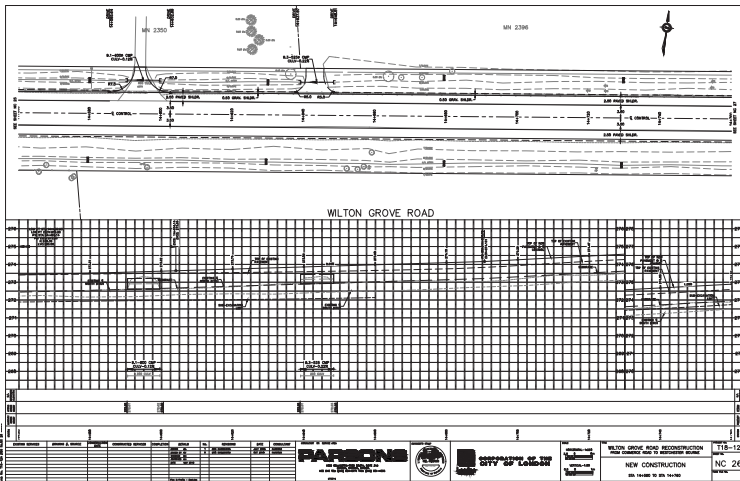
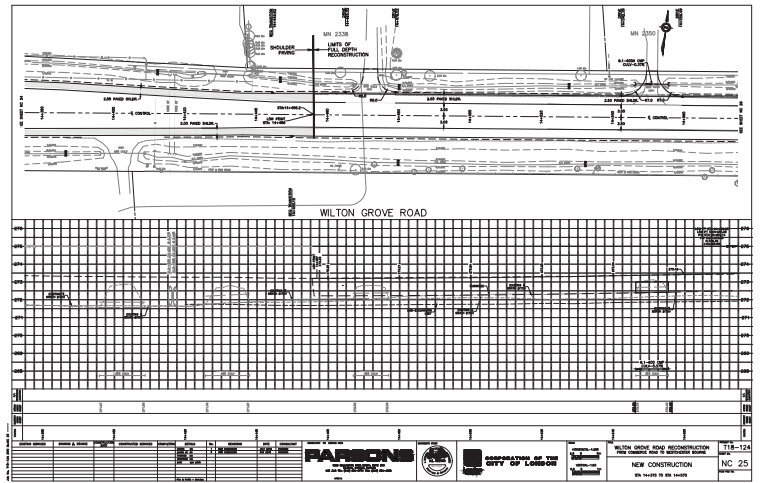
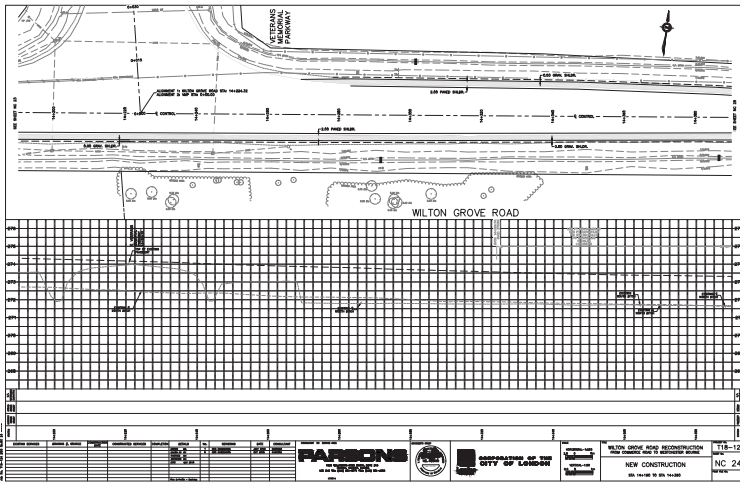

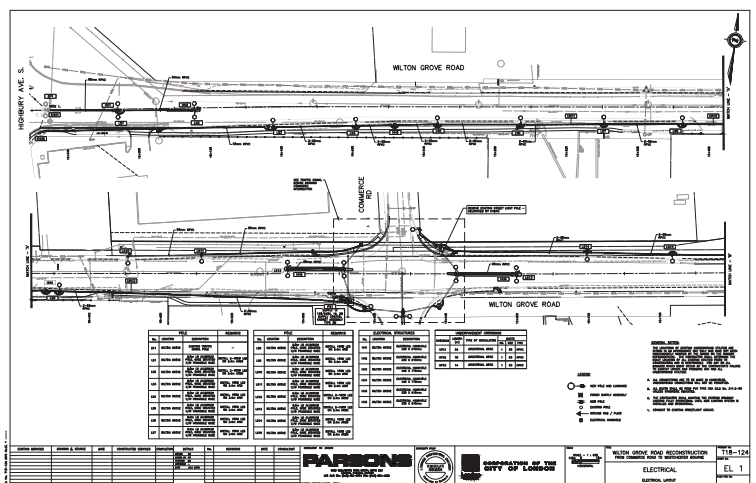
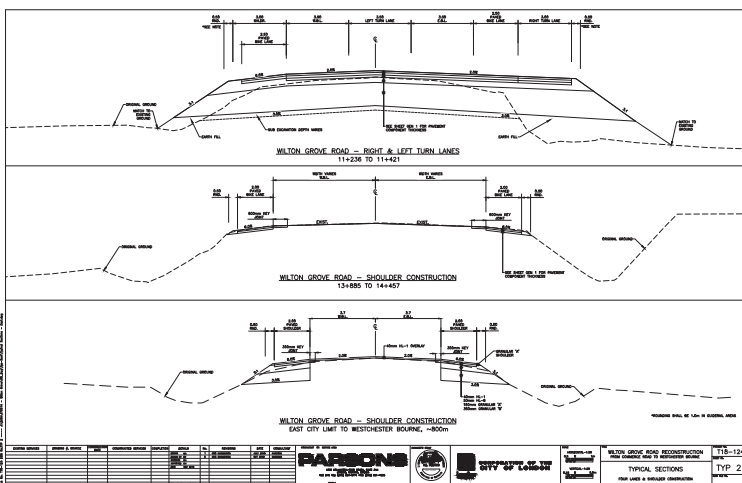
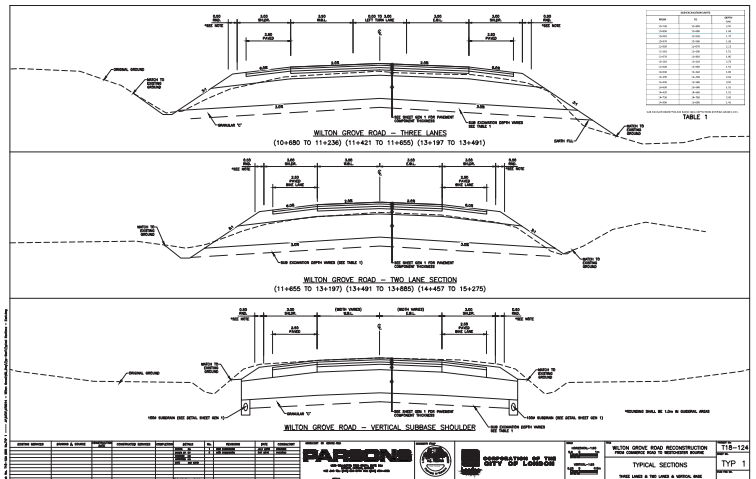
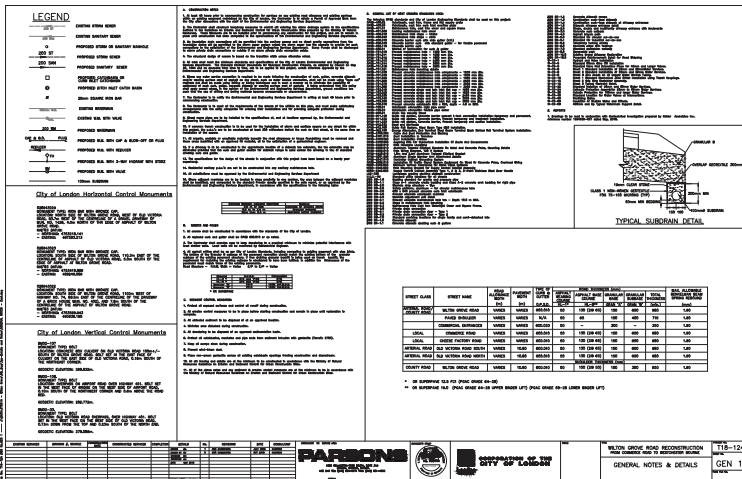
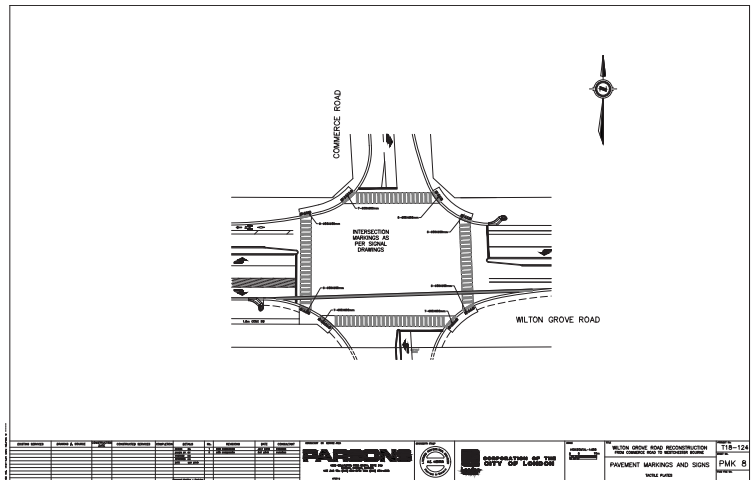
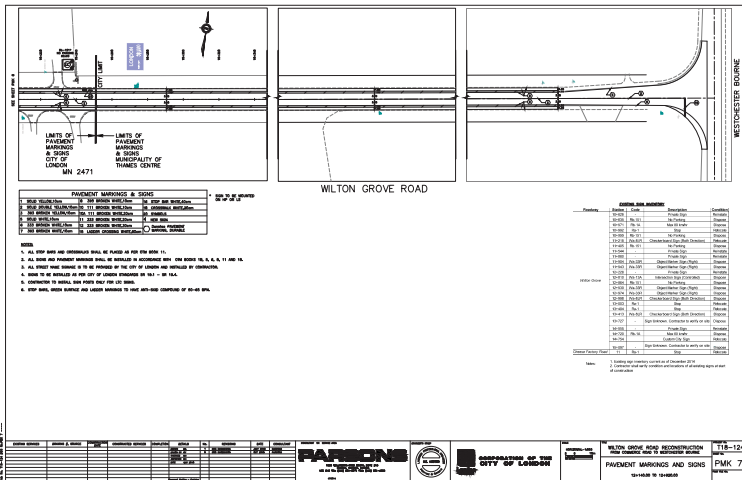

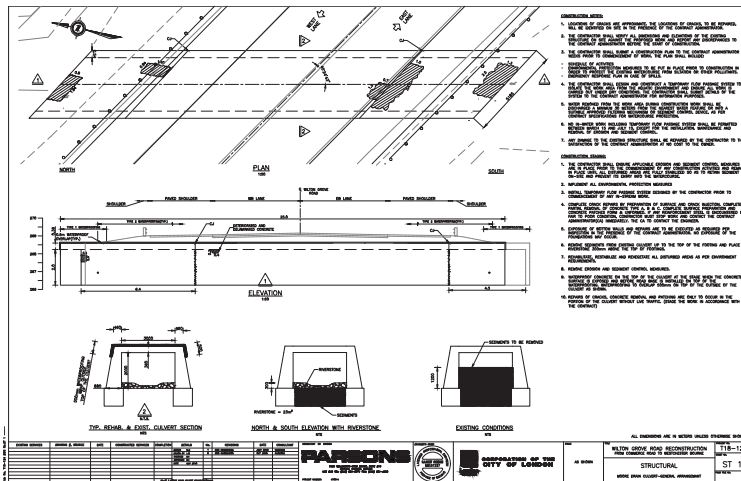
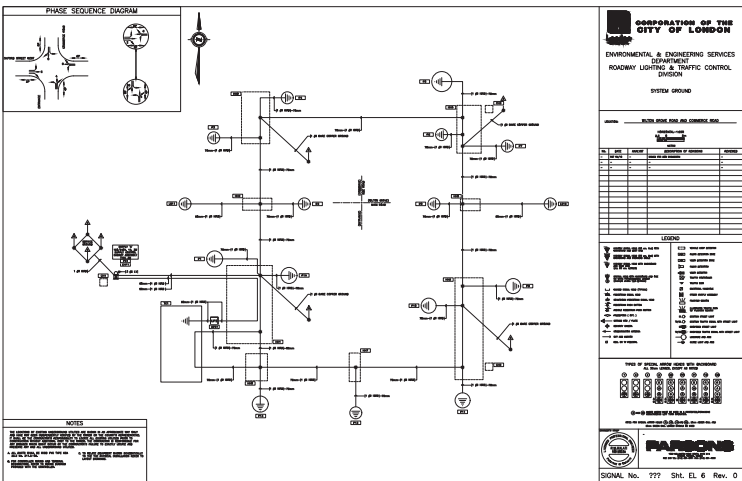
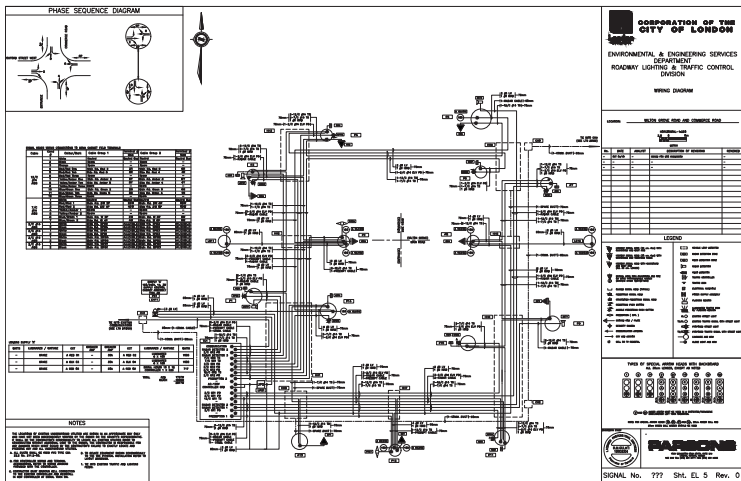
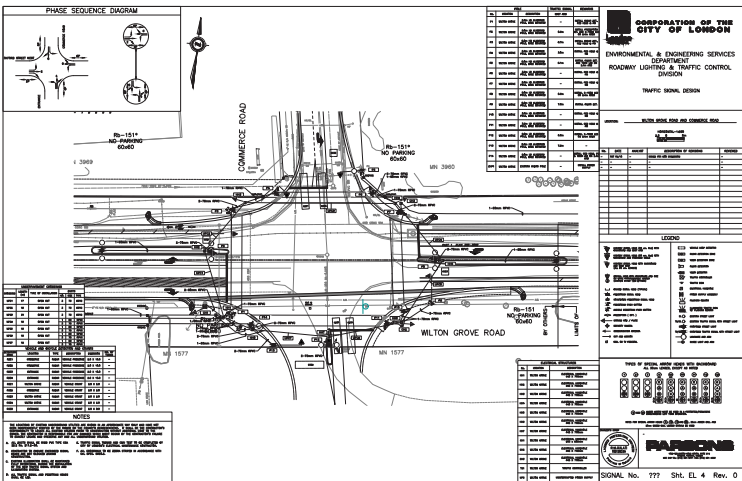
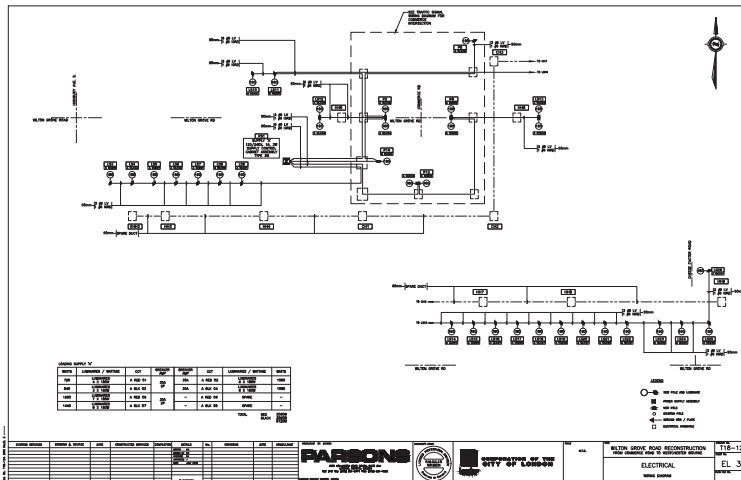
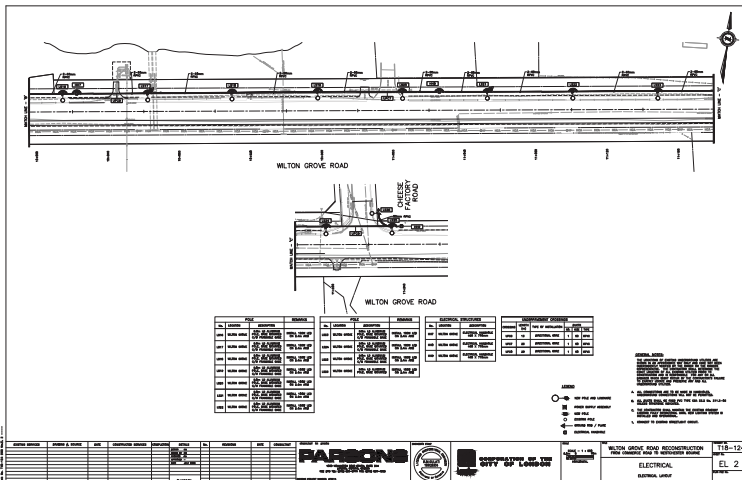

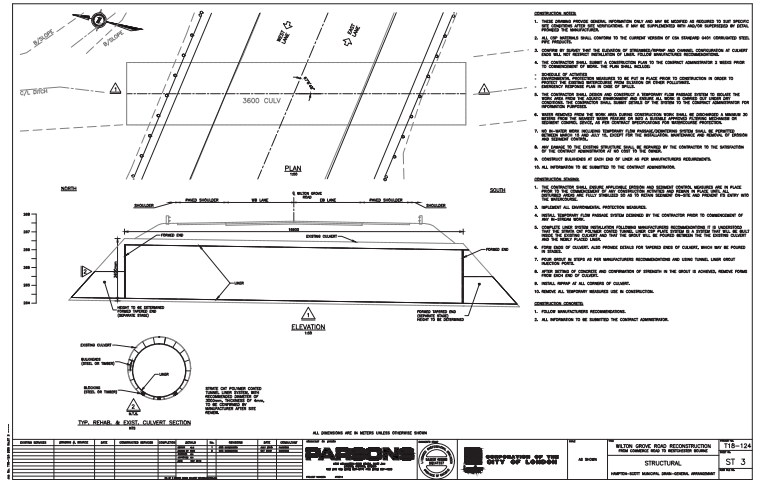
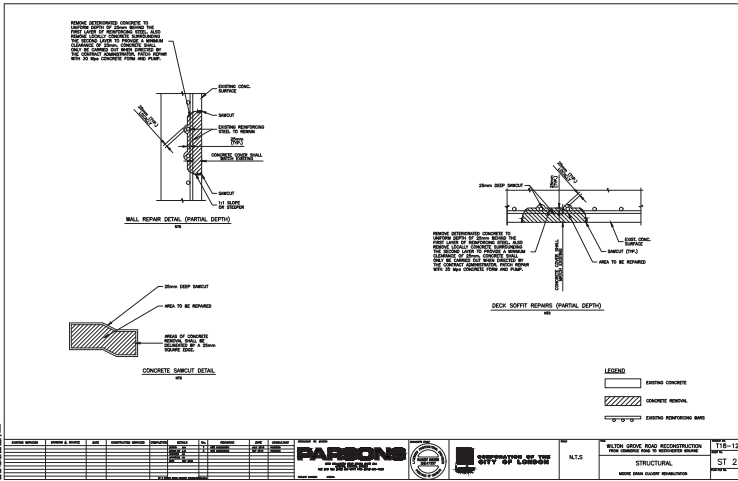

Cycling Advisory Committee

Report

11th Meeting of the Cycling Advisory Committee
November 21, 2018
Committee Room #4

Attendance PRESENT: D. Mitchell (Chair), D. Doroshenkso, R. Henderson, J. Jordan, R. Sirois, D. Szoller, M. Zunti; and P. Shack (Secretary)

ABSENT: W. Pol and A. Stratton

ALSO PRESENT: D. Hall, S. Harding, P. Kavcic, D. MacRae, L. Maitland, B. McCall, A. Miller and S. Wilson

The meeting was called to order at 4:05 PM.

1. Call to Order

1.1 Disclosures of Pecuniary Interest

That it BE NOTED that no pecuniary interests were disclosed.

2. Scheduled Items

2.1 King Street Cycle Lane Improvements Update

That it BE NOTED that the Cycling Advisory Committee heard a verbal update from P. Kavcic, Transportation Design Engineer, with respect to King Street Cycle Lane Improvements Update.

2.2 Old East Village Cycle Track

That Civic Administration BE REQUESTED to consider a review of the presentation with respect to the bi-directional cycle tracks on Dundas Street between William Street and Ontario Street; it being noted that the Cycling Advisory Committee received the ~~attached~~ presentation from R. Henderson and D. Hall, Executive Director, London Cycle Link with respect to the Proposal for Old East Village Cycle Track.

3. Consent

3.1 10th Report of the Cycling Advisory Committee

That it BE NOTED that the 10th Report of the Cycling Advisory Committee from its meeting held on October 17, 2018, was received.

3.2 Municipal Council resolution adopted at its meeting held on October 16, 2018, with respect to 1st Report of the Town and Gown Committee

That it BE NOTED that the Municipal Council resolution adopted at its meeting held on October 16, 2018, with respect to 1st Report of the Town and Gown Committee, was received.

3.3 ReThink Zoning Draft Terms of Reference

That it BE NOTED that the Cycling Advisory Committee held a general discussion with respect to the ReThink Zoning Draft Terms of Reference, and will be bringing forward for comments at a future meeting.

3.4 Notice of Public Update Meeting - Wilton Grove Road Reconstruction - Commerce Road to Westchester Bourne

That it BE NOTED that the Notice of Public Update Meeting-Wilton Grove Road Reconstruction-Commerce Road to Westchester Bourne, was received.

3.5 Notice of Study Completion - Fanshawe Park Road and Richmond Street Intersection Improvements - Municipal Class Environmental Assessment

That it BE NOTED that the Notice of Study Completion-Fanshawe Park Road and Richmond Street Intersection Improvements-Municipal Class Environmental Assessment, was received.

4. Sub-Committees and Working Groups

That it BE NOTED that the Cycling Advisory Committee held a general discussion with respect to bicycle theft in London.

5. Items for Discussion

5.1 Committee Term of Cycling Advisory Committee

That it BE NOTED that the Cycling Advisory Committee heard a verbal update from P. Shack, Committee Secretary, with respect to the extension of the terms of Advisory Committee members; it being noted that the current terms of Advisory Committee members will be extended to the date of June 1, 2019, and a new term will run from June 1, 2019 to February 2021.

5.2 Cycling Advisory Committee Survey - D. Szoller

That it BE NOTED that the Cycling Advisory Committee heard a verbal update from D. Szoller with respect to a Cycling Advisory Committee Survey.

5.3 December Meeting Date

That it BE NOTED that the Cycling Advisory Committee will meet on December 19, 2018.

6. Deferred Matters/Additional Business

None.

7. Adjournment

The meeting adjourned at 6:00 PM.



MEMO

To: City of London Advisory Committees

From: Justin Adema

Department: Planning Services

Date: October 31, 2018

Re: **ReThink Zoning Draft Terms of Reference**

The City is in the beginning stages of a new project called ReThink Zoning, which includes preparing a new Zoning tool that will replace the current Zoning By-law. The new by-law is needed to be consistent with the London Plan and implement its vision and policy direction.

Draft Terms of Reference were prepared and sent to the Planning and Environment Committee on August 13, 2018, following this Council gave direction to circulate the draft Terms of Reference to stakeholders, agencies, and the public for comments.

City Advisory Committees are now asked to review the Draft Terms of Reference before a finalized version is brought to Council for approval. Opportunities will be provided for Advisory Committees to comment throughout the ReThink Zoning process, and these Terms of Reference will frame what that process will include and establishes the goals, objectives, and desired outcomes for the new by-law.

1.0 ReThinking Zoning in London

In 2011, the City of London – including Council, staff, and all of its citizens – began a conversation about the future of our city. It started with a launch event where Peter Mansbridge spoke about the importance of civic engagement in a successful local government, and ended in June, 2016 when City Council adopted the London Plan – a new plan for growth and development in our city.

The London Plan is the culmination of a community conversation, it represents the shared vision, values, and goals for all Londoners. The Plan's key directions are a summary of this vision for the City, and the rest of plan provides a framework to achieve that vision. The next step in the process of planning our city is to examine tools that help us realize the vision we have set.

One important tool to achieving the planning framework articulated in The London Plan is the zoning by-law. London's current zoning by-law is dated, having been prepared following the approval of the 1989 Official Plan to help implement that Plan. With The London Plan we have a new, more strategic approach to City Building that requires a new by-law for its implementation.

ReThink Zoning is a continuation of the original conversation about how Londoners want to see their City grow – only the focus has now shifted from broader policy matters to more technical questions about how we should realize the vision. Instead of asking Londoners what kind of city do you want to live in, we will be working with Londoners to determine how we should get there and how each development across the city should be considered.

1.1 Implementing the London Plan

The London Plan provides a strategic approach to development in London that is based on City Building policies, a City Structure Plan, and a variety of place types. The City Building Policies provide the over-arching direction for how we will grow as a city over the life of the Plan and define the shape, character and form of the City. The City Structure Plan identifies five key foundations that inform the other policies of the Plan: The Growth Framework, The Green Framework, The Mobility Framework, The Economic Framework, and The Community Framework. Each place type is planned to play a unique role within the City Structure and has its own identity and character. The place types work together to create a complete city. All aspects of the place type must contribute to the achieving the Plan's objectives, including the use, intensity, and form of every building and parcel of land.

Zoning is the tool that we currently use to regulate the land use, intensity, and form of development. Therefore, zoning should be viewed as an extension of the Plan and a mechanism to meet its City Building goals. A zoning tool that is linked intrinsically to the policy direction of the London Plan is necessary for the implementation of the Plan.

1.2 Legislated requirements

In addition to requiring our regulatory tools to align with The London Plan, there are also legal issues to consider. The *Planning Act* is the applicable legislation for planning matters in Ontario. It is what requires the City of London to have an Official Plan and permits the City to regulate development as a way of implementing the Plan. The *Act* says that no by-law shall be passed that does not conform with the Official Plan (Section 24(1)). The *Act* also requires that when an Official Plan is updated after a comprehensive review, a municipality shall update the zoning by-law within three years of coming into effect (Section 26(9)). Because The London Plan completely replaces the 1989 Official Plan, it is appropriate to replace the Zoning By-law with a new by-law that conforms to its policies within three years.

2.0 Overarching Goal, Objectives, and Desired Outcomes

This is a major project that will have a lasting impact on how London will be shaped to meet the vision established in The London Plan. This section describes the guiding principles for the project.

2.1 Overarching Goal

To continue the momentum of ReThink London, implement the new London Plan, and foster the growth and development of a great city.

1.2 Objectives

- To create the best implementation tool to fit London's current and future needs
- To implement The London Plan's vision, values, and key directions
- To implement The London Plan place types in terms of use, intensity, and form
- To create a user-friendly and plain language document while recognizing the regulatory nature of the by-law
- To make use of new technologies available for the application and administration of zoning
- To allow for flexible application of the by-law while maintaining a level of certainty and predictability
- To create a tool that allows for efficient planning processes

2.3 Desired Outcomes

- Quality developments across the City that contribute to our city-building goals
- Efficient planning processes that result in great neighbourhoods
- A by-law that can be understood by all users involved in the planning process – including developers, professionals, community groups, and the general public
- A by-law that meets all legislative requirements, is defensible on its planning merits, and includes clear, enforceable regulations.
- A by-law that is intrinsically linked to The London Plan with obvious connections to the use, intensity, and form requirements of the place types as well as the City Building and Our Tools parts of the Plan.

3.0 Work Plan

ReThink Zoning is not just about updating the Zoning By-law Z.-1 to match the London Plan place types. It will consider the full range of possibilities that are available under the *Planning Act* and will look carefully at approaches being taken in other cities to see whether there are opportunities to improve on how we regulate development in our city. The work plan will include time for the research to be completed and analyzed, and needs to be flexible to allow later stages to fit with whatever direction or approach is identified as the best fit in London. To achieve this, a two-phase work plan is proposed. Details are provided for Phase One, however Phase Two will be refined after the details of the types of tools and approaches will be utilized has been confirmed through Phase One. Detailed Terms of Reference for Phase Two are included as a deliverable in Phase One.

3.1 Phase One

Phase One will provide an opportunity to investigate alternate approaches to development regulation and determine what tools should be used to implement the London Plan to achieve its goals.

Tasks to be completed in Phase One include:

- Prepare an RFP and work plan for the completion of Phase One
- Retain a consultant to work collaboratively with staff to complete Phase One
- Complete background research with regards to:
 - Ontario legislated requirements for zoning, including options available to municipalities for the implementation of Official Plans
 - The London Plan policies and directions, in regards to compatibility with different development regulation options available in Ontario

- Best practices from North America and other comparable parts of the world
- Review existing Zoning By-law No. Z.-1 to identify areas of strength or concern, determine what is working and what needs improvement to achieve the overall goals
- Engagement with key stakeholders to assess strengths and weaknesses of our current by-law and the desired outcomes of a new by-law
- Public engagement program to listen to ideas, concerns, and suggestions from Londoners
- Identify key elements/components/areas to be addressed through the new zoning by-law
- Recommend the best zoning approach to implement the policy directions of The London Plan
- Prepare Terms of Reference for Phase 2 – the preparation of the by-law, based on the direction provided by Council

Deliverables to be submitted in Phase One include:

Deliverable	Assignment
● Terms of Reference (Phase 1) – to include Community Engagement Strategy for Phase 1	Prepared by staff
● Request for Proposal (RFP) for consultant to undertake Phase 1	Prepared by staff
● Background Paper – overview of research and engagement findings and linkages to The London Plan	Prepared by consultants
● Recommendation Report – Analysis of issues, recommended tool, draft terms of reference for Phase 2	Prepared by staff, based on recommendations from the consultants
● Terms of Reference (Phase 2) – to include Community Engagement Strategy for Phase 2	Prepared by staff

3.2 Phase Two

Phase Two is when the new by-law will be prepared, based on the approach confirmed through Phase One. The information in this section is general in nature and will be clarified in the detailed Terms of Reference to be prepared in Phase One.

Tasks that will be completed in Phase Two include:

- Prepare a detailed inventory of existing development
 - Review land use
 - Review intensity – may include height, gross floor area, coverage, floor plate area, density in units per hectare, number of bedrooms, parking, floor area ratio
 - Review form – may include site layout (parking, landscaping, orientation, setbacks, and building location on a site), and buildings (massing, step-backs, materials, architecture)
 - Identify and analyze patterns of development to assist in property-appropriate zoning tools
 - Where appropriate, use new technologies to obtain this information (may include LiDAR, remote sensing, or other technologies)
- Analyze and recommend technologies for the administration and presentation of zoning information
 - Explore opportunities of GIS based applications
- Prepare outline of by-law, consideration to be given to:
 - Organization – chapters, types of zones, etc
 - Layout – use of tables, figures, illustrations, document design, etc
- Prepare and test sample zones against existing conditions and potential development opportunities

- Prepare first draft of by-law, provide opportunity for stakeholder and public comments
- Prepare second draft of by-law, circulate for stakeholder and public comments
- Review required amendments to other city by-laws/documents resulting from the replacement of the current zoning by-law
- Prepare final by-law for approval

Deliverables to be prepared in Phase Two include:

- Inventory and analysis of existing development
- Mapping/zoning data overview and recommendation
- First Draft By-law
- Second Draft By-law
- Results of public and stakeholder feedback
- Amendments to other City by-laws and documents
- Final By-law for approval

Note that the deliverables will be prepared by a combination of City staff and consultants. The specific breakdown of responsibilities will be defined through the detailed Phase Two terms of reference.

3.3 Project Scope

The nature of large projects such as ReThink Zoning often includes “scope creep” resulting from the encroachment of additional tasks than was originally planned. It is important to ensure that the scope of this project remains focused in order to achieve the milestones identified in the Project Schedule.

3.4 Project Schedule

Work to be completed	Target completion date
Terms of Reference and RFP for Consultant(s)	Q4, 2018
Retain consultants	Q2, 2019
Background Paper	Q3, 2019
Recommendation Report	Q4, 2019
Terms of Reference – Phase 2	Q4, 2019
Phase 2	TBD – based on TOR

4.0 Project Team

Staff from various departments within the Corporation as well as a consulting team will contribute to the success of ReThink Zoning. This section describes the roles of staff and the consultant to be retained on the project.

4.1 City Staff

This project is part of the Planning Services work plan and will be completed at the direction of the Managing Director, Planning and City Planner. The project lead will be the Manager, Current Planning and the project manager will be a Planner from Planning Services. However, given the scope of this project, significant participation from across all Service Areas of the City of London will be required. Of particular importance will be the contributions of Development & Compliance Services staff, who play a critical role in the implementation of the Zoning By-law. This important role will be reflected in the makeup of the various teams working on the project.

At the outset, three groups of staff will be established to contribute to the completion of this important project. The Project Team will be the main group working on the project on a daily basis, a Steering Committee will be established to provide guidance to the Project Team and contribute at key decision points, and a Technical Resource Group will include staff from virtually every Service Area in the City. This group will review materials and provide input as needed at various points in the process. Some members will play large roles while others will only be required to contribute at certain points.

4.1.1 Project Team

The project team will be responsible to complete the work plan of ReThink Zoning and will be the main contact for consultants retained on this project. The Project Manager will provide leadership to this team by delegating tasks, chairing meetings, and being the main source of information/communication on behalf of the project team. The makeup of the project team will include:

- Manager, Current Planning – Planning Services (Project Lead)
- Planner, Long Range Planning & Research – Planning Services (Project Manager)
- Planner, Current Planning – Planning Services
- Urban Designer – Planning Services
- Manager, Development Planning – Development Services
- Business and Zoning Coordinator, Zoning – Development & Compliance Services

4.1.2 Steering Committee

The Steering Committee will be made up of senior leaders at the City and managers with portfolios that interface with the Zoning By-law. The Role of the Steering Committee will be to provide input, advice, and guidance to the Project Team and will be particularly involved at any key decision point during the project. The Steering Committee will include:

- Managing Director, Planning and City Planner – Planning Services (Steering Committee Chair)
- Managing Director, Development and Compliance Services and Chief Building Official – Development & Compliance Services
- Managing Director, Environmental and Engineering Services and City Engineer
- Director, Development Services – Development & Compliance Services
- Manager, Current Planning – Planning Services
- Manager, Long Range Planning and Research – Planning Services
- Manager, Urban Regeneration – Planning Services
- Manager, Development Services (Site Plan) – Development & Compliance Services
- Manager, Zoning and Public Property Compliance – Development & Compliance Services
- Solicitor II, Legal and Corporate Services

4.1.3 Technical Resource Group

Most internal Service Areas and divisions will contribute at some point during this project. They will not be required to play a major role for all phases of the project but will provide input as needed. Individuals from the divisions/Service Areas listed below will contribute, and other groups may be added depending on the nature of input required.

The Technical Group will comprise staff from Planning Services, Development and Compliance Services, Environmental and Engineering Services, the City Clerk's Office, Corporate Communications, and Neighbourhood, Children and Fire Services.

4.2 Hiring Consultants

Given the scope and complexity of this project, consultants will be retained to support staff in completing the work plan and providing specialized expertise throughout the process. A request for proposals for the Phase One consultant will be prepared and issued following the approval of these terms of reference. Contracts for this project will be divided into the project phases, recognizing that the best zoning approach is identified at the end of Phase One and may require specific knowledge and experience that is beyond the Phase One consulting team.

The selected consultant(s) will have a strong background in planning implementation, and should include experience with various approaches to zoning. The consultant team will need to be able to understand the approach taken through The London Plan and identify ways to achieve its objectives through development regulation. The consultant team will demonstrate the values that guide all planning decisions in London – these are

to be accountable, be collaborative, demonstrate leadership, be inclusive, be innovative, and think sustainably.

It is anticipated that there will be a team of consultants retained as multiple areas of expertise will be required. Some of the specialized areas include:

- Land use planning – ReThink Zoning is a planning review first and foremost. It is required that the lead consultant will include professional planners.
- Urban design – The London Plan integrates urban design into the planning process and approaches to regulation that consider how to ensure an engaging and attractive public realm will be important.
- Mapping/GIS – new and innovative approaches to the mapping components of the zoning by-law are encouraged, and it is expected that the consulting team will bring expertise on this issue.
- Community engagement – public input is important to the success of this project. Effective engagement with the community must be integrated into all parts of the project.
- Application review processes – implementation of the new by-law must work for those who are applying and interpreting the by-law, therefore consideration of this and other administrative matters must be included. The consulting team should have experience and insight into how the new by-law would be “operationalized”.

4.2.1 Expectations and responsibilities

The consulting team will work closely with the Project Manager and Project Team to complete the work plan for this project. Deliverables will be submitted to the Project Team who will coordinate with the Steering Committee and make recommendations, based on the information provided by the consultants, to City Council. The Work Program section of this report identifies what tasks will be led by the consultant team.

5.0 Community Engagement and Information Sharing

This project requires input from a variety of stakeholders, agencies, and the public if it is to be successful. This project will give direction to the way we grow as a city and will shape our neighbourhoods, urban centres, and other places within London. While the intent is not to engage in a discussion about first principles – issues like the city structure and the vision for each place type have been established through The London Plan – there is plenty of opportunity for stakeholders and the public to help shape our approach to how we implement the Plan.

Equally important during this project is the availability of information. People will want to know where this project stands, what opportunities they will have for participation, and how changes to the zoning by-law could affect their properties and communities. Through the various tools available, including the city website, social media, open houses, traditional advertising, and other approaches, we will strive to provide up-to-date and useful information to the public regarding the project.

All members of the public are invited to participate throughout the ReThink Zoning process. Some key stakeholders have been identified and will be invited to meet with staff and discuss the options to replace our zoning by-law. These stakeholders include:

- All City Service Areas
- Advisory Committees to Council
- Public agencies – eg: London Economic Development Corporation, Upper Thames River Conservation Authority, London Hydro, London Housing Development Corporation, Ministry of Municipal Affairs.
- Community organizations – eg: business improvement areas, the Urban league of London, neighbourhood associations, ratepayer groups.
- The Development Industry – eg: London Development Institute, London Home Builders Association, London Association of Planning Consultants, and other members of the Building and Development Liaison Forum.

Your feedback is important and will be treated as confidential.

Please return by xxxxx to compile responses. Thanks.

1. Were you able to:

- | | | |
|--|---|---|
| * Attend meetings consistently to comply with attendance criteria | Y | N |
| * Contribute to working groups, policy and issues, recommendations | Y | N |
| * Make a motion and understand the process to follow it through | Y | N |

If yes, what motivated you? -

If no, what hindered you?

2. Overall, is CAC running ok? Y N

- | | | |
|---|---|---|
| * Agendas are relevant to CAC's mandate | Y | N |
| * Meetings start on time and are not longer than they need to be | Y | N |
| * You are always given opportunity to contribute to discussion issues | Y | N |
| * Other members seem prepared for meetings and able to contribute | Y | N |
| * The committee works well as a team when resolution is needed | Y | N |

3. CAC is effective? Y N

- | | | |
|---|---|---|
| * Our mandate is sufficient to protect the local environment/ecology | Y | N |
| * We were effective in fulfilling our mandate over the last term | Y | N |
| * Our recommendations are taken seriously and are acted upon | Y | N |
| * We are kept informed on issues that pertain to our mandate | Y | N |
| * Most members make a regular contribution to the tasks of CAC | Y | N |
| * Our membership contains the skill sets required to execute our duties | Y | N |
| * I think CAC has sufficient visibility with members of the public | Y | N |

* CAC has good support from staff members that support the committee Y N

4. What can CAC do differently?

* What aspect of CAC is the most rewarding for you?

* What aspect is the biggest turn-off for you?

* What would you say CAC's strength is?

* What would you say CAC's weakness is?

* What would you like CAC to have accomplished that we/you didn't?

* What keeps CAC from being as effective as it could be?

* To improve CAC we should introduce:

* Before I joined CAC, I wish someone had told me

* Other comments: